

WBPDC

THE WEST BENGAL POWER DEVELOPMENT CORPORATION LIMITED

(A Government of West Bengal Enterprise)

NOTICE INVITING TENDER (NIT)

e-Procurement

NIT No: WBPDC/CORP/NIT/E1317/19-20 Dtd:-12/03/2020

National Competitive Bidding

For

Design & Engineering, Manufacture / Procurement, Supply, Erection, Testing and Commissioning of 10MW Phase-II Grid Connected Floating Solar Photovoltaic Power Plant on Raw Water Pond No.1, 2 & 4 in Sagardighi Thermal Power Project(SgTPP), Murshidabad, West Bengal including warrantee obligation with 05 (Five) years comprehensive Operation and Maintenance.

The West Bengal Power development Corporation Limited

(A Government of West Bengal Enterprise)

Bidyut Unnauan Bhaban, Plot No. 3/C LA-Block, Sector-III, Bidhannagar,
Kolkata-700 106

March-2020

These documents are meant for the exclusive purpose of bidding against this NIT and shall not be transferred, reproduced or otherwise used for purposes other than that for which they are specifically issued

CONTENTS

SECTION-I	11
INSTRUCTION TO THE BIDDER (ITB)	11
A. SCOPE & QUALIFICATION	11
1.1 NAME OF THE WORK.....	11
1.2 SOURCE OF FUND	11
1.3 SCOPE OF WORK:	11
1.4 QUALIFYING REQUIREMENT FOR BIDDERS:.....	14
1.5 RESPONSIBILITY OF BIDDERS	18
1.6 COST OF BIDDING	19
B. THE BIDDING DOCUMENTS	19
1.7 CONTENTS OF BIDDING DOCUMENTS	19
1.8 SITE VISIT	20
1.9 CLARIFICATIONS ON BIDDING DOCUMENTS	21
1.10 PRE-BID MEETING	21
1.11 AMENDMENT OF BIDDING DOCUMENTS	22
C. PREPARATION OF BIDS	22
1.12 DOCUMENT CONSTITUTE THE BID	22
1.13 DEVIATION	23
1.14 GENERAL GUIDANCE FOR E- TENDER.....	23
1.15 BID PRICES.....	24
1.16 PERIOD OF VALIDITY OF BIDS	26
1.17 BID SECURITY.....	26
1.18 SIGNING OF BIDS.....	27
D. SUBMISSION OF BID	27
1.19 SUBMISSION OF BID	27
1.20 DEADLINE FOR SUBMISSION OF BIDS	31
1.21 WITHDRAWAL OF BIDS	32
E. OPENING AND EVALUATION OF TENDER	32
1.22 BID OPENING	32
1.23 PROCESS TO BE CONFIDENTIAL	33
1.24 CLARIFICATION OF BIDS	33
1.25 DETERMINATION OF RESPONSIVENESS	33
1.26 CORRECTION OF ARITHMETICAL ERRORS IN PRICE BID	34
1.27 TIME SCHEDULE.....	35
1.28 PROCEDURE OF EVALUATION OF BIDS	35

1.29	COMPARISON OF BIDS.....	35
F.	AWARD OF CONTRACT.....	36
1.30	AWARD CRITERIA.....	36
1.31	RIGHT TO REJECT BIDS	36
1.32	LETTER OF AWARD.....	36
1.33	SIGNING OF CONTRACT AGREEMENT	37
1.34	CONTRACT PERFORMANCE GUARANTEE	37
1.35	MISREPRESENTATION BY THE BIDDER	38
1.36	CORRUPT OR FRAUDULENT PRACTICES.....	38
	SECTION-II	40
	BID DATA SHEET	40
2.1	A. SCOPE & QUALIFICATION	40
2.2	B. THE BIDDING DOCUMENTS	40
2.3	C. PREPARATION OF BIDS.....	41
2.4	D. SUBMISSION OF BIDS.....	41
	SECTION-III.....	43
	GENERAL CONDITION OF CONTRACT (GCC).....	43
A.	CONTRACT AND INTERPRETATION	43
3.1.	DEFINITION OF TERMS	43
3.2.	CONTRACT DOCUMENTS.....	48
3.3.	NOTICE.....	49
3.4.	INTERPRETATION	50
3.5.	GOVERNING LAW	51
3.6.	DISPUTE RESOLUTION.....	52
3.7.	COMPLIANCE WITH LAWS	53
B.	SUBJECT MATTER OF CONTRACT	53
3.8.	SCOPE OF WORKS	53
3.9.	VARIATION, ADDITIONS AND OMISSIONS	59
3.10.	OBLIGATIONS OF THE CONTRACTOR.....	59
3.11.	OBLIGATIONS OF THE PURCHASER	60
C.	PAYMENT	61
3.12.	CONTRACT PRICE	61
3.13.	TERMS AND PROCEDURE FOR PAYMENT.....	61
3.14.	SECURITIES	61
3.15.	TAXES, DUTIES, LABOUR CESS AND OTHER LEVIES	62
D.	INTELLECTUAL PROPERTY	65
3.16.	PATENT RIGHTS & ROYALTIES.....	65
3.17.	CONFIDENTIAL INFORMATION.....	67
3.18.	ADVERTISING	67

E.	WORK EXECUTION	68
3.19.	PURCHASER'S REPRESENTATIVE.....	68
3.20.	CONTRACTOR'S REPRESENTATIVE.....	68
3.21.	MILESTONE OF PROJECT	70
3.22.	SUBMISSION OF DETAILED DESIGN REPORT.....	71
3.23.	PROGRAMME.....	71
3.24.	DESIGN AND ENGINEERING	73
3.25.	PROCUREMENT.....	75
3.26.	CONTRACTOR'S CONSTRUCTION MANAGEMENT:.....	76
3.27.	INSPECTION & TESTING	79
3.28.	TESTS ON COMPLETION.....	82
3.29.	REJECTION	83
3.30.	PERMISSION TO DELIVER.....	83
3.31.	COMPLETION OF WORKS	84
3.32.	TAKING OVER.....	85
F.	GUARANTEES AND LIABILITIES	86
3.33.	NET MINIMUM GUARANTEED GENERATION (NMGG)	87
3.34.	LIQUIDATED DAMAGES (LD).....	87
3.35.	DEFECTS LIABILITY.....	88
3.36.	LIMITATIONS OF LIABILITY	91
G.	RISK DISTRIBUTION	92
3.37.	TRANSFER OF PURCHASERSHIP	92
3.38.	RISK AND RESPONSIBILITY	93
3.39.	CARE OF WORKS	93
3.40.	ACCIDENT OF INJURY	94
3.41.	INSURANCE	95
3.42.	CHANGE IN LAWS AND REGULATIONS.....	96
3.43.	FORCE MAJEURE	97
3.44.	WAR RISKS.....	98
H.	CHANGE IN CONTRACT ELEMENTS	98
3.45.	VARIATIONS	98
3.46.	EXTENSION OF TIME FOR COMPLETION	101
3.47.	TERMINATION.....	102
3.48.	ASSIGNMENT & SUB-CONTRACTING	107
3.49.	JOINT AND SEVERAL LIABILITY	107
	SECTION -IV	109
	SPECIAL CONDITION OF CONTRACT (SCC)	109
4.1	DEFINITION	109
4.2	CONTRACT PERFORMANCE GUARANTEE	110
4.3	PAYMENTS.....	110
4.4	ESCALATION	118

4.5	LIQUIDATED DAMAGES	118
4.6	NOTICES	118
4.7	LABOUR	119
4.8	SAFETY MEASURES	121
4.9	FIRE FIGHTING MEASURES	121
4.10	DEPLOYMENT OF MANPOWER	121
4.11	QUANTITY OF WORK.....	122
4.12	PROJECT MANAGEMENT	122
4.13	ACCIDENT OR INJURY TO WORKMEN.....	123
4.14	REGULATIONS & STANDARDS.....	123
4.15	INSPECTION AND TESTING	123
4.16	DESIGN AND ENGINEERING	123
4.17	COMPLETION OF WORK.....	124
4.18	TRAINING OF OWNER’S ENGINEER	124
4.19	TAKING OVER	124
4.20	COMPREHENSIVE MAINTENANCE	125
4.21	WARRANTY OF EQUIPMENT	126
4.22	MANUFACTURER WARRANTY CERTIFICATE:.....	126
4.23	PERFORMANCE GUARANTEE OF PV MODULE:	127
4.24	KICK OFF MEETING	127
SECTION -V.....		129
TECHNICAL SPECIFICATION		129
A.	GENERAL REQUIREMENTS:.....	129
5.1	NAME OF THE WORK:	129
5.2	SCOPE OF THE WORK:.....	129
5.3	PROJECT SCHEDULE:.....	129
5.4	MODE OF EXECUTION	129
5.5	SITE INSPECTION	130
5.6	FACILITIES AT SITE.....	130
B.	SYSTEM DESCRIPTION:.....	130
5.7	LAYOUT:.....	130
C.	TECHNICAL SPECIFICATION (CIVIL)	134
5.8	TECHNICAL SPECIFICATION FOR CIVIL JOB	134
5.8.1	MODULE MOUNTING STRUCTURE	134
5.8.2	INVERTER CUM CONTROL BUILDING:.....	139
5.8.3	PV ARRAY O&M MAINTENANCE ARRANGEMENT.....	140
5.8.4	APPROCH ROAD FOR SOLAR POWER PLANT.....	140
5.8.5	WATCHMEN / SECURITY CABIN	140
5.8.6	TRANSFORMER YARD	141
D.	TECHNICAL SPECIFICATION FOR ELECTRICAL.....	141
5.9	SPECIFICATIONS FOR SUPPLY MATERIAL.....	141

5.9.1	PV MODULE:	141
5.9.2	GRID CONNECTED INVERTERS.....	151
5.9.3	PV ARRAY.....	158
5.9.4	STRING MONITORING BOX (SMB)	158
5.9.5	THREE WINDING TRANSFORMER.....	160
5.9.6	33kV INDOOR SWITCHGEAR & POWER EVACUATION	166
5.9.7	33kV OUTDOOR SWITCHYARD:.....	181
5.9.8	STATION AUXILIARY TRANSFORMER	183
5.9.9	LT SWITCHGEAR	186
5.9.10	DC BATTERY, BATTERY CHARGING EQUIPMENT & DCDB	192
5.9.11	RELAYS (For HT and LT Switchgear)	199
5.9.12	PROTECTION SYSTEM.....	203
5.9.13	EARTHING AND LIGHTNING PROTECTION SYSTEM	206
5.9.14	CONTROL, MONITORING AND DATA ACUSITION.....	210
5.9.15	CABLES & CONDUCTOR:.....	224
5.9.16	DATA LOGGER:.....	232
5.9.17	WEATHER MONITORING STATION	233
5.9.18	WEB BASED ON LINE REMOTE MONITORING SYSTEM:.....	233
5.9.19	EXPORT IMPORT ENERGY METER:.....	234
5.9.20	ILLUMINATION SYSTEM	235
C.	MISCELLANEOUS WORKS:	237
5.9.21	FIRE PROTECTION SYSTEM	237
5.9.22	VENTILATION SYSTEM	238
5.9.23	AIR CONDITIONING SYSTEM.....	239
5.9.24	DRINKING WATER	240
5.9.25	SIGNAGE:.....	240
5.9.26	FIRE BUCKETS AND HOLDING STANDS	241
5.9.27	KIOSK	241
5.9.28	TOOLS, TACKLES AND SPARES	242
5.9.29	OTHER CONDITIONS	242
5.9.30	SPECIFICATION OF 36kV OUT DOOR VCB	242
D.	APPROVED VENDOR LIST FOR BOIs:	252
SECTION – VI	255
FORM-1:	CHECK LIST: FORM	257
FORM-2:	FORWARDING LETTER FOR BID SECURITY AND TENDER FEE.....	259
FORM-3:	BID FORM/UNDERTAKING	260
FORM-4:	BID SECURITY	263
FORM-5:	SUMMARY STATEMENT OF YEARLY TURNOVER AND NET WORTH.....	264
FORM-6:	CAPABILITY STATUS.....	265
FORM-7:	SIMILAR TYPE OF ORDERS.....	266
FORM-8:	CURRICULUM VITAE OF KEY PERSONNEL	267

FORM-9: FORMAT FOR SUBMISSION OF PRE-BID QUERIES	268
FORM-10: PROPOSED MODIFICATIONS	269
FORM-11: PROFORMA FOR JOINT VENTURE/CONSORTIUM AGREEMENT	270
FORM-12: POWER OF ATTORNEY.....	274
FORM-13: DECLARATION FOR NET MINIMUM GUARANTEED GENERATION	276
SECTION – VII	277
ANNEXURES	277
ANNEXURE-1: CONTRACT AGREEMENT.....	279
ANNEXURE-2: BG (CONTRACT PERFORMANCE)	281
ANNEXURE-3: BG (MOBILISATION ADVANCE).....	283
ANNEXURE-4: FOR EXTENSION BG	284
ANNEXURE-5: INDEMNITY BOND	285
ANNEXURE-6: COMPLETION CERTIFICATE	287
ANNEXURE-7: APPLICATION FOR PAYMENT.....	288
ANNEXURE-8: TAKING OVER CERTIFICATE	289
ANNEXURE-9: NO-CLAIM CERTIFICATE	290
ANNEXURE-10A: INDEMNITY FOR EQUIPMENT.....	291
ANNEXURE-10B: APPLICATION FOR MATERIAL GATE PASS	294
ANNEXURE-11: AUTHORISATION LETTER	295
ANNEXURE-12: MATERIAL RECEIPT CERTIFICATE.....	296
BOQ for Price Schedule.....	297
TENDER LAYOUT DRAWING.....	298

BID INFORMATION SHEET

S1	Aspect	:	Description of Aspect
1.	Title of the NIT	:	Design & Engineering, Manufacture / Procurement, Supply, Installation, Testing and Commissioning of 10 MW Phase-II Grid connected Floating Solar Photovoltaic Power Plants on Raw Water Pond No.1, 2, & 4 in Sagardighi Thermal Power Project (SgTPP), Murshidabad, West Bengal, India in turnkey basis including warrantee obligation with 05 (Five) years comprehensive Operation and Maintenance.
2.	NIT NO. & Date	:	WBPDC/CORP/NIT/E1317/19-20 Dtd:-12/03/2020
3.	Document Download start date		13/03/2020 from 11:00 Hrs
4.	Pre-bid queries submission end date		25/03/2020 up to 15:00 Hrs.
5.	Pre-Bid Meeting		27/03/2020 at 15:00 Hrs
6.	Bid submission start date		01/04/2020 at 11:00 Hrs
7.	Bid submission end date		15/04/2020 at 15:00 Hrs
8.	Tender cost and Earnest Money physical submission at Corporate office		15/04/2020 to 17/04/2020 from 11:00 Hrs to 15:00 Hrs
9.	Technical Bid opening date		17/04/2020 at 15:30 Hrs
10.	Uploading of Technical Bid Evaluation sheet		To be notified through system generated message
11.	Financial Bid opening date		To be notified through system generated message
12.	Uploading of Financial Bid evaluation sheet		To be notified through system generated message
13.	Scope of Work	:	Clause No.ITB1.3
14.	Estimated Cost	:	Rs.60.02Cr including GST (Rupees Sixty Crore and

S1	Aspect	:	Description of Aspect
			Two lakh only).
15.	Cost of the Tender	:	Rs. 5900.00 (Rs. Five Thousand only)
16.	Bid Security/ EMD	:	Rs. 120 Lakh (Rupees One Crore Twenty Lakh) as per clause ITB1.17 of Section-I.
17.	Name, Designation, Address and other details	:	The General Manager(M&C) , The West Bengal Power Development Corp. Ltd. Bidyut Unnayan Bhaban, Plot No. 3/C LA-Block, Sector-III, Bidhannagar,Kolkata-700 106
18.	For any Bid quarry contact Person		Mr. S Sengupta, DGM(M&C), Telephone: 0091 – 033 2339 3498, Email: s.sengupta@wbpdcl.co.in
19.	Date of Commencement	:	From the date of issuance of Letter Of Award (LOA).
20.	Time for Completion	:	Clause No.3.21
21.	Possession of Site	:	Immediately on receipt of LOA from Purchaser (WBPDCL).
22.	Performance guarantee for execution of contract	:	i. 10% of the LOA values in the form of bank guarantee valid for a period of Seventy Two (72) months with further claim period for ninety (90) days thereafter and as per clause from 3.14.2 & 4.2 of general instructions from nationalized bank as per WBPDCL approved format. ii. Should be submitted within 15 days from the date of LOA.(BG Format Annexure-2)
23.	Defects Liability Period	:	Sixty (60) calendar months from the date of issue of final completion certificate /Acceptance of work by WBPDCL (ANNEXURE-6).
24.	Security Deposit (SD)	:	5% of the bill value shall be deducted from every bill. SD will be released with the final.
25.	Minimum value of work for each RA Bill	:	Rs.10.00 Lakhs.(Rupees Ten lakhs only)
26.	Performance Warranty	:	10% of the Contract value will be retained by the Purchaser for the performance warranty and the same will be paid in 2% yearly after successful

Sl	Aspect	:	Description of Aspect
			completion of the work i.e. up to defect liability period.
27.	Integrated project performance of Net Minimum Guaranteed Generation (NMGG)	:	Integrated project performance of minimum solar energy generation at the rate of 1.52MU annually per MWp with degradation of 1% for any reason, from second year onwards.
28.	Liquidated damages for Delay (LD Clause)	:	<p>a. Time Delay: 0.5 % of Contract value for per week delay or part there of subject to a maximum of 10% of the contract value.</p> <p>b. Milestone Delay: Delay in attaining the milestones by the contractor shall lead to imposition of intermediary Liquidated damages @0.25% per week of delay upto the maximum extent of 5(Five) Percent of the Contract price.</p>
29.	Performance Penalty	:	Integrated project performance of minimum solar energy at a rate of 1.52MU annually per MWp with degradation of 1% for any reason. If generated units fall short, then Rs.6.50 per unit of short fall will be deducted from performance warranty every year up to 5 th year.
30.	Statutory Taxes	:	All the prices are to be quoted exclusive of taxes and duties. All taxes and duties are to be separately disclosed as line items to arrive at the final cost. Tender evaluation will be made on the basis of final cost. Tax and duties will be paid at actual by Purchaser.
31.	Operation and Maintenance Cost (Including all Consumables)	:	10% of the Project cost (excluding Taxes and Duties) for 5(five) years. Clause No. GCC 3.8.4
32.	Insurance	:	Insurance of work and workmen including third party insurance are applicable and to be borne by the Contractor until final handover of the project.

SECTION-I

INSTRUCTION TO THE BIDDER (ITB)

A. SCOPE & QUALIFICATION

1.1 NAME OF THE WORK

Design & Engineering, Manufacture / Procurement, Supply, Installation, Testing and Commissioning of 10 MW Phase-II Grid connected Floating Solar Photovoltaic Power Plants on Raw Water Pond No.1, 2 & 4 in Sagardighi Thermal Power Project(SgTPP), Murshidabad, West Bengal, India in turnkey basis including warrantee obligation with 05 (Five) years comprehensive Operation and Maintenance.

1.2 SOURCE OF FUND

The West Bengal Power Development Corporation Ltd (hereinafter referred to as **WBPDCCL** or "**Purchaser**") intends to finance the Work covered under these Bidding Documents from the Source as mentioned in the Bid Data Sheet (BDS).

1.3 SCOPE OF WORK:

The brief scope of work covered under this Tender shall be included but not limited to the following:-

- 1.3.1. The scope of work shall be on the basis of single source responsibility, completely covering all the Equipment/Material specified under the **Technical Specifications**. The work is to be executed on turnkey basis. The Purchaser will not supply any material departmentally. It shall include the following:
 - a. Detailed Site Survey of the Power Plant Raw Water Pond area of WBPDCCL for Designing and Engineering.
 - b. Submission of Detailed Design Report indicating technical suitability of site for installation of the Power Plant with layout plan.
 - c. Detailed Design of the Equipment/ Materials and Submission of Billing Breakup (BBU) with matching the project cost.

- d. Obtaining approval of engineering drawing, technical data, operational manual etc and necessary inspection from the Purchaser.
- e. Complete manufacturing including shop testing.
- f. Procurement, Packing, forwarding, transportation and insurance of Equipment/ Material from the manufacturer's works to the Site.
- g. Material Supply, Receipt, storage, preservation, insurance and conservation of Equipment/ Material at the Site.
- h. Grading, clearing of vegetation of the Site such as bank of the Pond and Site of the Control Building.
- i. Design and assemble of floater & mounting structure and anchoring system for SPV panels.
- j. Providing power supply for construction purposes.
- k. Construction of RCC type Inverter room with Power conditioning unit and associated LT and HT switchgear.
- l. Construction of Equipments for switchgear room, SCADA room, store room, battery & Battery Charger room with all electrical fitting and Control room with Central Monitoring and Control Station, security cabin etc.
- m. Installation and commissioning of equipments as per technical design.
- n. All associated electrical and civil works required for interfacing with grid i.e. transformer(s), breakers, isolators, panels, protection system, cables. metering, earthing etc
- o. Power evacuation up to the terminal point at 33kV voltage level as specified in technical specifications.
- p. Water supply arrangement for Control Building.
- q. Construction of roads, walkways and drainage system of Control Building.
- r. SCADA system for remote monitoring and control of SPV panels with all hardware & software.
- s. Till the commissioning of the plant and handing over the same to the Purchaser, the necessary security arrangement of all the materials and equipments will be the sole responsibility of the Contractor.
- t. Final check-up of equipments, installation, and commissioning of power plant and putting the system into successful functional operation.
- u. Reliability tests, performance and guarantee tests, wherever applicable, on completion of commissioning.
- v. Insurance of all the Equipments/ Materials.

- w. Supply of Mandatory Spares.
 - a. Providing training to the purchaser operating personnel at Manufacturers works, Operating power stations and at site or abroad.
 - b. Providing training material to the end users during onsite training for end users.
 - c. Preparing commissioning certificate and documentation as per MNRE, GoI
 - d. Handing over of power plant.
 - e. Operation & maintenance of SPV Plant along with electrical equipments, consumables and spare parts for a period of five years from the date of successful completion of trial run.
 - f. Providing of routine and break down maintenance of grid connected floating solar PV power plants during comprehensive maintenance period.
 - g. Fulfilment of guarantee obligation.

1.3.2. SUPPLY:

The Supply scope includes the following but not limited to:

Manufacture / Procurement, Supply and delivery of all the materials like Floater, PV Module, Module Mounting Structure, Grid Connected Inverters, Transformer, String Monitoring Boxes, Inverter LT Panel, Grid Interfacing LT Panel, Web based monitoring systems, Weather Monitoring Systems, Cables, System protection and other accessories conforming to the Technical Specification as required for successful Installations commissioning of Floating Solar PV Power Plant at Sagardighi Thermal Power Project.

1.3.3. ERECTION AND OTHER SERVICES:-

The Erection and Commissioning scope includes the following but not limited to:

Installation, Testing and Commissioning of 10 MW Grid connected Floating Solar Photovoltaic Power Plants on Raw Water Pond No.1, 2 & 4 in Sagardighi Thermal Power Project(SgTPP), Murshidabad, West Bengal, India in turnkey basis including warranty obligation with 05 (Five) years comprehensive Operation and Maintenance.

1.3.4. OPERATION AND MAINTENANCE:

Five (5) years comprehensive Operation & Maintenance(O&M) of the Solar PV Plant including power evacuation along with electrical equipment, consumables and spare parts from the date of successful completion of trial run of the plant.

1.4 QUALIFYING REQUIREMENT FOR BIDDERS:

The Bidder must have to meet the following minimum qualification for 10MW grid connected Floating Solar PV Power Plant:

1.4.1. GENERAL :

The Bidder, who intends to participate in the Bid, must have to meet the following criteria:

1.4.1.1 The Bidder shall be a Sole Proprietorship / Firm or Company incorporated in India under the Companies Act, 1956 or 2013 or Indian Partnership Act 1932 or LLP Act 2008.

1.4.1.2 Bidders shall have to submit:

- a) i) **For the Companies** : Audited Balance Sheet and Statement of Profit and Loss Account of Last three (3) consecutive financial years for which the audited accounts are available (FY2016-17, FY2017-18 & FY2018-19)
- ii) **Other than Companies:** Tax Audit Report containing details for Last three (3) consecutive financial years (FY2016-17, FY2017-18 & FY2018-19)
- b) Acknowledgement of Income Tax Return for the last three Assessment Years (Assessment Year , 2017-18 & 2018-19, 2019-20)

1.4.1.3 The bidder must have valid GST, PF Registration, Return cum Challan (latest available) for Provident fund, ESI registrations are to be submitted along with the bid.

1.4.1.4 If the Bidder is **Bidding Consortium** then-

Joint Venture Bidders shall comply with the following requirements

- i) Number of members in a Joint Venture shall not exceed **3 (three)**;
- ii) Subject to the provisions of clause (i) above the Bid should contain the detail information required for each member of the Joint Venture, viz. Financial Capacity, Technical capacity etc. of each member;
- iii) Members of the Joint Venture shall nominate one member as the lead member (the "Lead Member"). Lead Member shall meet at least 50% requirement of Financial Capacity and at least

30% of Technical Capacity. The nominated Lead member shall remain unchanged during the entire period of project execution including the Defects Liability Period. The nomination(s) shall be supported by a Power of Attorney, as per the format at **(Form- 12)** Signed by all the other Members of the Joint Venture. Each of the other Member(s) shall meet at least 30% of the required Technical Capacity and 20% of the required Financial Capacity

- iv The duties, responsibilities and powers of Lead Member shall be specifically included in the joint Bidding Agreement or memorandum of understanding. It is expected that the Lead Member would be authorized to incur liabilities and to receive instructions and payments for and on behalf of the Consortium. The Lead Member should have maximum responsibility pertaining to execution of Project;
- v All the Consortium Member should fulfill the criteria as per clause no.1.4.1.
- vi The Bid should include a brief description of the roles and responsibilities of individual members, particularly with reference to financial, technical and defect liability obligations.
- vii All the members of the bidding consortium after the award and signing of the EPC Contract Agreement shall be obliged to continue to discharge their responsibility as the “members” of the consortium for a period covering the entire project completion period including defect liability plus Five (5) years of the Operation & Maintenance period of the total project. This five (5) years period shall be deemed to be effective from the date of commencement of the O&M period this project.
- viii The Bid should include a brief description of the roles and responsibilities of individual members which will satisfy the sub-clause 1.4. 1.4(iii) above;
- ix **Conflict of interest**-An individual Bidder cannot at the same time be a member of a Consortium applying for the Project. Further, a member of a particular Bidder Consortium cannot be member of any other Bidder Consortium applying for the Project;

- x No Change in the composition of the Consortium will be permitted by the Client during the Selection Process and during the subsistence of the Contract (in case the successful Bidder is a consortium).
- xi Members of the Consortium shall enter into a binding JV Bidding Agreement (herein after called as “JV/Consortium Agreement”), for the purpose of submitting a Bid. The notarized JV/Consortium Agreement, to be submitted along with the Bid as per format **Form-11** of the NIT.
- xii The award of the contract will be conferred on the Lead Member only(refer **clause-3.2.3**)

1.4.2. TECHNICAL ELIGIBILITY CRITERIA.

The Bidder, who intends to participate in the Bid, must have to meet the following criteria:

- i. The Bidder shall have experience of satisfactorily execution of contracts in Planning, Designing, Supply, Installation, Testing & Commissioning with comprehensive operation and maintenance of Grid connected Rooftop and/or Ground Mounted and/or Floating Solar PV Power plants at any organization /PSU/ Government Organization having capacity of at least **one(01) number 10(Ten) MWp or two(02) number 5(five)MWp** capacity or higher capacity project at a single location in each case during preceding 07 (Seven) years. This plant(s) should have been operating successfully for minimum 1 (one) year. The bidder shall furnish documentary evidences of satisfactory performances of the said solar power plants by way of submission of monthly generation data on annual basis along with performance certificates issued by the purchaser for minimum 1 (one) year.
- ii. The bidder should submit a list of contracts of similar nature already executed and presently under execution giving details of client, completion time, scope and value of work.
- iii. The Bidder should have minimum **1(one) number 10(Ten) MWp or 2(two) number 5(five) MWp** Rooftop or Ground Mounted or Floating Solar PV Power Plant Operation and Maintenance (O&M) experience which is in operational in India or abroad from last 1 years ending from last date of Bid Submission / Bid Due Date. The Bidder shall submit a latest O&M certificate issued by Project Developer of such plant.

- iv. If the Bidder is Bidding Consortium then the combined technical and financial capability of those Members in such consortium should satisfy the above conditions of eligibility.

1.4.3. FINANCIAL CAPABILITY:

The Bidder, who intends to participate in the Bid, must have to meet the following criteria:

- i.** Minimum Average Annual Turnover (MAAT) of the Bidder during the last 3 (three) financial years ending 31st March of the previous financial year shall be **Rs.18Cr.**
- ii.** Net worth as per the financial statement of the last financial year as referred in **clause no: 1.4.1. (a)** of this NIT should not be less than **100%** of the paid share capital of the bidder.
- iii.** If the Bidder is Bidding Consortium then combined Net Worth of the both partner should not be less than **100%** of the paid share capital of the bidder.
- iv.** If the Bidder is bidding Consortium then the combined MAAT of those Members in such consortium should satisfy the above conditions of eligibility.
- v.** **“Net worth”** means the aggregate value of the paid-up share capital and all reserves created out of the profits and securities premium account, after deducting the aggregate value of the accumulated losses, deferred expenditure and miscellaneous expenditure not written off, as per the audited balance sheet, but does not include reserves created out of revaluation of assets, write-back of depreciation and amalgamation;

1.4.4. OTHER QUALIFICATION REQUIREMENT

- 1.4.4.1 Bidder shall have adequate design, manufacturing and/or fabrication capability and capacity available to perform the work properly and expeditiously within the time period specified. The evidence shall specifically cover, with written details, the installed manufacturing and/or fabrication capacities and present commitments (excluding those anticipated under these bidding documents). If the present commitments are such that the installed capacity results in an inadequacy of manufacturing and/or fabrication capacities to meet the requirements appropriate to the works covered in his bid, then the details of alternative arrangements to be organized by the bidder and/or his

collaborator/associate for this purpose and which shall meet the Purchaser's approval, shall also be furnished.

1.4.4.2 Bidder shall have an adequate project management organization covering the areas related to engineering of Equipment/Materials, interface engineering, procurement of equipments and the necessary field services required for successful construction, testing and commissioning of all the Works covered in the scope of work for this package and as required by the bidding documents

1.4.4.3 Bidder shall have established quality assurance systems and organization designed to achieve high levels of system reliability, both during his manufacturing and/or fabrication and field installation activities

1.4.4.4 Notwithstanding anything stated herein, WBPDCCL reserves the right to inquire and review the bidder's capability and capacity to perform the work at the time of evaluation.

1.5 RESPONSIBILITY OF BIDDERS

1.5.1 The WBPDCCL will not assume any responsibility regarding information gathered, interpretations or conclusions made by the bidder or regarding information, interpretations or deductions the bidder may derive from the data furnished by the WBPDCCL. Verbal agreement or conversation with any employee of the WBPDCCL either before or after the submission of bid shall not affect or modify any of the terms or obligations contained herein.

1.5.2 It shall be the sole responsibility of bidders to determine and to satisfy themselves by such means as they consider necessary or desirable as to all matters pertaining to this bidding process including in particular all factors that may affect the cost, duration and execution of the work.

1.5.3 It must be understood and agreed by the bidders that factors which may affect the cost, duration and execution of the Works have properly been investigated and considered while submitting the bid. Claims whatsoever including those for financial adjustment in the price of the Contract awarded in accordance with these bidding documents will not be entertained by the Purchaser. Neither any change in time schedule of Contract nor any financial adjustments arising thereof shall be permitted by the Purchaser, which are based on the lack of investigation or its effect on the cost of the Contract to the bidder.

1.5.4 If the Bidder did not execute any Electrical Sub-station job of 33 kV or above voltage level then the Bidder have to engage WBPDC/WBSEDCL/WBSETCL approved vendor for 33kV Substation work.

1.6 COST OF BIDDING

The bidder shall bear all costs associated with the preparation and submission of his bid and WBPDC in no case shall be responsible or liable for these costs, regardless of the conduct or outcome of the bidding process.

B. THE BIDDING DOCUMENTS

1.7 CONTENTS OF BIDDING DOCUMENTS

The scope of work, bidding procedures, Contract terms and conditions and technical specifications are prescribed in the bidding documents. The set of bidding documents uploaded for the purpose of bidding includes the sections stated below together with any addendum/amendment to be issued in accordance with Clause No. **ITB. 1.11**.

	:	Notice Inviting Tender (NIT)
Section I	:	Instructions To Bidders (ITB)
Section II	:	Bid Data Sheet (BDS)
Section III	:	General Conditions of Contract (GCC)
Section IV	:	Special Conditions of Contract (SCC)
Section V		Technical specification
Section VI	:	Form
	1	Check List
	2	Forwarding Letter for submission of Bid Security and Tender Fee
	3	Bid Form/Undertaking
	4	Bid Security (Bank Guarantee format)
	5	Summary Statement of Yearly Turnover and Net Worth
	6	Capability Status
	7	Statement of Similar type of order, Orders executed as on date of issuance of NIT
	8	Curriculum Vitae of Key Personnel
	9	Format for Submission of Pre-Bid Queries
	10	Format for Proposed modifications

	11	JV/Consortium Agreement
	12	Power of Attorney
	13	Declaration for Net Minimum Guaranteed Generation
Section VII	Annexure	
	1	Proforma of Contract Agreement
	2	Proforma of Bank Guarantee for Mobilisation Advance
	3	Proforma of Bank Guarantee for Contract Performance
	4	Proforma for extension of Bank Guarantee
	5	Proforma of Indemnity Bond
	6	Completion Certificate
	7	Application for Payments
	8	Taking-Over Certificate
	9	No-Claim Certificate
	10A	Indemnity for Equipment
	10B	Application for Material Gate Pass
	11	Application for material gate pass
12	Authorization letter	

The bidder is expected to examine all instructions, forms, terms, conditions, specifications and other information in the bidding documents. Failure to furnish all information required as per the bidding documents or uploading of a bid not substantially responsive to the bidding documents in every respect will be at the bidder's risk and may result in rejection of his bid.

1.8 SITE VISIT

1.8.1 The bidder is advised to visit and examine the geographical location of Sites of work and its surroundings and obtain for himself on his own responsibility all information that may be necessary for preparing the bid, submission of offer and entering into a Contract for execution of works. The cost of visiting the site shall be borne by the bidder only.

1.8.2 The bidder and any of its authorized personnel or agents will be granted permission by the Purchaser to enter upon its premises and lands/Ponds for the purpose of such inspection, but only upon the express condition that the bidder, its personnel and agents will release and indemnify the Purchaser and its personnel and agents from and against all liability in respect thereof and will be responsible for death or personal injury, loss of or damage to property and any other loss, damage, costs and expenses incurred as a result of the inspection.

1.8.3 The site inspection shall be completed before the Pre-bid Meeting, if applicable or within 20 days after the NIT issue date, whichever is earlier.

1.9 CLARIFICATIONS ON BIDDING DOCUMENTS

1.9.1 A prospective bidder requiring any clarification on bidding documents may notify the WBPDCCL by uploading the same in the e-tendering portal, which shall be available to all the participant bidders, as per Standard Format enclosed with this document **Form 9** and **Form 10** not later than the date and time specified in NIT. The soft copy of the same must be sent in Excel format at the mail address : **Email: s.sengupta@wbpdcl.co.in**

1.9.2 The WBPDCCL will issue clarification(s) as it may think fit after pre-bid meeting prior to the deadline/ extended deadline for submission of bids prescribed by the WBPDCCL. Written copies of the WBPDCCL's response will be uploaded in the e-tendering portal in the corrigendum folder which shall be available to all the participant bidders

1.9.3 Any queries sent by the bidders after the date and time notified in NIT or any extended date, if any, shall not be entertained.

1.10 PRE-BID MEETING

1.10.1 The bidder or its authorized representative is invited to attend pre-bid meeting to be held on the date, time and location specified **in NIT or any specific change, which will be uploaded before the meeting date**. The purpose of the meeting will be to clarify the exact scope of work, and any issues regarding the bidding documents and the technical specifications for its clarification, if raised at this stage by the bidders. The Purchaser shall not be under any obligation to entertain /respond to the suggestions made or to incorporate modifications sought for by the prospective bidders.

1.10.2 Any modification/amendment of the bidding documents shall be made by the Purchaser exclusively through the issue of an amendment pursuant to **ITB. 1.11**

1.10.3 Non-attendance at the pre-bid meeting will not be a cause for disqualification of bidders but at the same time shall not entitle them to raise any query at a later date.

1.10.4 Any essential requirement not included in the Price Schedules but required for successful commissioning and operation of Works as per scope of Contract shall be indicated by the bidders as per **Form: 9** of Section VI and

submitted before the pre-bid meeting by the date specified in the NIT in line with **ITB. 1.9.1.** The Purchaser shall make related modifications/ amendments as may be considered necessary based on this form in the bidding documents as per provisions mentioned in this clause.

1.10.5 Bidders shall not be permitted to indicate any additional requirements in the bid for any reason whatsoever after the Purchaser has considered such amendments.

1.10.6 Venue of Pre bid meeting: WBPDCCL Corporate office, Kolkata

1.11 AMENDMENT OF BIDDING DOCUMENTS

1.11.1 At any time, but not later than seven (7) days prior to the deadline for submission of bids, the Purchaser may, for any reason, whether at its own initiative or in response to a clarification request by a prospective bidder, modify the bidding documents by issue of an addendum/amendment.

1.11.2 The addendum/amendment will be intimated through e-tendering portal at corrigendum folder. The Purchaser shall assume that the information contained therein have been taken into account by the bidder in its bid. The Purchaser will bear no responsibility or liability arising out of non-cognizance of the same in time or otherwise by the bidder.

1.11.3 In order to afford prospective bidders reasonable time in which to take the addendum/amendment into account in preparing their bids, Purchaser may, at its discretion, extend the deadline for the submission of bids.

1.11.4 WBPDCCL has the liberty to modify the bidding documents by issue of an addendum/amendment or to cancel the bid at any time.

1.11.5 For the information of bidders, the addendum/ amendments, if any, shall be uploaded on the e-tendering portal <https://wbtenders.gov.in>.

C. PREPARATION OF BIDS

1.12 DOCUMENT CONSTITUTE THE BID

1.12.1 Collection of Bid Document

The bidder can search & download NIT & Bid Document(s) electronically from e-tender portal <https://wbtenders.gov.in> once he/she logs on to the portal using the Digital Signature Certificate (DSC). This is the only mode of collection of Bid Documents.

1.12.2 **Language of the bid**

The bid prepared by the bidder and all correspondences and documents relating to the bid, exchanged between the bidder and the WBPDCCL shall be written in the **English language**, provided that any printed literature furnished by the bidder may be written in another language so long as the bid is accompanied by an English translation of its pertinent passages. Failure to comply with this may disqualify a bid. For purposes of interpretation of the bid, the English translation shall govern.

1.12.3 The bidder is expected to examine all instructions, forms, terms, conditions, Specifications and other information in the bidding documents. Failure to furnish all information required as per the bidding documents or uploading of a bid not substantially responsive to the bidding documents in every respect will be at the bidder's risk and may result in rejection of his bid.

1.13 **DEVIATION**

This tender is a '**No Deviation**' tender.

Request for any deviation may be considered only if pointed out by any bidder in the Pre Bid meeting. The queries and proposed modification regarding tender must be submitted by writing as per format (**Vide Form -9 and Form-10**) before pre bid meeting (**ITB. 1.10**)

1.14 **GENERAL GUIDANCE FOR E- TENDER**

Instructions/Guidelines for electronic submission of the tenders have been mentioned below for assisting the bidders to participate in e-Tendering.

1.14.1 **Registration of Bidder:**

Any bidder willing to take part in the process of e-Tendering will have to be enrolled & registered with the Government e-Procurement System, by logging on to **<https://wbtenders.gov.in>** The contractor is to click on the link for e-Tendering site as given on the web portal.

1.14.2 **Digital Signature certificate (DSC):**

Each bidder is required to obtain a Class-II or Class-III Digital Signature Certificate (DSC) for submission of tenders from the approved service provider of the National Informatics Centre (NIC) on payment of requisite

amount. Details are available at the Web Site stated above. DSC is given as a USB e-Token.

1.15 BID PRICES

Unless otherwise specified in the Technical Specification, Bidders shall quote for the entire works on a "Single Responsibility" basis such that the total bid price covers all the Contractor's obligations mentioned or to be reasonably inferred from the bidding documents in respect of design, manufacture, including procurement, packing, forwarding transportation, handling, insurance, delivery, installation, testing, pre-commissioning, commissioning, completion of the work and conductance of guarantee tests for the work including supply of spare (if any). This includes the acquiring of all permits, approvals and licenses etc as may be specified in the bidding documents. The bidder shall quote in the appropriate schedule for the proposed bid price for the entire scope of work covered under the bidding documents

1.15.1 PRICE SCHEDULE

1.15.2.1 **Price Schedule-1(Supply Schedule):** Price Schedule-1 will be consist of Ex-works price of Equipment / Materials, including type tests charges to be manufactured within/outside India i.e. basic cost (ex-factory, ex-works, ex-warehouse, or off-the-shelf, as applicable), then Transport, Loading, Unloading, Insurance Charge. This price shall be inclusive of all Tax and Duties (GST, Customs related Duties etc) payable on components and raw materials incorporated or to be incorporated in the goods. GST, Customs related duties and other tax and duties shall not be included in the ex-works price but shall be quoted separately in this Price Schedule. Local transportation including transit insurance, and Taxes to delivery of Equipment / Materials to the Site shall also be included in Price Schedule -1 i.e. Supply Schedule.

1.15.2.2 **Price Schedule-2(Erection Schedule):** Price for Installation and Erection service shall be quoted in the Price Schedule -2 (Service Schedule) and shall include the rates and prices for all labour, Contactor's Equipments Supply of consumables Materials and all matters and things of whatsoever nature, charges for insurance covers other than transit insurance The price schedule shall include the provision of operation and maintenance manuals, training of Purchaser and their nominated personnel and other services, as identified in the bidding documents and necessary for the proper execution of Installation and Erection Services. GST, Customs

related duties, BOCW cess and other tax and duties shall not be included in the service and consumables materials price but shall be quoted separately in this Price Schedule.

1.15.2.3 **Price Schedule-3(Operation and Maintenance):** Price for O&M contract shall be **10% of the basic project cost(excluding Tax and Duties) for 5(five) years** which is predefined and O&M contract shall be placed on this basis(refer clause-3.8.4.6).

1.15.2 The taxes, duties and levies shall be indicated by the bidder in the respective price schedule and shall be quoted as per the rates in force seven (7) days prior to the last date of submission of bids with respect of direct transaction between Contractor and Purchaser. Details of Tax and Duties will be guided by the **clause no. GCC 3.15**.

1.15.3 The bidder shall fill in price for all items described in the price schedules. Item against which no price is entered by the bidder will not be paid for by WBPDC when executed and shall be deemed to have been covered in other prices in the Price Schedule where the evaluation is being done on the basis of total prices quoted for all the Price Schedules.

1.15.4 All the prices shall be quoted in INR (Indian rupees) only. Foreign exchange component or foreign exchange variation will not be entertained for any reason whatsoever.

1.15.5 If any rebate/discount is offered, the overall discount in percentage shall be brought out in the Price Schedule. Conditional rebates/discount, if any, offered by any bidder shall not be considered during bid evaluation.

1.15.6 In case WBPDC observes that the L1 bidder has quoted abnormally low bid(less than 80% of estimated cost), the bid will be compared to the average of bid prices quoted by the other bidders. WBPDC then, shall ask the L1 bidder to produce detailed price analysis to demonstrate the justification of prices quoted in the bid. After evaluation, WBPDC may ask the bidder, at its discretion, to enhance the Performance Guarantee at the bidder's expense, by an extra 10% of L1 bid price as additional performance guarantee. Such additional performance guarantee shall remain valid up to ninety (90) days after the Defect Liability Period of sixty (60) calendar months and project execution period(12) months, with an additional claim period of ninety (90) days, failing which his bid security may be forfeited.

1.15.7 PRICE ADJUSTMENT

Price quoted by the bidder shall be firm during the entire period of contact and Bid evaluation will be done on the quoted price only.

1.16 PERIOD OF VALIDITY OF BIDS

- 1.16.1 The bids submitted by the bidder shall remain valid for a minimum period of **180 days** from the next day of opening of Technical bid. A bid valid for a shorter period than 180 days shall be rejected by the WBPDCCL.
- 1.16.1 In exceptional circumstances, WBPDCCL may solicit the bidder's consent to an extension of bid validity for a further period without any change in the terms and conditions of the NIT. The request and response thereto shall be made in writing by post or e-mail followed by post confirmation. The bidder may refuse the request without having his bid security forfeited. Bidders agreeing to the request will neither be required nor permitted to modify their respective bids, but will be required to extend the validity of their bid securities correspondingly. The provisions of ITB.1.17 regarding discharge and forfeiture of bid security shall continue to apply during the extended period of bid validity.

1.17 BID SECURITY

- 1.17.1 Bid Security /Earnest Money Deposit (EMD) of **Rs.120 lakh** must be submitted in form of Demand Draft (DD) / Banker's Cheque (BC) drawn in favour of **'The West Bengal Power Development Corporation Limited(WBPDCCL)'** payable at Kolkata issued from any schedule commercial Bank of India or in form of Bank Guarantee (BG) (Vide Form 4 Section-V) issued from any schedule Commercial Bank of India towards EMD as prescribed in the NIT, initially valid for **180 (One hundred Eighty) days** with claim period of another 3 (three) months, subject to further extension if required. Earnest Money in any other form or amount will not be accepted.
- 1.17.2 Bid security of the unsuccessful bidders will be discharged / returned as promptly as possible after the expiration of the validity of bid security or after the date of signing of Contract Agreement with the successful bidder whichever is earlier.
- 1.17.3 The bid security of the successful bidder will be discharged on furnishing the Performance Guarantee as per **ITB. 1.34** and signing of the Contract Agreement by the bidder.
- 1.17.4 If the bid security is not in adequate value the bid will be rejected by the

WBPDCCL and returned to the bidder with in thirty (30) days of the bid opening date.

1.17.5 The bid security shall be forfeited in the following circumstances:

- a) If the bidder withdraws its bid as a whole or in part as per **ITB.1.21**, during the period of bid validity specified by the bidder in its bid.
- b) If the bidder deviates from any clarification/confirmation given by him subsequent to submission of his bid.
- c) If the bidder does not accept the correction of its bid price pursuant to ITB. 1.26

1.17.6 If the successful bidder fails, within the specified time limit either to accept the Letter of Award (LoA) and sign the Contract Agreement unconditionally or, to furnish the Contract Performance Guarantee, in accordance with **ITB. 1.34**. No interest shall be paid by the Purchaser on the bid security.

1.18 SIGNING OF BIDS

All documents should be digitally signed by the bidders and uploaded by them.

D. SUBMISSION OF BID

1.19 SUBMISSION OF BID

1.19.1 Tenders are to be submitted through online to the website stated above in two folders at a time for each work, one in **Techno-commercial Proposal** & the other is **Financial Proposal** before the prescribed date & time using the Digital Signature Certificate (DSC). Virus scanned copy of the documents are to be uploaded duly digitally Signed. The documents will get encrypted (transformed into non readable formats).

1.19.2 General process of submission:

Bids are to be submitted online through the website **<https://wbtennders.gov.in>**. All the documents uploaded by the Tender Inviting Authority form an integral part of the contract. Bidders are required to upload all the Bid Documents along with the other documents, as asked for in the tender, through the above website within the stipulated date and time as given in the Tender. Tenders are to be submitted in two folders - one is **Techno-commercial Proposal** i.e. technical bid and the other is **Financial Proposal** i.e. financial bid. The bidder shall carefully go through

the documents and prepare the required documents and upload the scanned documents in Portable Document Format (PDF) to the portal in the designated locations of Technical Bid.

The bidder needs to download the Forms / Annexure, fill up the particulars in the designated cell and upload the same in the designated location of Technical Bid. The bidder needs to download the BOQ, fill up the BOQ in the designated Cell and upload the same in the designated location of Financial Bid in Excel.

The documents uploaded shall be virus scanned and digitally signed using the Digital Signature Certificate (DSC).

1.19.3 It is a two part bidding process so the offer contains two Proposals: a) Technical Proposal and b) Financial Proposal.

1.19.3.1 TECHNO-COMMERCIAL PROPOSAL:

The Technical Proposal shall contain scanned copies and/or declarations in the following standardized formats in two covers (folders). c1) Statutory Cover & c2) Non- Statutory Cover

c1. STATUTORY COVER:

Statutory contain three folders: 1) **“Tender fee and EMD”** folder 2) **“NIT”** Folder and 3) **“Form”** Folder.

1) “Tender Fee and EMD” folder:

i. Tender Fee

Scanned copy of CTS 2010 complaint Demand Draft (DD) / Banker’s Cheque (BC) towards tender fee as prescribed in the NIT, in favour of “The West Bengal Power Development Corporation Ltd(WBPDCCL)” ” payable at Kolkata.

ii. Earnest Money (EMD)/Bid Security

Scanned copy of Demand Draft (DD) / Banker’s Cheque (BC) drawn in favour of “The West Bengal Power Development Corporation Ltd (WBPDCCL)” payable at Kolkata from any scheduled commercial Bank of India or Bank Guarantee (BG) (**Form-4 Section-VI**) issued from any scheduled Commercial Bank of India towards EMD/bid security as prescribed in the NIT.

2) “NIT” Folder

- i. Addenda /Corrigenda: if published

Note: Bidders are to keep track of all the Addendum / Corrigendum issued with a particular tender and upload all the above digitally signed along with the NIT. Tenders submitted without the Addendum / Corrigendum will be treated as informal and liable to be rejected.

3) “Forms” folder:

- i. This folder will contain all the following vide **forms of section-VI**
- ii. Check List **(Form – 1)-document should submit accordingly,**
- iii. Forwarding Letter for submission of Bid Security and Tender Fee**(Form – 2)**
- iv. Bid Form **(Form – 3),**
- v. Summary statement of yearly turnover and net worth **(Form – 5)**
- vi. Capability Status **(Form – 6)**
- vii. Statement of Similar Type of Order. Orders Executed as on date of issuance of NIT **[Applicability up to the extent of meeting Technical QR]. (Form – 7).**
- viii. Curriculum Vitae of Key Personnel **(Form – 8).**
- ix. JV/Consortium Agreement**(Form-11)** –if JV/Consortium
- x. Power of Attorney**(Form-12)-** if JV/Consortium
- xi. Net Minimum Guaranteed Generation(NMGG) –**Form-13**

(Only downloaded copies of the above documents duly filled up and are to be uploaded, virus scanned and digitally signed by the bidder).

c2. NON STATUTORY COVER:

Sl. No.	Category Name	Detail(s)
A	Certificate(s)	1. Copy of the GST Certificate
		2. Copy of the PAN certificate/ PAN Card
		3. Declaration of PF Registration Number or Proof of PF Registration ,PF, ESI Challan etc

B	Company Detail(s)	5. Copy of the Registration Certificate under Company Act (Company Incorporation Certificate) or copy of the Registered Deed for Partnership Firm
C	Credential	6. Copy of the Order(s)/ Contract Agreement(s) with the Purchaser / any other Proof of Purchase, as primary agency [Applicability up to the extent of meeting Technical QR]. AND Corresponding Copy of the Completion Certificate(s) /Commissioning report signed by the Purchaser / Ordering Authority to substantiate the proof of completion of the Solar PV Power Plant(s). [Applicability up to the extent of meeting Technical QR].
D		7. Audited Balance Sheet & Statement of Profit & Loss A/c. [Applicability as per Financial capability].
		8. Copy of Acknowledgement of Income Tax returns [Applicability as per Financial capability].

Bidders are requested to submit all the documents as per the same serial in the following table given below.

1.19.3.2 FINANCIAL PROPOSAL

The Financial Proposal shall contain Price Bid and Mode of Transaction in the following standardized format i.e. file named BOQ –in Excels format.

BOQ

- i The BOQ to be filled up and upload is in form of Excel file in the BOQ folder (Cover)
- ii BOQ file consist of one worksheet with two part i.e. 1) Supply Schedule & 2) Erection Schedule
- iii Filling up procedure-
 - a) **Supply Schedule:** To be filled up by the bidders. It is related to the supply items as per **ITB. 1.15.2.1**

- b) **Erection Schedule:** To be filled up by the bidders. It is related to the corresponding erection of the equipment and other service item of the project as per **ITB.1.15.2.2**

The Material (e.g. civil cost) and Service Component for each item of the “Erection Schedule” should be correctly segregated by the vendor.

1.20 DEADLINE FOR SUBMISSION OF BIDS

- 1.20.1 The original Demand Draft/Banker's Cheque against Tender Fees and Earnest Money Deposit (EMD) must be submitted physically in the tender box at the office of the GM(M&C), Corporate office, WBPDCCL, under sealed cover super-scribing the name of the work with NIT no., name of the bidder, name of the work etc. on or before the date & time mentioned in the bid data sheet or any extension of date & time . If the bidder fails to submit the original copies within the due date and time his tender will not be opened and his bid will be rejected.
- 1.20.2 Bids must be received by WBPDCCL at the online e-tendering portal address specified in **NIT**, no later than the time and date mentioned in **NIT**.
- 1.20.3 The WBPDCCL may, at its discretion, under intimation to the bidders who have downloaded the bidding documents, extend the deadline for the submission of bids / opening of bids by issuing an addendum and hosting the same on the e-tender portal, in which case all rights and obligations of WBPDCCL and bidders previously subject to the original deadline shall thereafter subject to the deadline as extended.
- 1.20.4 In the event, the deadline for uploading of bid is extended by the WBPDCCL, the bidders who have already uploaded their bids within the original deadline of submission shall have the option to upload their revised bid in substitution either in full or in part of earlier bid. In the absence of a revised bid, the original bid shall be considered for opening and subsequent evaluation. Wherever, the bidder has submitted the revised bid in full, in modification of earlier bid, the earlier bid shall be returned unopened to the bidder.
- 1.20.5 Submission of original Tender Fee and Bid Security (**EMD**) (Offline Submission)
- a) The original copies of the DD/BC towards Tender Fee and DD/BC/BG towards EMD (Bid security) as per NIT shall be submitted along with a forwarding letter (**Form -2**) within the date and time as specified in the

bids.

- b) If the bidder fails to submit the original copies of the Tender fee and the Bid Security within the due date and time, his tender will not be opened and his bid will stand rejected.

1.21 WITHDRAWAL OF BIDS

The bidder shall not be permitted to withdraw their bid during the interval between bid submission deadline (as mentioned in NIT) and the period of bid validity as per **ITB.1.15**. If any withdrawal of bid is made by the bidder during the above period, it shall result in the forfeiture of the bid security

E. OPENING AND EVALUATION OF TENDER

1.22 BID OPENING

- 1.22.1 As it is a two part Bidding so WBPDCCL will open the bids electronically at e-tendering portal by the authorized personnel(s) using their Digital Signature Certificate (DSC), at the scheduled date & time for opening of bids as mentioned in NIT for techno-commercial bid(first part) and Financial bid(second part) will be opened on the date and time as intimated to the bidder on successful completion of evaluation of techno-commercial bids. The bidders' representatives who desire may attend/witness the bid opening event through e-tendering portal at their respective end. In the event of the specified date for the opening of bids being declared a holiday for the WBPDCCL or suspended for any involuntary reasons, the bids will be opened at the appointed time & date which shall be intimated/ communicated to all the intending bidders.
- 1.22.2 Bids that are not opened at bid opening will not be considered for further evaluation, regardless of the circumstances. The reason for which bids are not being opened will be notified to all the bidders through e-tendering portal.
- 1.22.3 The bidders' names, bid withdrawal and the presence or absence of the requisite bid security and such other details which WBPDCCL at his discretion may consider appropriate will be notified in the e-tendering portal at the bid opening date.
- 1.22.4 In this case of Single stage two part bids, on the date of opening of bid, the techno-commercial bid shall only be opened. The date for opening of the Price bid shall be intimated electronically at the appropriate time to the

bidders whose bid is found responsive in the techno-commercial evaluation.

- 1.22.5 In the event, Purchaser, in its discretion, decides not to open the bid for want of adequate response to the bidding, the Purchaser may either extend the bid submission deadline or cancel the bidding process any time before issuance of Letter of Award(LOA).

1.23 PROCESS TO BE CONFIDENTIAL

- 1.23.1 Subject to ITB. 1.24, no bidder shall contact the Purchaser on any matter related to its bid from the time of opening of the bids to the time the Contract is awarded.
- 1.23.2 Any effort by a bidder to influence Purchaser or others connected in the process of examination, clarification, evaluation and comparison of bids, and in decisions concerning the award of Contract, may result in the rejection of his bid.

1.24 CLARIFICATION OF BIDS

- 1.24.1 During bid evaluation, Purchaser may, at its discretion and if so required, ask the bidders for any clarification in support of their compliance to stipulated Qualifying Requirements (QR) or any other matter related to its bid except to the extent in ITB.1.24.2. The request for clarification required from the bidder and the response thereto shall be in writing and shall be delivered by registered speed post/email/courier / hand delivery under acknowledgement / email / fax so as to reach the Purchaser within the time specified in the request for clarification issued by Purchaser.
- 1.24.2 Any post-bid change in the price or substance (techno-commercial) of the bid shall not be sought, offered or accepted.

1.25 DETERMINATION OF RESPONSIVENESS

- 1.25.1 The Purchaser will examine the bids to determine whether they are complete, whether any computational errors have been made, whether required securities have been furnished, whether power of attorney of signatory of the bid has been submitted, whether the documents have been properly signed and whether the bids are generally in order and substantially responsive to the requirements of the bidding documents.
- 1.25.2 For the purpose of this clause, a substantially responsive bid is one which conforms to all the Terms, Conditions and Specifications of the bidding documents without material deviation or reservation. The Purchaser's determination of a bid's responsiveness shall be based on the contents of the

bid itself without recourse to extrinsic evidence.

- 1.25.3 Any material information/ data/ document required to be submitted by the bidders as per provisions of bidding documents, if not submitted by the bidder, may render the bid to be non-responsive provided such information/ data/ documents is such that it may adversely affect the evaluation.
- 1.25.4 The Purchaser may waive any minor infirmity, non-conformity or irregularity in a bid that does not constitute a material deviation, and that does not prejudice or affect the relative ranking of any bidder, as a result of the technical and commercial evaluation pursuant to **ITB. 1.28 & ITB. 1.29**.
- 1.25.5 If a bid is not substantially responsive to the requirements of the bidding documents, it may be rejected by Purchaser and the same cannot subsequently be made responsive by the bidder by correction.
- 1.25.6 Conditional bid shall not be accepted by Purchaser

1.26 CORRECTION OF ARITHMETICAL ERRORS IN PRICE BID

- 1.26.1 Arithmetical errors will be corrected at the time of evaluation of Price bid and the corrected figure will be considered as evaluated bid price. The corrections in the bid price shall be done as per the provisions of this clause and shall be binding on the bidder. If the bidder does not accept the correction of errors as per the provisions of this clause, his bid will be rejected and the bid security will be forfeited.
- 1.26.2 If there is a discrepancy between the product of unit price and quantity and the total price, the product of unit price and quantity will prevail and the total price will be corrected. If there is discrepancy between summation of subtotals and total price, the summation of subtotal price shall prevail, and the total price shall be corrected. If there is a discrepancy between words and figure, the amount in words will prevail. In case unit price or quantity or both are not filled in against any item, it will be treated as zero and will be assumed that the Bidder has absorbed the cost elsewhere in the Price Bid.
- 1.26.3 The total price so corrected shall be considered for the purpose of evaluation of bid. However for the purpose of award, the corrected price by the Purchaser or the bid price quoted by the bidder, whichever is lower, will be taken.
- 1.26.4 Bids will be corrected for the rates of taxes & duties in case of wrong rates taken by the bidder. For the purpose of bid comparison and evaluation, the

rates of taxes & duties in force as on seven (7) days prior to the last date of submission of bids would be considered, only in respect to direct transactions between the Contractor and Purchaser.

1.27 TIME SCHEDULE

The basic consideration and the essence of the Contract shall be the strict adherence to the time schedule specified in the Bids and NIT after the Commencement Date of the Contract as incorporated in the Contract Agreement for completion of Works. Bidders are required to base their prices on the time schedule mention in Clause no.**GCC 3.21**. No credit will be given for earlier completion for the purpose of evaluation.

1.28 PROCEDURE OF EVALUATION OF BIDS

1.28.1 The Purchaser will carry out a detailed evaluation of the bids determined to be substantially responsive as per clause no.**ITB 1.25** in order to determine whether the technical aspects are in accordance with the requirements set forth in the bidding documents. **Bids submitted by bidders with any deviations shall be rejected.**

1.28.2 The Purchaser will determine to its satisfaction whether the bidder selected as having submitted the lowest evaluated responsive bid is qualified to satisfactorily perform the Contract in terms of the qualifying requirements stipulated in NIT.

1.28.3 The determination will take into account the bidder's financial, technical, production and execution capabilities, in particular its work in hand and future commitments. It will be based upon an examination of the documentary evidence of the bidder's qualifications submitted by the bidder to the bid, as well as such other information as the Purchaser deems necessary and appropriate.

1.28.4 An affirmative determination will be a prerequisite for award of the Contract to the bidder. A negative determination will result in rejection of the bidder's bid, in which event the Purchaser will proceed to the next lowest evaluated bid to make a similar determination of that bidder's capabilities to perform satisfactorily.

1.29 COMPARISON OF BIDS

1.29.1 The bids shall be compared on the basis of 10 MW Solar PV Plant

installation and commissioning prices i.e. for ex-works price of supply portion including Tax and Duties, Insurance, transportation and ex-works prices for Materials, Services/Erection, Testing & Commissioning including Tax and Duties for the entire scope of the Works as defined in the bidding documents.

- 1.29.2 The bid prices shall be in Indian Rupees only and the minimum cost of 10 MW plant for Supply, Erection, Testing & Commissioning, Transportation, GST and other Tax and duties will be considered for selection of the lowest Bidder.

F. AWARD OF CONTRACT

1.30 AWARD CRITERIA

- 1.30.1 The Purchaser will award the Contract to the successful bidder(s) whose bid has been determined to be substantially responsive and has been determined as the lowest bid provided further that the bidder is determined to be qualified to perform the Contract satisfactorily. The Purchaser shall be the sole judge in this regard.

- 1.30.2 For the purpose of determining the capability and capacity of the bidder to perform the Contract, the Purchaser reserves the right to verify the authenticity of the documents submitted by the bidder for meeting the qualification requirements and may undertake verification of the facilities available with the bidder.

1.31 RIGHT TO REJECT BIDS

WBPDCCL reserves the right to accept or reject any bid and to annul the bidding process and reject all bids at any time prior to award of contract, without thereby incurring any liability to affected bidder or bidders or any obligation to inform the affected bidder or bidders the reason for WBPDCCL's action.

1.32 LETTER OF AWARD

- 1.32.1 After approval of bid evaluation by WBPDCCL, the successful bidder may be invited for pre-award discussions. After pre-award discussions and prior to the expiry of the period of bid validity, WBPDCCL will notify the successful bidder in writing by registered letter or E-mail, that his bid has been accepted. This letter ('Letter of Award' or **LOA or Material/Service Contract**) shall mention the sum which WBPDCCL will pay to the Contractor in consideration of the execution & completion of the Works by the

Contractor as prescribed under the Contract.

1.32.2 Within ten (10) days of receipt of the LOA, the successful bidder shall sign and return one (1) photocopy of the same to WBPDCCL as acknowledgment of acceptance of the same.

1.32.3 The **LOA or Material/Service Contract** will constitute the formation of the Contract as per provisions of **GCC.3.4.5**

1.33 SIGNING OF CONTRACT AGREEMENT

1.33.1 WBPDCCL will send the successful bidder the Contract Agreement (non judicial stamp paper of appropriate value) as per **Annexure: 1 of Section VII** in three (3) copies incorporating all agreements between the parties duly signed by the authorized signatory of the Purchaser along with the LOA.

1.33.2 Within thirty (30) days from the date of acceptance of LOA, the successful bidder shall sign the Contract Agreement and return two (2) copies to the Purchaser and retain one (1) copy of the same.

1.34 CONTRACT PERFORMANCE GUARANTEE

1.34.1 Within fifteen (15) days of LOA from WBPDCCL, the successful bidder shall furnish to WBPDCCL a Contract Performance Guarantee (CPG), as in the form of an unconditional and irrevocable Bank Guarantee equal to ten percent (10%) of the Contract Price for all the Contracts and as per the **Annexure: 2 of Section VII**.

1.34.2 Failure of the successful bidder to submit performance security as stated herein shall constitute sufficient ground for annulment of the award and forfeiture of his bid security, in which event the Purchaser may make the award to the next lowest evaluated bidder or call for new bids.

1.34.3 Forfeiture of Contract Performance Guarantee

Contract Performance Guarantee shall be forfeited if,

- a. The successful bidder does not execute the work after placement of Letter of Award (LOA) and/or,
- b. The successful bidder will discontinue the work without prior permission of WBPDCCL and/or,
- c. The successful bidder fails to install/procure the total capacity of the plant as mentioned in the Bid Document and/or,

- d. The successful bidder fails to rectify/replace of the defective/damaged equipment(s)/work(s) within the Defect Liability Period.

1.34.4 Additional Contact Performance Guarantee (ACPG)

If L1 bidder's quoted bid is 80% or less of the estimated project cost mentioned in this tender then additional Contact Performance Guarantee (ACPG) as in the form of an unconditional and irrevocable Bank Guarantee (BG) equal to ten percent (10%) of the Contract Price for all the Contracts and as per the **Annexure: 2 of Section VII** have to be submitted by the bidder in the form any scheduled bank before issuance of Work Order. If the bidder fails to submit the Additional Performance Security within schedule time, his EMD will be forfeited. The Additional Performance Security shall remain valid up to after the Defect Liability Period of sixty (60) calendar months and project execution period(12) months, with an additional claim period of ninety (90) days, failing which his bid security may be forfeited.

1.34.5 Forfeiture of Additional Contact Performance Guarantee (ACPG)

Additional Contact Performance Guarantee (ACPG) shall be forfeited if,

- a. The successful bidder does not execute the work after placement of Letter of Award (LOA) and/or,
- b. The successful bidder will discontinue the work without prior permission of WBPDCCL and/or,
- c. The successful bidder fails to install/procure the total capacity of the plant as mentioned in the Bid Document and/or,
- d. The successful bidder fails to rectify/replace of the defective/damaged equipment(s)/work(s) within the Defect Liability Period.

1.35 MISREPRESENTATION BY THE BIDDER

If the bidder conceals any material information or makes a wrong statement or misrepresents facts or makes a misleading statement in the bid, in any manner whatsoever, in order to create circumstances for the acceptance of the bid, the purchaser reserves the right to reject such bid and/or cancel the LOA **or Material/Service Contract**, if issued.

1.36 CORRUPT OR FRAUDULENT PRACTICES

- 1.36.1 The Purchaser requires that the Bidders/Contractors observe the highest standard of ethics during the procurement and execution of the Contracts.

- 1.36.2 In pursuance of this policy, the Purchaser defines, for the purposes of this provision the terms set forth below as follows:
- a. **“Corrupt practice”** means the offering, giving, receiving or soliciting of anything of value to influence the action of a public official in the procurement process or in Contract execution.
 - b. **“Fraudulent practice”** means a misinterpretation of facts in order to influence the procurement process or the execution of a Contract to the detriment of the Purchaser, and includes collusive practice among bidders (prior to or after bid submission) designed to establish bid prices at artificial non-competitive levels and to deprive the Purchaser of the benefits of free and open competition
- 1.36.3 The Purchaser will reject a proposal for award if it determines that the bidder recommended for award has engaged in corrupt or fraudulent practices in competing for the Contract in question
- 1.36.4 The Purchaser may declare a firm ineligible, either indefinitely or for a stated period of time, to be awarded a Contract if it any time determines that the firm has engaged in corrupt or fraudulent practices in competing for or in executing a Contract of the Purchaser
- 1.36.5 The bidders shall make themselves aware of the provision contained in **GCC.3.47.2.**

SECTION-II BID DATA SHEET

BID DATA SHEET (BDS)

The following bid specific data for the Equipment/ Materials / Works to be procured shall amend and/or supplement the clauses in the Instructions to Bidders (ITB). Whenever there is a conflict, the provisions herein shall prevail over those in the ITB.

Name of the Work:	Design & Engineering, Manufacture / Procurement, Supply, Erection, Testing and Commissioning of 10MW Phase-II Grid Connected Floating Solar Photovoltaic Power Plant on Raw Water Pond No.1, 2 & 4 in Sagardighi Thermal Power Project(SgTPP), Murshidabad, West Bengal including warrantee obligation with 05 (Five) years comprehensive Operation and Maintenance.
NIT No:	WBDCL/CORP/NIT/E1317/19-20 DTD: 12-03-2020

ITB Clause Ref., if any	Data
	2.1 A. SCOPE & QUALIFICATION
ITB. 1.2	WBDCL intends to finance this Works through fund as to be received from GoWB and MNRE GoI if any.
	End user of the Project The West Bengal Power Development Corporation Limited
ITB.1.3	Brief Scope of Work
ITB 1.4	QUALIFYING REQUIREMENT FOR BIDDERS: Prescribed in NIT
ITB 1.4.1.4	Whether Joint Venture is permitted - YES
	Type of Bidding: National Competitive Bidding (NCB).
	2.2 B. THE BIDDING DOCUMENTS
ITB.1.9	Clarification or any proposed modification on bidding document may be submitted by the bidders through mail to the mail address Email: s.sengupta@wbpdcl.co.in as per format of Form 9 and Form 10 of Section VI
	Date & Time up to which request for clarifications will be received: As per NIT

	Clarifications on bidding documents may be obtained from https://wbtenders.gov.in
	NOTE: Late submission of queries will not be entertained.
ITB. 1.10	Pre-bid Meeting Venue : The West Bengal Power Development Corporation Ltd. Bidyut Unnayan Bhaban, Plot No. 3/C LA-Block, Sector-III, Bidhannagar,Kolkata-700 106 Date & Time : As per NIT
ITB.1.10.4	The proposed modifications to the bid documents shall be sent by the bidders within the time mentioned in NIT through mail to the mail address Email: s.sengupta@wbpdcl.co.in as per format of Form 10 of Section VI
	2.3 C. PREPARATION OF BIDS
ITB.1.15.8	Price Adjustment is not applicable.
ITB.16.0	Period of validity of bids: As per NIT
ITB.1.18	Validity of Bid Security : As per NIT
	2.4 D. SUBMISSION OF BIDS
ITB.1.19.1	Bids should be submitted online through the portal
ITB.1.19.2	https://wbtenders.gov.in
ITB 1.20.4	Submission of original Tender Fee is Rs. 5900/- and Bid Security (EMD) (Offline Submission) an amount of Rs. 120 lakh. <u>Place of Submission</u> To The General Manager(M&C) , The West Bengal Power Development Corporation Ltd. Bidyut Unnayan Bhaban, Plot No. 3/C LA-Block, Sector-III, Bidhannagar,Kolkata-700 106 Telephone: 0091 – 033 2339 3621, Email: s.sengupta@wbpdcl.co.in Date & Time : As per NIT
ITB. 1.27	Time to complete the Works from the Date of LOA:- As per NIT
	Detailed Master Network for different activities [To be submitted by successful vendor/contractor]
	The Master Network shall include the major activities listed below showing their inter-relationship and duration so as to meet the schedule dates mentioned above:

	<ol style="list-style-type: none"> 1. Kick off Meeting 2. Start of engineering 3. Completion of engineering 4. Start of manufacturing/fabrication 5. Completion of manufacturing/fabrication 6. Commencement of supplies 7. Supplies all items 8. Completion of site delivery of spares 9. Commencement & completion of civil works (wherever applicable) 10. Commencement and completion of erection of equipments/materials. 11. Readiness of the system 12. PG test completion 13. Completion of Works
	<p>The master schedule and the key milestone dates will be discussed with the successful bidder and agreed upon before the issue of LOA. Engineering Drawing and Data Submission Schedule shall also be discussed and finalised before the issue of LOA.</p>
	<p>After the LOA, the Contractor shall plan the sequence of work of manufacture, supply and erection to meet the above stated dates of successful completion of Works and shall ensure all work, manufacture, shop testing, inspection and shipment of the Equipment/Materials in accordance with the required erection sequence.</p>

SECTION-III

GENERAL CONDITION OF CONTRACT (GCC)

A. CONTRACT AND INTERPRETATION

3.1. DEFINITION OF TERMS

Unless the context otherwise requires, the following terms whenever used in this document have the respective meaning:

- i. **“Purchaser”** shall mean the **“The West Bengal Power development Corporation Limited(WBPDC)”**, having its Office at Bidyut Unnayan Bhaban, Plot No. 3/C LA-Block, Sector-III, Bidhannagar, Kolkata-700 106 and shall include its successors and assigns.
- ii. **“Contract”** means all the Contract Agreement(s) entered into between the Purchaser and the Contractor, together with the Contract Documents referred to therein; they shall constitute the Contract and the term Contract shall in all such documents be construed accordingly.
- iii. **“Contract Document”** means the documents listed in Article 1.1 (Contract Documents) of the Contract Agreement (including any amendments thereto)
- iv. **“Contract Price”** means the sum total of contract price stated in all the Letter of Award(s) as payable to the Contractor for supply, execution and commissioning of the entire Works under the scope of Contract subject to such addition & adjustments thereto or deductions there from as may be made pursuant to the Contract(s). In cases where separate identifiable Works can be completed and taken over by the Purchaser and for which separate completion schedule is provided in the Contract, in relation to such

Works, the Contract Price shall mean the price related to such Works completed and taken over by the Purchaser.

- v. **“Contractor”** means the successful bidder whose bid has been accepted by the Purchaser, named as such in the Contract Agreement and included its legal successors and permitted assigns.
- vi. **“Contractor's Equipment”** means all appliances or things of whatsoever nature required for the purposes of execution of work and which are to be provided by the Contractor but does not include any Equipment/ Materials intended to form part of Works.
- vii. **“Bid”** shall mean the Qualification Bid, Technical Bid and Financial Bid submitted by the Bidder, in response to Notice Invite for Tender (NIT).
- viii. **“Bidder”** shall mean Bidding Company or a Bidding Consortium (formed through a memorandum of understanding) or any other person submitting the Bid. Any reference to the Bidder includes Bidding Company / Bidding Consortium / Member of a Bidding Consortium includes its successors, executors and permitted assigns and Lead Member of the Bidding Consortium jointly and severally, as the context may be.
- ix. **“Bidding Consortium”** shall mean a maximum of two(2) Bidding Companies who have signed a memorandum of understanding collectively submitted the Bid in accordance with the provisions of this RFQ cum RFP.
- x. **“Project Manager”** means the person appointed by the Purchaser in the manner provided in **GCC.3.19.1** hereof and named as such in the SCC to perform the duties delegated by the Purchaser.
- xi. **“Letter of Award”** means notice of acceptance of the bid in writing to the successful bidder, indicating the sum WBPDCCL will pay for the Works as per ITB

- xii. **“Price Schedule”** means the schedules or any part or individual schedule thereof, submitted by the bidder with his bid and forming a part of the Contract Documents.
- xiii. The **‘Engineer-in-Charge’** shall mean the Director (Projects) of the Company.
- xiv. The **“Controlling Officer”** shall mean the General Manager/Project In-charge of the respective Power Plants.
- xv. **‘WBPDCCL’s representative’** shall mean any person or persons or consulting firm appointed/authorized by the Company to supervise, inspect, test and examine workmanship and materials of the work under this scope.
- xvi. The **‘Sub-Contractor’** shall mean any person/agency to whom any part of the contract has been sublet by the contractor with the consent in writing of the Company and will include the legal representatives, successors and permitted assigns of such persons /agency.
- xvii. **‘Equipment/materials’** shall mean and include all type of construction equipment & materials etc. required for true and satisfactory completion of the work under this contract.
- xviii. **‘Workmanship’** shall mean the method/manner in which the jobs of the different items, whether included in the schedule or not but are required for true & satisfactory completion of the work under this contract, are executed.
- xix. **‘General Conditions’** shall mean all the clauses of General conditions of the proposed contract stated hereinafter. The specification shall mean the specification annexed to or issued with the General Conditions and shall include the schedule and drawings attached thereto.

- xx. The term **'Services'** shall mean all works to be undertaken by the contractor as laid down under the head "Scope of work" or elsewhere in the specification enclosed. When the words "approved", "subject to Approval". "As directed", "Accepted", "Permitted" etc. are used, the approval, judgment, direction etc. are understood to be a function of Company.
- xxi. **'Day'** means a calendar day beginning and ending midnight.
- xxii. **'Month'/'Calendar month'** means not only the period from the first of a particular month, but also any period between a date in a particular month, and the date previous to the corresponding date in subsequent month unless specifically stated otherwise.
- xxiii. **'Week'** means seven consecutive calendar days.
- xxiv. **'Writing'** shall include any manuscript, type written, printed or other statement reproduced in any visible form.
- xxv. **'Site'** means the place or places, where Works are to be executed by the Contractor or to which Equipment machinery are to be delivered, together with so much of the area surrounding the same as the Contractor shall with the consent of the Purchaser, use in connection with the work other than merely for the purposes of access.
- xxvi. **'Date of Contract'/'Commencement Date'** shall mean the date on which Letter of Award will be issued.
- xxvii. **'Zero Date'** will be started from the date of issuance of Letter of Award (LOA).
- xxviii. **'Program'** means the Program to be submitted by the Contractor in accordance with GCC and any approved revisions thereto.
- xxix. **'GCC'** means the General Conditions of Contract hereof.
- xxx. **'SCC'** means the Special Conditions of Contract.
- xxxi. **'Specifications'** shall mean collectively all the terms and

stipulations contained in this document including the conditions of contract, technical provisions and attachments thereto and list of corrections and amendments. **Drawings' means** collectively all the accompanying general drawings as well as all detailed drawings, which may be used from time to time or desired by WBPDCCL.

- xxxii. **'Approval'** shall mean the written approval of WBPDCCL and/the statutory authorities, wherever such authorities are specified by any codes or otherwise.
- xxxiii. **'Manufacturer'** shall refer to the party proposing to design/engineering and construct in complete or in part a particular job/work at their works/premises.
- xxxiv. **'Labourer'** shall mean all categories of labour engaged by the Contractor, his sub- contractors and his piece workers for work in connection with the execution of the works covered by the specifications. All these labourers will be deemed to be employed primarily by the Contractor.
- xxxv. **'Plant'/'Equipment'/'Stores'** means and include plant and machineries to be provided under the contract.
- xxxvi. **'Delivery of Plant'/'Delivery of Equipment'** shall be deemed to take place on delivery of the plant/equipment in accordance with the terms of the contract complete in all respect after approval by WBPDCCL.
- xxxvii. **'Tests on Completion'** shall mean all such tests as are prescribed by the specification to be made by the Contractor to the satisfaction of WBPDCCL before the plant and equipment are taken over by WBPDCCL and this also includes those tests not specifically mentioned in the specification but required under various BIS codes and relevant Electricity Acts and Rules.
- xxxviii. **'Commissioning'** shall mean the satisfactory, continuous and uninterrupted operation of the equipment/work as specified after all necessary initial tests, checks and adjustments required at site for a period of at least 15 (fifteen) days to the satisfaction of WBPDCCL.
- xxxix. **'Urgent Works'** shall mean any urgent measures, which in opinion of the Engineer-in- Charge, become necessary at

the time of execution and/or during the progress of work to obviate any risk of damage to the structure, or required to accelerate the progress of work or which become necessary for security or for any other/reason WBPDC may deem expedient.

- xl. "**MNRE**" shall mean Ministry of New and Renewable Energy, Government of India;
- xli. "**kWp**" shall mean Kilo-Watt Peak;

3.2. CONTRACT DOCUMENTS

3.2.1. CONSTRUCTION OF CONTRACT

The Contracts to be entered into between the Purchaser and the successful bidders shall be as under:

- a. "**FIRST CONTRACT**" is for ex-works supply of Equipment / Materials & Transport, transit insurance, unloading, storage, handling
- b. "**SECOND CONTRACT**" is for civil works as per Schedule of Works (Electrical & Civil), at Site, installation services (including rates and prices for all material/ labour, Contractor's Equipment, temporary works, consumables and all matters and things of whatsoever nature of such works), training of Purchaser's personnel etc and all other services specified in the Contract Documents.
- c. "**THIRD CONTRACT**" for Comprehensive Operation & maintenance for five (5) years which shall be conferred after successful completion of the project.

3.2.2. The award of these three Contracts shall not in any way dilute the responsibility of the Contractor for the successful completion of the Works as per Contract Documents.

3.2.3. If the successful bidder is a **Bidding Consortium** then the award of this three contract will be conferred on the **Lead Member**. But both the member of the consortium shall be severally and jointly liable and responsible for execution of the contract. In the event of failure on the part of the second member of the consortium to perform its obligation, then the Lead member of the consortium shall be solely responsible to fulfil the remaining obligations of its partner for the purpose of completion of contract

including statutory obligations(refer **Clasuse-3.49**).

- 3.2.4.** Subject to **SI no.2** of the Contract Agreement, all documents forming part of the Contract (and all parts thereof) are intended to be correlative, complementary and mutually explanatory. The Contract shall be read as a whole.
- 3.2.5.** Subsequent to signing of the Contract Agreement, the Contractor at his own cost shall provide the Purchaser with at least **six (6) copies** of the Contract Documents within **thirty (30)** days after signing of the Contract Agreement.
- 3.2.6.** The Contractor shall provide free of cost to PURCHASER all the engineering data, drawings and descriptive materials submitted with the bid, complete set of his bid and bidding documents, copies of all the correspondence with PURCHASER, etc. in at least **four (4)** copies to form a part of the Contract Documents immediately after the Letter of Award (**LOA**).
- 3.2.7. Endorsement of Terms**
The failure of either party to endorse at any time any of the provisions of the Contract or any rights in respect thereto or to an option herein provided shall in no way be construed to be a waiver of such provisions, rights or option or in any way to effect the validity of the Contract. The exercise by either party of any of his rights herein shall not preclude or prejudice either party from exercising the same or any other right it may have hereunder.
- 3.2.8. Effect**
The Contract shall be considered to come into force on the date of LOA by PURCHASER to the Contractor which may be in the form of a fax, E-MAIL or a Letter of Award. The Time for Completion shall be reckoned from that date
- 3.2.9.** All Contract Documents, all correspondence and communications to be given, and all other documentation to be prepared and supplied under the Contract shall be written in English, and the Contract shall be construed and interpreted in accordance with that language. If any of the Contract Documents, correspondence or communications are prepared in any language other than the governing language under this clause, the English translation of such documents, correspondence or communications shall prevail in matters of interpretation.

3.3. NOTICE

- 3.3.1.** Notices shall be deemed to include any approvals, consents, instructions, orders and certificates to be given under the Contract. Unless otherwise stated in the Contract, all notices to be given under the Contract shall be in writing, and shall be sent by personal delivery, Registered post or e-mail followed by post confirmation to the address of the relevant party as mentioned in SCC
- 3.3.2.** Any notice sent by registered post or speed post shall be deemed (in the absence of evidence of earlier receipt) to have been delivered **ten (10) days after dispatch**. In proving the fact of dispatch, it shall be sufficient to show that the envelope containing such notice was properly addressed, stamped and conveyed to the postal authorities for transmission by airmail or registered post.
- 3.3.3.** Any notice delivered personally or sent by registered post shall be deemed to have been delivered if the same is properly received by the other party.
- 3.3.4.** Either party may change its address at which notices are to be received by giving ten (10) days notice to other party in writing.

3.4. INTERPRETATION

- 3.4.1. Singular and Plural**
The singular shall include the plural and the plural the singular, except where the context otherwise requires.
- 3.4.2. Headings**
The headings and marginal notes in the General Conditions of Contract are included for ease of reference, and shall neither constitute a part of the Contract nor affect its interpretation.
- 3.4.3. Persons**
Words importing persons or parties shall include firms, corporations and government entities.
- 3.4.4. INCOTERMS**
Unless inconsistent with any clause of the Contract, the meaning of any trade term and the rights and obligations of parties there under shall be as prescribed by the Incoterms.
Incoterms means international rules for interpreting trade terms published by the International Chamber of Commerce (latest edition), 38 Cours Albert 1er, 75008 Paris, France.
- 3.4.5. Entire Agreement**
Subject to **GCC.3.17.3**, the Contract constitutes the entire

agreement between the Purchaser and Contractor with respect to the subject matter of Contract and supersedes all communications, negotiations and agreements (whether written or oral) of parties with respect thereto made prior to the date of Contract..

3.4.6. Independent Contractor

The Contractor shall be an independent Contractor (if JV/Consortium then Lead Member) performing the Contract.

The Contractor shall be solely responsible for the manner in which the Contract is performed. All employees, representatives or Sub-contractors engaged by the Contractor in connection with the performance of the Contract shall be under the complete control of the Contractor and shall not be deemed to be employees of the Purchaser, and nothing contained in the Contract or in any subcontract awarded by the Contractor shall be construed to create any contractual relationship between any such employees, representatives or Sub-contractors and the Purchaser.

3.4.7. Non-Waiver

Any waiver of Purchaser's/bidder's rights, powers or remedies under the Contract must be in writing, must be dated and signed by an authorized representative of the Purchaser/bidder granting such waiver, and must specify the right and the extent to which it is being waived.

Subject to above, no relaxation, forbearance, delay or indulgence by either party in enforcing any of the terms and conditions of the Contract or the granting of time by either party to the other shall prejudice, affect or restrict the rights of that party under the Contract, nor shall any waiver by either party of any breach of Contract operate as waiver of any subsequent or continuing breach of Contract.

3.4.8. Severability

If any provision or condition of the Contract is prohibited or rendered invalid or unenforceable, such prohibition, invalidity or unenforceability shall not affect the validity or enforceability of any other provisions and conditions of the Contract.

3.5. GOVERNING LAW

The Contract shall be governed by and interpreted in accordance with laws in force in India including any such Laws passed or made

or coming into force during the period of the Contract. The Courts of Kolkata under the superintendence of High Court of Calcutta shall have exclusive jurisdiction in all matters arising under the Contract.

3.6. DISPUTE RESOLUTION

3.6.1 If any dispute(s) or difference(s) of any kind whatsoever arise between the parties hereto in connection with or arising out of any contract, the parties hereto shall negotiate with a view to its amicable resolution and settlement. In the event no amicable resolution or settlement is reached within a period of 30 (thirty) days from the date on which the dispute(s) or difference(s) arose, either party shall give a notice to the other party, of such intention to invoke Arbitration within 14 (fourteen) days from the expiry of the aforesaid period of 30 (thirty) days within which amicable resolution could not be reached.

Such dispute(s) or difference(s) shall be referred to and settled by an Arbitral panel comprising of 3 (three) arbitrators. Both the parties shall appoint one arbitrator each. The third Arbitrator shall be appointed by both the Arbitrators who shall act as the Presiding Arbitrator.

3.6.2 If the appointed Arbitrators fail to agree upon the Presiding Arbitrator within 30 (thirty) days from the date of their appointment, the appointment of Presiding Arbitrator shall be made upon request of either party by, the Hon'ble High Court, Kolkata, West Bengal.

3.6.3 The Arbitration clause can be invoked at any time during the currency of the contract or after the expiry/ termination or closure of the contract.

3.6.4 The arbitration proceedings shall be in accordance with the prevailing Arbitration laws of India as amended or enacted time to time

3.6.5 The existence of any dispute(s) or difference(s) or the initiation or continuance of the Arbitration proceedings shall not permit the parties to postpone or delay the performance by the parties of their respective obligations pursuant to the Contract.

3.6.6 The seat of arbitration shall be Kolkata, West Bengal, India.

3.7. COMPLIANCE WITH LAWS

3.7.1 Compliance with Laws, statutes, regulations

The Contractor shall, in all matters arising in the performance of the Contract, comply with in all respects, give all notices and pay all fees required by the provisions of any national or state statute, ordinance or other law or any regulation or bye-law of any duly constituted authority.

3.7.2 Statutory Obligations

The Contractor shall adhere to the statutory provisions under Payment of Minimum Wages Act, Contract Labour (Regulation & Abolition) Act-1972, Employee's Provident Fund & Miscellaneous Provisions Act-1952, Employers' Compensation Act-1923, ESI Act and other available relevant statutes. At any point of time non-compliance of the statutory provisions in respect of contract labour engaged in the job by the contractor/sub-contractors may attract penal action against Contractor from the law enforcing authorities. All liabilities arising out of the non-compliance of the Law of the land will have to be borne by the Contractor and PURCHASER will not be responsible in any manner whatsoever for the same.

3.7.3 The Contractor shall indemnify and hold harmless the Purchaser from and against any and all liabilities, damages, claims, fines, penalties and expenses of whatever nature arising or resulting from the violation of such laws by the Contractor or its personnel, including the Sub-contractors and their personnel, but without prejudice to **GCC 3.10.1** hereof.

B. SUBJECT MATTER OF CONTRACT

3.8. SCOPE OF WORKS

3.8.1 Unless otherwise expressly provided in the Technical Specifications, the Contractor's obligations cover the provision of all Equipment/Materials including spares and the performance of all services required for the design, the manufacture (including quality assurance, construction, installation, associated civil, structural and other construction works and delivery) of the Equipment/Materials and the installation, commissioning, completion of the Works and carrying out completion tests for the

Works in accordance with the plans, procedures, Specifications, drawings, codes and any other documents as specified in the Technical Specifications. Such Specifications include, but are not limited to, the provision of supervision and engineering services; the supply of labour, materials, Equipment, spare parts (as specified in **GCC 3.8.3**) and accessories; Contractor's Equipment; construction utilities and supplies; temporary materials, structures and facilities; transportation (including, without limitation, unloading and hauling to, from and at the Site), insurance and storage, except for those supplies, works and services that will be provided or performed by the Purchaser.

3.8.2 The Contractor shall, at no extra cost to the Purchaser, unless specifically excluded in the Contract, perform all such Works and/or supply all such items and materials not specifically mentioned in the Contract but that can be reasonably inferred from the Contract as being required for attaining successful completion of the Works as if such Works and Materials were expressly mentioned in the Contract.

3.8.3 The Contractor agrees to supply spare parts required for the operation and maintenance of the Works as per provision of subsequent sub clauses of **GCC 3.8.3**.

3.8.3.1. All the spares for the Equipment/material under the Contract will strictly conform to the Specification and other relevant documents and will be identical to the corresponding main Equipment/Materials supplied under the Contract and shall be fully interchangeable.

3.8.3.2. All the spares covered under the Contract shall be manufactured along with the main Equipment/ Materials as a continuous operation and the delivery of the spares will be effected along with the main Equipment/ Materials in a phased manner and the delivery would be completed by the respective dates for the various categories of Equipment/ Materials as per the agreed Program.

3.8.3.3. The Contractor will provide the Purchaser with the manufacturing drawings, catalogues, assembly drawings and any other document required by the Purchaser so as to enable the Purchaser to identify the spares. Such details will be furnished to the Purchaser during design and drawing approval.

3.8.3.4. In addition to the spares covered in the Scope of Work, if the

Purchaser further identifies certain items of spares, the Contractor will submit the prices and delivery quotation for such spares within thirty (30) days of receipt of such request with a validity period of six (6) months for consideration by the Purchaser and placement of order for additional spares, if the Purchaser so desires.

- 3.8.3.5. The quality plan and the inspection requirement finalized for the main Equipment/ Materials will also be applicable to the corresponding spares.
- 3.8.3.6. The Contractor will provide the Purchaser with all the addresses and particulars of his Sub-contractors while placing the order for Equipment/ Materials covered under the Contract and will further ensure with his vendors that the Purchaser, if so desires, will have the right to place order for spares directly on them on mutually agreed terms based on offers of such vendors.
- 3.8.3.7. The Contractor shall guarantee the long-term availability of spares to the Purchaser for the full life of the Equipment/ Materials covered under the Contract. The Contractor shall guarantee that before going out of production of spare parts of the Equipment/ Materials, he shall give the Purchaser at least twelve (12) months advance notice so that the latter may order his bulk requirement of spares, if he so desires. The same provision will also be applicable to Sub-Contractor of any spares by the Contractor or his Sub-Contractors. Further, in case of discontinuance of manufacture of any spares by the Contractor or his Sub-Contractors, the Contractor will provide the Purchaser, two (2) years in advance, full manufacturing drawings, material specifications and technical information required by the Purchaser for the purpose of manufacture of such items..
- 3.8.3.8. In case the Contractor fails to supply the spares in the terms stipulated above, the Purchaser shall be entitled to purchase the same from the alternate sources at the risk and the cost of the Contractor and recover from the Contractor, the excess amount paid by the Purchaser, if any, over the rates worked on the above basis. In the event of such risk purchase by the Purchaser, the purchases will be as per the Policy and Procedures of the Purchaser prevalent at the time of such purchases and the Purchaser at his option may include a representative from the Contractor in finalizing the purchases.

3.8.3.9. It is expressly understood that the final settlement between the parties, in terms of relevant clauses of the Contract Documents shall not relieve the Contractor of any of his obligations under the provision of long term availability of spares unless otherwise discharged expressly in writing by the Purchaser.

3.8.3.10. The Contractor shall warrant that all spares supplied will be new and in accordance with the Contract Documents and will be free from defects in design, material and workmanship

3.8.4 COMPREHENSIVE OPERATION AND MAINTENANCE

Maintenance contract shall be commence after final commissioning of the plant. 05 (five) years comprehensive operation & maintenance of the plant shall also be the scope of work. The contractor needs to submit 03 (three) sets of comprehensive user's manual and 02 (two) sets of Operation and Maintenance manual book after commissioning of the plant.

The scope of maintenance shall include supply of spare parts, replacement of all damaged equipment and accessories with new one within the price of yearly maintenance charge.

Time for repair/ replacement of equipment or any works in case of any major failure will be granted by the Controlling Officer considering the type of failure and receiving written prayer from the contractor for the same. But in general the downtime will be 72 hours.

The period of unavailability of Grid & Force Majeure Conditions will not be considered as downtime.

Arrangement of security (Minimum 3 nos. of security personnel in each of the three shifts) shall be a scope of the operation and maintenance.

The contractor shall arrange sufficient transportation arrangement (24X7) for the operation and maintenance purpose. The maintenance includes Routine and preventive, Breakdown and Capital Maintenance which shall be but not limited to the following.

3.8.4.1. Routine and preventive maintenance:

This shall include:

- i. Regular cleaning of PV modules.
- ii. Checking & tightening of all electrical connections and

mechanical fittings.

- iii. Checking and restoring of earthing system.
- iv. Cleaning of Inverter and other electrical equipments.
- v. Routine maintenance as recommended by the original equipment manufacturer.

The contractor shall be responsible to carry out routine and preventive maintenance and replacement of each and every damaged/faulty component/ equipment of the power plant and he shall provide all labour, material, consumables etc for routine and preventive maintenance at his own cost.

3.8.4.2. **Breakdown maintenance:**

Breakdown maintenance shall mean the maintenance activity including repairs and replacement of any component or equipment of the power plant which is not covered by routine and preventive maintenance and which is required to be carried out as a result of sudden failure/breakdown of that particular component or equipment while the plant is running. The supplier shall be responsible to carry out breakdown maintenance of each and every component of the power plant and he shall provide the required manpower, materials, consumables, components or equipment etc. for breakdown maintenance at his own cost irrespective of the reasons of the breakdown/failure.

3.8.4.3. **Capital maintenance:**

Capital Maintenance shall mean the major overhaul of any component or equipment of the power plant which is not covered by routine, preventive and breakdown maintenance which may become necessary on account of excessive wear & tear, aging, which needs repair/replacement. The capital maintenance of power plant and all civil structures shall normally be planned to be carried out on an annual basis. For this purpose a joint inspection by the supplier and WBPDCCL shall be carried out of all the major components of the power plant, about two months in advance of the annual maintenance period, in order to ascertain as to which components of the power plant require capital maintenance. In this regard the decision of WBPDCCL will be final and binding.

However, if the condition of any plant component wants its capital maintenance at any other time, a joint inspection of WBPDCCL and supplier shall be carried out immediately on occurrence of such

situation and capital maintenance shall be carried out by arranging the shutdown of the plant/part of the plant, if required, in consultation with concerned authorities. The decision of WBPDC shall be final and binding to the contractor.

The capital maintenance also includes painting of mechanical & civil structures etc.

The contractor shall undertake necessary maintenance /troubleshooting work of the Solar PV Power Systems. Down time shall not be more than 72 hours from time of occurrence of such faults. Adequate measures should be taken for prevention of wear and tear of the machines. Solar PV Power System is to be designed to operate with a minimum of maintenance.

The scope of support service provides preventive maintenance as & when necessary within the contract period and break down maintenance in the event of malfunctions, which prevent the operation of the power system or part of it within the stipulated time period & free replacement of spares required for maintenance.

The contractor will provide Spare parts & measuring instruments.

The contractor shall submit the detailed schedule for routine and preventive maintenance before final commissioning of the plant. The contractor shall also submit Detailed Report to WBPDC for any capital or breakdown maintenance mentioning the cause of breakdown, actions taken to resolve that issue and preventive measures taken to avoid failure/damage/loss of generation due to similar incidents/accidents in future etc. within 07 (seven) days from the date of recovery.

3.8.4.4. **Maintenance Report:** Maintenance register / log book must be maintained at site. However, quarterly maintenance and monthly generation report of each location as per format duly approved by WBPDC must be submitted by the contractor to WBPDC with certification of Beneficiary in original by the contractor within 30 day of the following month. Failing of which maintenance service will be deemed to be not attended.

3.8.4.5. **Deployment of Competent Manpower:**

As the vendor is to satisfy the NMGG of the plant as per clause 3.33 so deployment of man power to be as per the site requirement.

3.8.4.6. **Cost & Payment Terms for O&M Contracts:**

O&M contract value: 10% of the Basic Project Cost (excluding Tax and Duties) for 5(five) years.

Payment Terms:

The payment shall be made on monthly basis and the Eligible amount will be due for payment after the certification by the Controlling Officer within 45 (forty five) days from the end of each month subject to satisfactory performance and submission of maintenance report in regular basis as mentioned in Clause no. 3.8.4 of GCC. The total yearly amount payable shall be subject to following table and as per certification of the Controlling Officer.

O&M Operation Year end	Amount of Payment
1 st Year	1.5% of the contract value
2 nd Year	2% of the contract value
3 rd Year	2% of the contract value
4 th Year	2% of the contract value
5 th Year	2.5% of the contract value

Tax and Duties will be paid extra

3.9. VARIATION, ADDITIONS AND OMISSIONS

The Contractor shall not modify the scope of work except under direction in writing by the WBPDCCL. The quantities provided in the schedule of works are fixed.

3.10. OBLIGATIONS OF THE CONTRACTOR

3.10.1 The Contractor shall, in accordance with the Contract, with due care and diligence, carry out the Works as necessary for successful completion of all the obligations, within the time for completion.

3.10.2 The Contractor confirms that it has entered into this Contract on the basis of a proper examination of the conditions and circumstances at the Site affecting the Contract Price, and on the basis of information that the Contractor could have obtained from a visual inspection of the Site including existing roads and bridges and other means of access to the Site, presence of obstructions on the Site. The Contractor acknowledges that any failure to acquaint itself with all such data and information shall not relieve its responsibility for properly estimating the difficulty or cost of successfully performing the Works

3.10.3 The Contractor shall acquire in its name all permits, approvals and/or

licenses from all local, state or national government authorities or public service undertakings in the country/ state where the Site is located that are necessary for the performance of the Contract.

3.10.4 The Contractor shall arrange/ construct at his own cost any storage/access, structures, bridges and approach to the work sites from public roads as may be required for execution of Works.

3.10.5 Contractor shall be responsible for all necessary statutory compliance in respect of the employees deployed by them or by the sub contractor(s) to execute the contract. However, Form no. V for obtaining labour license under the contract labour (R&A) act , 1970 and rules framed there under shall only be issued to the Contractor.

3.11. OBLIGATIONS OF THE PURCHASER

3.11.1 The Purchaser shall ensure the accuracy of all information and/or data to be supplied by the Purchaser as described in to the Contract Agreement, except when otherwise expressly stated in the Contract.

3.11.2 The Purchaser shall be responsible for providing legal and physical possession of the Site and access thereto except where providing access is included in the scope of work of the Contractor. The Purchaser shall give full possession of an accord all rights of access thereto on or after the date(s) of issuance of LoA.

3.11.3 The Purchaser shall acquire and pay for all permits, approvals and/or licenses from all local, state or national government authorities or public service undertakings where the Site is located, which such authorities or undertakings require the Purchaser to obtain in the Purchaser's name for the execution of the Contract (they include those required for the performance by both the Contractor and the Purchaser of their respective obligations under the Contract).

3.11.4 Without prejudice to the obligations of the Contractor under the Contract Agreement, if requested by the Contractor, the Purchaser shall use its best endeavours to assist the Contractor in obtaining in a timely and expeditious manner all permits, approvals and/or licenses necessary for the execution of the Contract from all local, state or national government authorities or public service undertakings that such authorities or undertakings require the Contractor or Sub-contractors or the personnel of the Contractor or Sub-contractors, as the case may be, to obtain.

3.11.5 The Purchaser shall provide sufficient, properly qualified operating and maintenance personnel; shall supply, other materials and

facilities and shall perform work and services of whatsoever nature to enable the Contractor to properly carry out Commissioning and Guarantee Tests at or before the time specified in the Program furnished by the Contractor under **GCC 3.23.2** hereof and in the manner thereupon specified or as otherwise agreed upon by them and make available all raw materials, utilities, lubricants, chemicals, catalysts Purchaser and the Contractor.

- 3.11.6 The Purchaser shall be responsible for facilitating the Test(s) on completion of the Works, in accordance with **GCC 3.28**

C. PAYMENT

3.12. CONTRACT PRICE

- 3.12.1 The Contract Price shall be as specified in **Article 4** of the Contract Agreement.

- 3.12.2 Subject to **GCC 3.11.1** hereof, the Contractor shall be deemed to have satisfied itself as to the correctness and sufficiency of the Contract Price, which shall, except as otherwise provided for in the Contract, cover all its obligations under the Contract.

3.13. TERMS AND PROCEDURE FOR PAYMENT

The payments to the Contractor for the performance of the Contract will be made by the Purchaser as per terms and conditions specified in **Clause 4.3.4.6**. No payment made by the Purchaser herein shall be deemed to constitute acceptance by the Purchaser of the Works or any part thereof. The currency of payment shall be Indian rupees.

3.14. SECURITIES

3.14.1 Mobilisation Advance Payment

10 % of the Contract Price (Supply & Erection contract) will be paid as Mobilization advance with interest to the contractor against submission of BG (**Annexure-3**) equivalent to 110 % of the Mobilization Advance. The payment of Mobilisation advance shall be subject to deduction of tax at source as per law.

This Bank Guarantee shall be returned to the Contractor after full recovery of advance with interest and against request by the Contractor. The validity of Bank Guarantee would require to be extended by the Contractor, if so required by the Purchaser. The details terms and Condition of the Mobilisation Advance specified in **Clause no. 4.3.4.2**.

3.14.2 Contract Performance Bank Guarantee(PBG)

- 3.14.2.1. The Contractor shall furnish an unconditional and irrevocable Bank

Guarantee in favour of the Purchaser as per **Annexure-2** of **Section VII**, towards Performance guarantee for faithful and due fulfilment of all obligations under the Contract after placement of LOA. Bank Guarantee shall be furnished for an amount equal to ten percent (10%) of the Contract Price of all the Contracts, from a Scheduled Bank in India. The Bank Guarantee shall be valid for Seventy Two (72) months including Defect Liability Period (Five year) with further claim period for ninety (90) days thereafter. The value of the Bank Guarantee is not to be construed as limiting the damages under Defects Liability Period. The Purchaser reserves the right to verify the authenticity of the Bank Guarantee from the issuing bank.

3.14.2.2. The Contract Performance Bank Guarantee is liable to be invoked on demand of PURCHASER, for any breach under the Contract irrespective of any dispute or difference between PURCHASER and the Contractor, pending before any court, tribunal or any other authority,

3.14.2.3. The Performance Bank Guarantee shall be returned to the Contractor within ninety (90) days after receipt of application for release of Performance Bank Guarantee along with certification regarding completion of Defects Liability Period and O&M period. No claim shall be made against the Performance Guarantee after the issue of Defects Liability Certificate. However, no costs shall be paid for the Bank Guarantee by the Purchaser, irrespective of date of release.

3.15. TAXES, DUTIES, LABOUR CESS AND OTHER LEVIES

3.15.1 Except as otherwise specifically provided in the Contract, the Contractor shall bear and pay all the applicable taxes and duties (**GST, Custom related Duties, BOCW Labour welfare cess as per laws** and other Govt. Tax or Levies) and charges assessed on the Contractor, its Sub-contractors in connection with this Works. All applicable taxes, duties and levies, (GST and Customs related Duties) where applicable and payable on Equipment/Materials, components, sub-assemblies, raw materials and any other item required for manufacture of finished Equipment/Material or completion of Works shall be deemed to have been included in price.

3.15.2 The Contractor shall be solely responsible for the taxes that may be levied on the Contractor's persons or on earnings of any of his employees and shall hold the Purchaser indemnified and harmless against any claims that may be made against the Purchaser. The

Purchaser does not take any responsibility whatsoever regarding taxes under Indian Income Tax Act, for the Contractor or his personnel. If it is obligatory under the provisions under the Indian Income Tax Act, deduction of Income Tax at source shall be made by the Purchaser.

3.15.3 For the purpose of the Contract, it is agreed that the Contract Price specified in the Contract Agreement is based on the taxes, duties, levies and charges prevailing at the date seven (7) days prior to the last date of bid submission (hereinafter called "Tax" in this paragraph).

3.15.4 For this EPC Contracts the total project cost/ contract cost (inclusive of Taxes & Duties) will remain fixed throughout the contract. Therefore in case of any increase in rates of existing Taxes & Duties during the currency of the contract the bidder has to adjust the base price to keep the landed price fixed vis-a-vis in case of any decrease in rates of existing Taxes & Duties during the currency of the contract the same shall be at the cost of WBPDC.

3.15.5 GST will be paid at actual by the PURCHASER up to the ceiling quoted in the price bid towards GST. TAX amount during LOA shall remain firm for the entire project period.

3.15.6 Customs related Duty (if Applicable)

3.15.5.1. The Contractor is requested to identify the value of imported components, if any and its price and accordingly the custom duty of its and should mention the value of the custom duty in the price bid.

3.15.5.2. Customs duty will be paid at actual (based on the bill of entry) by the PURCHASER up to the ceiling quoted in the price bid towards customs duty.

3.15.5.3. Any Customs duty variation due to exchange rate also will be paid at actual (based on Bill of entry) within the contractual delivery period. However if the project is delayed beyond the schedule date due to reasons attributable to the Contractor then the additional cost liability, if any shall have to be borne by the Contractor.

3.15.5.4. All taxes and duties payable outside India shall be borne and paid by the contractor. No claim will be entertained by the PURCHASER whatsoever on this account.

3.15.7 Advance Payment

The GST payable if any in respect of advance payment may be paid to

the contractor by the PURCHASER in addition to the amount of advance, subject to providing appropriate documentary evidence that GST on advance has been paid by the contractor.

3.15.8 Tax Deduction at Source (TDS) towards Income Tax/Other Taxes

Deduction of Tax at source at prevailing rate shall be effected by the PURCHASER before payment as a statutory obligation wherever applicable. Income tax and all other taxes as applicable as per statutory obligation/s enactments shall be progressively deducted from the payments released to Contractor, by the PURCHASER, for depositing with the Income tax/other Tax authorities as per Income Tax Act.

TDS on Works Contract shall be deducted at source by the PURCHASER as per statutory provisions. However, if "No Deduction at Source Certificate" is furnished from the Tax Authorities by the Contractor, deduction of TDS on Works Contract shall not be effected.

3.15.9 Personal Income Tax & Cess

Income Tax and cess, if any payable by the Contractor's Sub-contractor's employees shall be paid by the said employees directly, and the PURCHASER shall not be liable to pay the income tax & cess payable by the employee of the contractor/sub contractor and the purchaser is not responsible for filing the tax returns of contracts employees/experts.

3.15.10 Reverse Charge Mechanism

In case the liability to discharge GST is on the employer under reverse charge mechanism, then the said fact should be clearly mentioned on the face of the invoice. Further, GST should not be charged by the vendor in such cases.

3.15.11 It shall be responsibility of the Contractor to comply with all the requirements prescribed in the GST Act and Rules as may be applicable in respect of the activities/supply made by them under the contract to enable the PURCHASER to avail entire input tax credit on timely basis. It is the responsibility of the vendor to comply with the following key compliance requirements, failing which the Contractor shall be responsible of any loss of tax credit or any other cost including interest, penalty, etc that may levied or recovered from the

employer.

- i. The contractor shall issue a proper tax invoice containing all the particulars as prescribed in the GST Invoice.
- ii. The Contractor shall deposit the GST amount due to the Government on a timely basis.
- iii. The Contractor shall file the periodic statements/returns as per the provisions of GST Law on a timely basis and include therein details of all the invoices raised during the relevant month under the present contract.
- iv. The Contractor shall support WBPDCCL on a best effort and timely basis to sort out the discrepancies communicated by GSTIN, if any.

3.15.12 Under GST regulation, taxes are levied on deductions under Liquidated Damage (LD). Such taxes will be charged extra by WBPDCCL. The rate of such tax on LD would be as per laws applicable at the time of imposition of LD when a Debit Note/Invoice is raised by WBPDCCL. This is because LD is a post delivery/performance event & is not part of initial price bid.

D. INTELLECTUAL PROPERTY

3.16. PATENT RIGHTS & ROYALTIES

3.16.1 Royalties and fees for patents covering Equipment/Materials, articles, apparatus, devices or processes used in the Works shall be deemed to have been included in the Contract Price. The Contractor shall satisfy all demands that may be made at any time for such royalties or fees and he alone shall be liable for any damages or claims for patent infringements and shall keep the Purchaser indemnified in that regard.

3.16.2 The Contractor shall, subject to the Purchaser's compliance with GCC.16.3, indemnify and hold harmless the Purchaser, his successors or assignees, its employees and officers from and against any and all suits, actions or administrative proceedings, claims, demands, losses, damages, costs, and expenses of whatsoever nature, including attorney's fees and expenses, which the Purchaser may suffer as a result of any infringement or alleged infringement of any patent, utility model, registered design, trademark, copyright or other

intellectual property right registered or otherwise existing at the date of the Contract by reason of : (a) the installation of the Works by the Contractor or the use of the Works in the country where the Site is located; and (b) the sale of the products produced by the Works in any country. Such indemnity shall not cover any use of the Works or any part thereof other than for the purpose indicated by or to be reasonably inferred from the Contract, any infringement resulting from the use of the Works or any part thereof, or any products produced thereby in association or combination with any other Equipment/ Materials not supplied by the Contractor, pursuant to the Contract Agreement.

3.16.3 If any proceedings are brought or any claim is made against the Purchaser arising out of the matters referred to in **GCC 3.16.2**, the Purchaser shall promptly give the Contractor a notice thereof, and the Contractor may at its own expense and in the Purchaser's name conduct such proceedings or claim and any negotiations for the settlement of any such proceedings or claim. If the Contractor fails to notify the Purchaser within thirty (30) days after receipt of such notice that it intends to conduct any such proceedings or claim, then the Purchaser shall be free to conduct the same on its own behalf. Unless the Contractor has so failed to notify the Purchaser within the thirty (30) day period, the Purchaser shall make no admission that may be prejudicial to the defence of any such proceedings or claim.

3.16.4 The Purchaser shall, at the Contractor's request, afford all available assistance to the Contractor in conducting such proceedings or claim, and shall be reimbursed by the Contractor for all reasonable expenses incurred in so doing.

3.16.5 All design and drawings submitted by the Contractor will be the property of Purchaser. The Purchaser reserves the right to use the same in its future project without any further reference and additional charges to the Contractor for such use.

3.16.6 The Purchaser's Drawings, Specification and other information submitted by the Purchaser to the Contractor shall remain the property of the Purchaser. They shall not, without the consent of the Purchaser, be used, copied or communicated to a third party by the Contractor unless necessary for the purposes of the Contract. Any error in any such drawing/Specification etc. shall not absolve the

Contractor of his responsibility.

3.17. CONFIDENTIAL INFORMATION

3.17.1 The Purchaser and the Contractor shall keep confidential and shall not, without the written consent of the other party hereto, divulge to any third party any documents, data or other information furnished directly or indirectly by the other party hereto in connection with the Contract, whether such information has been furnished prior to, during or following termination of the Contract. Notwithstanding the above, the Contractor may furnish to its Sub-Contractor(s) such documents, data and other information it receives from the Purchaser to the extent required for the Sub-contractor(s) to perform its Works under the Contract, in which event the Contractor shall obtain from such Sub-contractor(s) an undertaking of confidentiality similar to that imposed on the Contractor under this Clause GCC 3.17.

3.17.2 The obligation of a party under GCC 3.17.1 above, however, shall not apply to that information which

- a. now or hereafter enters the public domain through no fault of that party
- b. can be proven to have been possessed by that party at the time of disclosure and which was not previously obtained, directly or indirectly, from the other party hereto
- c. otherwise lawfully becomes available to that party from a third party that has no obligation of confidentiality

3.17.3 The above provisions of this Clause GCC 3.17 shall not in any way modify any undertaking of confidentiality given by either of the parties hereto prior to the date of the Contract in respect of the Works or any part thereof

3.17.4 The provisions of this Clause GCC 3.17 shall survive termination, for whatever reason, of the Contract.

3.18. ADVERTISING

Any advertising stating the subject of this Contract by the Contractor in India or in foreign countries shall be subject to approval of the Purchaser prior to the publication. Publication of approved articles, photographs and other similar materials shall carry acknowledgment to the Purchaser.

E. WORK EXECUTION

3.19. PURCHASER'S REPRESENTATIVE

- 3.19.1** The PURCHASER shall appoint an experienced engineer designated as the **Project Manager** who shall carry out the functions and obligations of the Purchaser under the Contract.
- 3.19.2** The PURCHASER may from time to time appoint some other person as the Project Manager in place of the person previously so appointed, and shall give a notice of the name of such other person to the Contractor without delay. The PURCHASER shall take reasonable care to see that no such appointment is made at such a time or in such a manner as to impede the progress of Works. The Project manager shall represent and act for the Purchaser at all times during the currency of the Contract.
- 3.19.3** Any decision, instruction or approval given by the Project Manager to the Contractor shall have the same effect as though it had been given by the Purchaser.
- 3.19.4** All notices, instructions, orders, certificates, approvals and all other communications under the Contract shall be given by the Project Manager, except as herein otherwise provided. All notices, instructions, information and other communications given by the Contractor to the Purchaser under the Contract shall be given to the Project Manager, except as herein otherwise provided.
- 3.19.5** The Project Manager may authorize his representative as site-in-charge for the Works. The Project Manager will also be the consignee officer for the Works.

3.20. CONTRACTOR'S REPRESENTATIVE

- 3.20.1** If the Contractor's representative is not named in the Contract, then the Contractor shall appoint the Contractor's representative and shall request the Purchaser in writing to approve the person so appointed. If the Purchaser makes no objection to the appointment, the Contractor's representative shall be deemed to have been approved. If the Purchaser objects to the appointment within fifteen (15) days giving the reason thereof, then the Contractor shall appoint a replacement of such objection, and the foregoing provisions of this Sub-Clause GCC 3.20.1 shall apply thereto.

- 3.20.2** The Contractor's representative shall represent and act for the Contractor at all times during the currency of the Contract and shall give to the Project Manager all the Contractor's notices, instructions, information and all other communications under the Contract.
- 3.20.3** Any instruction or notice which the Purchaser gives to the Contractor's representative(s) shall be deemed to have been given to the Contractor. An instruction book shall be kept at Site to record instruction of the Purchaser or his representative at the time of Site visit.
- 3.20.4** The Contractor shall not revoke the appointment of the Contractor's representative without the Purchaser's prior written consent, which shall not be unreasonably withheld. If the Purchaser consents thereto, the Contractor shall appoint some other person as the Contractor's Representative, pursuant to the procedure set out in GCC 3.20.1
- 3.20.5** The Contractor's representative may, subject to the approval of the Purchaser (which shall not be unreasonably withheld), at any time delegate to any person any of the powers, functions and authorities vested in him or her. Any such delegation may be revoked at any time. Any such delegation or revocation shall be subject to a prior notice signed by the Contractor's representative, and shall specify the powers, functions and authorities thereby delegated or revoked. No such delegation or revocation shall take effect unless and until a copy thereof has been delivered to the Purchaser and the Project Manager. Any act or exercise by any person of powers, functions and authorities so delegated to him or her in accordance with this Sub-Clause GCC 3.20.5 shall be deemed to be an act or exercise by the Contractor's representative.
- 3.20.6** The Contractor shall in addition to a Contractor's representative, employ one or more competent representative(s) to superintend the carrying out of the Works at Site. Such representative shall be fluent to communicate in local language for day to day work. Their names and contact addresses shall be communicated in writing to the Purchaser before commencement of Works.
- 3.20.7** The Purchaser may, by notice to the Contractor, object to any representative or person employed by the Contractor in the execution of the Contract ,who, in the reasonable opinion of the Purchaser, may behave inappropriately, may be incompetent or negligent, or may commit a serious breach of the Site regulations provided under

GCC.3.26.6. The Purchaser shall provide evidence of the same, whereupon the Contractor shall remove such person from the Site.

3.20.8

If any representative employed by the Contractor is removed in accordance with GCC 3.20.7 the Contractor shall, where required, promptly appoint a replacement

3.21. MILESTONE OF PROJECT

The whole work must be completed within **365 (Three Hundred Sixty Five)** days from the date of issuance of 'Letter of Award'. The duration of milestone will be calculated from the date of Letter of Award'.

Sl. No.	Description	Completion Time
1.	Approval of Detailed Design Report	65 Days
2.	Finalizations of Plant layout (including Modules, cable routes, inverter Control Room)	3 Months
3.	Completion of Supply of Floaters & Modules	9 Months
4.	Completion of construction of Inverter Control Room	10 Months
5.	Completion of Modules & Electrical Equipment Erection	11Month
6.	Completion of charging	12 Moths

Detailed time schedule for the site work has to be prepared based on the aforesaid milestones. Bidder has to submit the Detailed Design Report with complete time schedule within the milestones aforesaid. At the time of execution if delay occurs time extension may be allowed on the basis from request from Bidder. However all such time extension order shall be without prejudice to the terms and condition of the contract.

Company shall have the right, without prejudice to any other clauses, to terminate contract forthwith and to take possession of the balance work/materials and have the same allotted to any other agency and the contractor shall be liable to compensate the loss that may be occasioned to the Company on that account. Any letter in writing by the Controlling Officer shall be treated as conclusive on behalf of the

Company.

3.22. SUBMISSION OF DETAILED DESIGN REPORT

The contractor shall submit 03 (three) sets of the Draft Detailed Design Report along with editable soft copy in a compact disk for approval.

Draft Detailed design report shall contain all requisite documents as mentioned in the 'Scope of Work'. The contractor should submit the same within 30 (Thirty) days from the date of issuance of 'Letter of Award' for approval.

The contractor shall submit 05 (five) sets of the approved Detailed Design Report along with editable soft copy in a compact disk to the Director(Project), WBPDCCL within 60 (Sixty) days from the date of issuance of 'Letter of Award' to carry out further course of action.

3.23. PROGRAMME

3.23.1 The Contractor shall supply to the Purchaser and the Project Manager a chart showing the proposed organization to be established by the Contractor for carrying out the Works. The chart shall include the identities of the key personnel together with the curricula vitae of such key personnel to be employed after placement of LOA. The Contractor shall promptly inform the Purchaser and the Project Manager in writing of any revision or alteration of such an organization chart.

3.23.2 The Contractor shall submit to the Purchaser for his approval the Program schedule in the form of **MS Project Network**, within fifteen(15) days of placement of LoA, with respect to Contract ,where such programme schedule is required, which shall, interalia, contain the following:

- a. the order in which the Contractor proposes to carry out the Works (including but not limited to design, engineering, manufacture, supply, finalization of Sub-contractors , Quality plans, transport, delivery to Site, assemble, erection, testing and commissioning),
- b. the date(s) by which the Contractor reasonably requires that the Purchaser shall have fulfilled its obligations under the Contract so as to enable the Contractor to execute the Contract in accordance with the Program and to achieve Completion and conductance of guarantee test of the Works in accordance with the Contract

c. the times of submission and approval of the Contractor's
Drawings

- 3.23.2.1. The Program so submitted by the Contractor shall be in accordance with the Time Schedule mentioned above and any other dates and periods specified in the Contract. The Contractor shall update and revise the Program as and when appropriate or when required by the Project Manager, but without modification in the Time for Completion of the milestone and any extension granted in accordance with GCC 3.46 and shall submit all such revisions to the Project Manager.
- 3.23.2.2. This Program shall show clearly all activities and its duration along with earliest and latest dates and the first and last dates of submission of the drawings and each date of shop inspection by the Purchaser and critical path for the Works. The Program approved by the Purchaser shall form part of the Contract.
- 3.23.2.3. The approval by the Purchaser of the Program shall not relieve the Contractor from any obligation under the Contract towards timely completion of Works.
- 3.23.2.4. Once the programme schedule has been finalized, no revision shall normally be permitted as long as the scope of work remains unchanged. However, in cases of increase in quantities, while executing the work as per original scope; suitable adjustments may be made without affecting the time for completion. The revision in programme schedule, for aforesaid reasons, shall be done with the approval the Purchaser.
- 3.23.2.5. If the scope of work undergoes changes during execution stage resulting into additional scope over that originally provided, for which the Contractor insists extension in time for completion, such extension shall be granted while ordering additional scope of work. Contractor shall submit revised programme schedule for approval of the Purchaser.
- 3.23.2.6. In case the scope of work does not change but the time for completion is extended because of delayed commencement of the work on account of non fulfilment of obligations by Purchaser or because of any other reasons not attributable to Contractor, programme schedule shall be suitably revised as per the extended time for completion. Once the time for completion has been extended with the approval of Purchaser, Contractor shall submit revised programme schedule for the approval of Purchaser.

3.23.3 Progress Report

The Contractor shall monitor progress of all the activities specified in the Program referred to in **GCC 3.23.2**, and supply a progress report to the Project Manager every month, with a copy to officials as mentioned in the SCC. Guarantee

- 2.23.3.1. The progress report shall be in a form acceptable to the Project Manager and shall also indicate: (a) percentage completion achieved compared with the planned percentage completion for each activity; and (b) where any activity is behind the Program, giving comments and likely consequences and stating the corrective action being taken.

3.23.4 Progress of Performance

If at any time the Contractor's actual progress falls behind the Program referred to in GCC 3.23.2, or it becomes apparent that it will so fall behind, the Contractor shall, at the request of the Purchaser or the Project Manager, prepare and submit to the Project Manager a revised Program, taking into account the prevailing circumstances, and shall notify the Project Manager of the steps being taken to expedite progress so as to attain Completion of the Works within the Time for Completion as stated in SCC, or within such extended time to which the Contractor shall be entitled under GCC 3.46.2

3.24. DESIGN AND ENGINEERING

- 3.24.1** The Contractor shall submit to the Purchaser for approval:

Within the time given in the Contract or in the Program such documents including drawings, samples, models or information as may be called for therein, and in the numbers therein required, in a sequential order of execution and during the progress of the Works, such documents of the general arrangement and details of the Works as specified in the Contract. The Purchaser shall signify his approval or disapproval as detailed in the schedule and procedure of documents approval indicated below.

- 3.24.2** The Contractor shall prepare (or cause its Sub-contractors to prepare) and furnish to the Project Manager the documents, including Manufacturing Quality Plan and Field Quality Plan wherever required or review as specified and as in accordance with the requirements of GCC 3.23.2.

- 3.24.3** Any part of the Works covered by or related to the documents to be approved by the Purchasers Representative shall be executed only

after the Project Manager's approval thereof

- 3.24.4** The Contractor shall supply additional copies of approved documents in the format and numbers stated in the Contract.
- 3.24.5** The Schedule and Procedure of Documents Approval shall be finalised at the **Kick off** meeting and also Contract Coordinate Procedure (**CCP**) shall be prepared.
- 3.24.6** If any dispute or difference occurs between the Purchaser and the Contractor in connection with or arising out of the disapproval by the Project Manager of any document and/or any modification(s) thereto that cannot be settled between the parties within a reasonable period, then such dispute or difference may be settled in accordance with **GCC 3.6.1** thereof.
- 3.24.7** The Project Manager's approval, with or without modification of the document furnished by the Contractor, shall not relieve the Contractor of any responsibility or liability imposed upon it by any provisions of the Contract except to the extent that any subsequent failure results from modifications required by the Project Manager.
- 3.24.8** Approval of any documents by the Purchaser shall not relieve the Contractor of his responsibility for the accuracy thereof or modification required during actual execution or for any deviation in scheme from Technical Specification with accepted deviations if there be any
- 3.24.9** **Approval of Design and Drawing:**
The contractor shall have to prepare and submit the designs and drawings associated with civil, mechanical, electrical and other work which includes design of foundation, structure cable sizing, fabrication work, layout design, wiring diagram etc. and obtain approval prior to the execution of work and for this purpose the contractor shall submit Detailed Design Report for obtaining approval from WBPDC. The contents of the Detailed Design Report shall be as mentioned in the scope of work (Clause no.GCC 3.24.10).
Materials: Contractor shall obtain prior approval for the materials deliverable under the project from WBPDC as mentioned in the technical specification.

3.24.10 Detailed Design Report (DDR)

Contractor shall prepare and submit the Detailed Design Report to WBPDCCL which must contain site meteorological data considered with necessary supporting documents, calculations for annual energy generation, schedule of site works(L1 & L2 network), Design of modules layout with Floaters and associated calculations for selection of different major equipments for the plant based on the site location and relevant code of practice.

The Detailed Design Report shall contain detailed Billing Breakup (BBU) for supply as well as Erection of Plant.

3.25. PROCUREMENT

3.25.1 The Contractor shall manufacture or procure and transport all the Equipment/Materials in an expeditious and orderly manner to the Site.

3.25.2 Defective Material

If in the opinion of the Engineer, any of the machineries/ equipment/ materials etc. brought to the site for use are not of the quality or kind specified in the contract and/or are unfit for the work, he shall be at liberty to order the removal of the said items and the contractor shall remove the same within twenty four (24) hours after notice has been given to him and if he fails to remove them within the time the engineer may cause them to be removed anywhere at the risk of the Contractor and any cost incurred in so doing shall be deducted from the dues to the contractor under the contract. In such case, items as prescribed by the Controlling Officer or his representative are to be substituted immediately.

3.25.3 Transportation.

3.25.3.1. The Contractor shall at its own risk and expense transport all the Equipment/Materials and the Contractor's Equipment to the Site by the mode of transport that the Contractor judges most suitable under all the circumstances

3.25.3.2. Unless otherwise provided in the Contract, the Contractor shall be entitled to select any safe mode of transport operated by any person to carry the Equipment/Materials and the Contractor's Equipment.

3.25.3.3. Upon dispatch of each shipment of the Equipment/ and the Contractor's Equipment, the Contractor shall notify the Purchaser by courier, email, post or by fax followed by post confirmation of the

description of the Equipment/Materials and of the Contractor's Equipment, the point and means of dispatch, and the estimated time and point of arrival at the Site. The Contractor shall furnish the Purchaser with relevant shipping documents to be agreed upon between the parties

3.25.3.4. The Contractor shall be responsible for obtaining, if necessary, approvals from the authorities for transportation of the Equipment/Materials and the Contractor's Equipment to the Site. The Purchaser shall use its best endeavours in a timely and expeditious manner to assist the Contractor in obtaining such approvals, if requested by the Contractor. The Contractor shall indemnify and hold harmless the Purchaser from and against any claim for damage to roads, bridges or any other traffic facilities that may be caused by the transport of the Equipment/ Materials and the Contractor's Equipment to the Site.

3.25.3.5. **Transit Damages:** In the event of receipt of goods in damaged condition or having found them so upon opening of packages at site, Contractor shall make good of all such damages within a reasonable time from such intimation by WBPDC.

3.26. CONTRACTOR'S CONSTRUCTION MANAGEMENT:

3.26.1 Setting Out

The Contractor shall be responsible for the true and proper setting-out of the Works in relation to bench marks, reference marks and lines provided to it in writing by or on behalf of the Purchaser.

The Contractor shall set out the Works in relation to original points, lines and levels of reference given by the Purchaser in writing and provide all necessary instruments, appliances and labour for such purposes. If at any time during the execution of Works, any error appears in the positions, levels, dimensions or alignment of the Works, the Contractor shall rectify the error at his cost. The checking of any setting-out by the Purchaser shall not relieve the Contractor of his responsibility for the accuracy thereof.

3.26.2 Contractor's Supervision

The Contractor shall give or provide all necessary superintendence during the installation of the Works, and the Contractor's representative(s) shall be constantly on the Site to provide full-time superintendence of the installation. The Contractor shall provide and employ only technical personnel who are skilled and experienced in

their respective callings and supervisory staff who are competent to adequately supervise the Works

3.26.3 Labour

3.26.3.1 The Contractor shall provide and employ on the Site in the installation of the Works such skilled, semi-skilled and unskilled labour as is necessary for the proper and timely execution of the Contract. The Contractor is encouraged to use local labour that has the necessary skills

3.26.3.2 Unless otherwise provided in the Contract, the Contractor shall be responsible for the recruitment, transportation, accommodation and catering of all labour, local or expatriate, required for the execution of the Contract and for all payments in connection therewith.

3.26.3.3 The Contractor shall be responsible for obtaining all necessary permit(s) and/or visa(s), if required, from the appropriate authorities for the entry of all labour and personnel to be employed on the Site.

3.26.3.4 The Contractor shall at its own expense provide the means of repatriation to all of its and its Sub-contractor's personnel, employed on the Contract, at the Site to their various home countries. It shall also provide suitable temporary maintenance of all such persons from the cessation of their employment on the Contract to the date programmed for their departure.

3.26.3.5 The Contractor shall at all times during the progress of the Contract use its best endeavours to prevent any unlawful, riotous or disorderly conduct or behaviour by or amongst its employees and the labour of its Sub-contractors.

3.26.3.6 The Contractor shall, in all dealings with its labour and the labour of its Sub-contractors currently employed on or connected with the Contract, pay due regard to all recognized festivals, official holidays, religious or other customs and all local laws and regulations pertaining to the employment of labour.

3.26.4 Contractor's Equipment

3.26.4.1 The Contractor shall provide all erection Equipment haulage & power if necessary to complete the Works as per Time for completion, including transport at his own cost. The Contractor shall provide additional manpower as well as haulage and other erection equipment as necessary for maintaining the Time schedule of completion.

3.26.4.2 Contractor's all equipment shall, when brought to the Site, be deemed to be exclusively intended for the execution of Contract. The Purchaser

shall have lien on all such Equipment brought to Site for the purpose of erection, testing and commissioning of the Equipment/Materials.

- 3.26.4.3 The Contractor shall not remove from the Site any such Equipment, except when it is no longer required for the completion of the Works, or when the Purchaser has given his consent.

3.26.5 Purchaser's Equipment

The Contractor shall pay hire charges as may reasonably be levied for the Purchaser's equipment, if used, and also provide the transport, haulage, power etc. thereof at his own cost.

3.26.6 Site Regulations and Safety

The Purchaser and the Contractor shall establish Site regulations setting out the rules to be observed in the execution of the Contract at the Site and shall comply therewith. The Contractor shall prepare and submit to the Purchaser, with a copy to the Project Manager, proposed Site regulations for the Purchaser's approval, for which approval shall not be unreasonably withheld.

Such Site regulations shall include, but shall not be limited to, rules in respect of security, safety of the Works, gate control, sanitation, medical care, and fire prevention. Details are mentioned in **SCC clause no.4.8.**

3.26.7 Environment & Social Policy and Procedures (ESPP) of Purchaser

The Contractor shall make himself aware of the ESPP of the Purchaser and shall execute the scope of work under the Contract in compliance with the said provisions.

3.26.8 Watching and Lighting

The Contractor shall provide and maintain at its own expense all lighting, fencing, and watching when and where necessary for the proper execution and the protection of the Works, or for the safety of the Purchasers and occupiers of adjacent property and for the safety of the public.

3.26.9 Clearance of Site

The Contractor shall, from time to time during the progress of the Works clear away and remove all surplus/ rejected materials and debris from Site. On completion of the Works, the Contractor shall remove all Contractors' Equipment and leave the whole of the Site clean and in a workmanlike condition to the satisfaction of the Purchaser.

3.26.10 Communication

The Contractor may require the Purchaser to confirm in writing any decision or instruction of the Purchaser which is not in writing. The Contractor shall promptly notify the Purchaser of such requirement.

3.26.11 Authority of Access

No persons other than the employees of the Contractor or his authorised representative shall be allowed at the Site. Purchaser or his representative shall have access to the work sites at any time.

3.26.12 Emergency work

3.26.12.1 If, by reason of an emergency arising in connection with and during the execution of the Contract, any protective or remedial work is necessary as a matter of urgency to prevent damage to the Works, the Contractor shall immediately carry out such work.

3.26.12.2 If the Contractor is unable or unwilling to do such work immediately, the Purchaser may do or cause such work to be done, as the Purchaser may determine it necessary in order to prevent damage to the Works. In such event the Purchaser shall, as soon as practicable after the occurrence of any such emergency, notify the Contractor in writing of such emergency, the work done and the reasons thereof. If the work done or caused to be done by the Purchaser is such that the Contractor was liable to do at its own expense under the Contract, the reasonable costs incurred by the Purchaser in connection therewith shall be paid by the Contractor to the Purchaser.

3.27. INSPECTION & TESTING

3.27.1 Inspecting Agency

The Purchaser may delegate inspection and testing to an outside agency in place of personnel of PURCHASER with due notice, not less than fifteen (15) days, to the Contractor. Any such outside agency shall be considered as a **Project Manager**

3.27.2 Inspection and Testing During Manufacture

3.27.2.1 The Purchaser or his designated representative shall be entitled during manufacture to inspect, examine and test the materials and workmanship and check the progress of manufacture of all Equipment to be supplied under the Contract. This shall take place on the Contractor's premises during working hours.

3.27.2.2 No such inspection, examination or testing shall relieve the Contractor of his obligation under the Contract regarding quality of material and soundness of manufacture.

3.27.2.3 No inspection call will be valid before drawings are approved under approval category without comments.

3.27.3 Dates for Inspection and Testing

After getting the related drawings approved under approval category, the Contractor shall give the Purchaser notice of inspection along with factory test results in writing of the date and the place at which any Equipment/Materials will be ready for testing as provided in the Contract. The Purchaser shall attend at the place so named within fifteen (15) days of the date which the Contractor has stated in his notice. The Purchaser shall give the Contractor notice, in writing, of his intention to attend the tests. The above notices shall be given at first by the quickest possible means and confirmed later in writing. The Contractor shall render all possible assistance in carrying out inspection in time

3.27.4 Facilities for Testing

3.27.4.1 Where the Contract provides for tests on the premises of the Contractor or Sub-contractor, the Contractor shall provide such assistance, labour, materials, electricity, fuel, stores, apparatus and instruments as may be necessary to carry out the tests efficiently without any extra charges. If the facilities are inadequate to carry out tests as per standard, the Contractor shall have to arrange suitable testing place having all such required facilities and the cost towards this will be on Contractor's account.

3.27.4.2 The Contractor shall also bear all charges towards travelling expenses for India or abroad (if any supply from outside of India) for Inspecting Team of the Purchaser or the authorized representatives of the Outside Inspecting Agency consisting of **maximum two (2) persons** for to and fro journey by Air from Purchaser's Head quarters, including boarding and lodging at the place of inspection and transit, if any, for the purpose of Inspection and testing.

3.27.4.3 The Contractor shall be responsible for proper execution of the quality plans. The Works beyond Purchaser's hold points will progress only with Purchaser's prior written consent. The Purchaser may also undertake quality surveillance and quality audit of the systems and procedures and quality control activities. Any change in the Quality Plans shall be made only with Purchaser's prior written approval.

3.27.4.4 The Contractor shall provide the Purchaser with the necessary facilities for carrying out quality audit and quality surveillance of the

Contractor's and its Sub-Contractors' Quality Assurance System and manufacturing activities

3.27.5 Routine and Acceptance Tests

All routine tests and acceptance tests shall be carried out at manufacturer's works or test site of the Contractor/Sub-contractor/test laboratory as per stipulation of relevant Indian Standard and relevant IEC in presence of Project Manager. All tests shall be carried out on every lot offered for inspection as per relevant I.S. and IEC.

3.27.6 Type Test

3.27.6.1 The successful bidder shall submit complete test reports of all tests (including type tests) as stipulated in the relevant I.S. and IEC and carried out in a Govt. recognized Test House or laboratory/NABL accredited laboratory on Equipment/ Materials of identical design conforming to our Technical Specification, along with submission of drawing during detailed engineering stage

3.27.6.2 PURCHASER may also undertake Proto checking and quality approval of structural items (wherever applicable) before erection. Each type test report shall provide the following information with test results:
Complete identification, date and Serial No.
Method of application where applied, duration and interpretation of each test.

3.27.7 Repetition of Tests

If any of the type tests, routine or acceptance tests fails to pass, the Contractor shall arrange for repetition of the tests, after rectification or replacement, at his own cost and expenses. If, however, the tests fail for the 2nd time, the related Sub-contractor shall be rejected immediately and the Contractor will be required to furnish the name of another Sub-contractor immediately either from the already approved list of Sub-contractor for that particular Equipment/Materials, or any new Sub-contractor along with submission of all relevant documents in support, towards approval of the new Sub-contractor as stated in this tender document.

3.27.8 Reports of Inspection and Tests

After the factory tests have been completed at the Contractor's or Sub-contractor's works, the Contractor shall submit **three (3) copies** of Test Reports for approval of Purchaser. The Purchaser in turn will approve the same. The Contractor shall provide the Purchaser with

four (04) copies of Approved Reports of all inspection and tests.

3.27.9 If the Purchaser or his designated representatives fails to attend the test and/or inspection or if it is agreed between the parties that such persons shall not do so, then the Purchaser may advise the Contractor in writing to proceed with the test and/or inspection in the absence of such persons. The Contractor should provide the Purchaser with a certified report of the results thereof.

3.27.10 Covering Up

3.27.10.1 The Contractor shall give the Purchaser full opportunity to examine, measure and test any work on Site which is about to be covered up or put out of view.

3.27.10.2 The Contractor shall give due notice to the Purchaser whenever such work is ready for examination, measurement or testing.

3.27.10.3 The Purchaser shall then notify the Contractor within **fifteen (15) days** that the Purchaser shall carry out the examination, measurement or testing. Unless it is notified specifically the Contractor may proceed with the work as per Programme submitted.

3.27.11 Uncovering Works

If so instructed by the Purchaser, the Contractor shall expose any parts of the Works. The Contractor shall reinstate and make good such parts to the Purchaser's satisfaction at the risk, cost and responsibility of the Contractor

3.28. TESTS ON COMPLETION.

3.28.1 Notice for Tests on Completion

The Contractor shall give to the Purchaser twenty one (21) days notice of the date after which he will be ready to conduct the Tests on Completion. Unless otherwise agreed upon, the Tests shall be carried out as per agreed schedule.

3.28.2 Delayed Tests

If the tests are being unduly delayed by the Contractor, the Purchaser may, by notice, require the Contractor to make the tests within twenty one (21) days after the receipt of such notice. If the Contractor fails to make the tests within twenty one (21) days of such notice, the Purchaser may himself proceed with the tests. All tests so made by the Purchaser shall be at the risk and cost of the Contractor and cost thereof shall be deducted from the Contract Price. The tests shall also be deemed to have been made in the presence of the Contractor and

shall be accepted as accurate and no claim whatsoever in this respect of the Contractor shall be entertained.

3.28.3 Facilities for Tests on Completion

The Contractor, except where otherwise specified, shall arrange such labour, material, fuel, water, stores and testing apparatus as may be reasonably required to carry out such tests efficiently, without any extra charge

3.28.4 Re-testing

If the work or any portion thereof fails to pass the Tests, the Purchaser or the Contractor may require such tests to be repeated on the same terms and conditions. All costs of such retesting will be borne by the Contractor.

3.28.5 Consequences of Failure to Pass Tests on Completion

If the Works or any portion thereof fails to pass the tests or the repetition thereof under GCC.28, the Purchaser, after due consultation with the Contractor, shall be entitled to

Order one further repetition of the Tests under the conditions of GCC 3.26, or

Reject the Works or portion thereof in which event the Purchaser shall have the same remedies against the Contractor as are provided under GCC 3.27 or

Issue a Taking-Over Certificate, if the Purchaser so wishes, notwithstanding that the Works are not complete. The Contract Price shall then be reduced by such amount as may be agreed by the Purchaser and the Contractor or, failing agreement, as may be determined under GCC 3.6. As soon as the work or any portion thereof has passed the tests, the Purchaser shall issue a Completion certificate to the Contractor to that effect.

3.29. REJECTION

Purchaser may not accord approval to test results if those results are not in conformity with Guaranteed Technical Particulars with given tolerable limits as per relevant standard or the results and procedure followed are found not in line with standard. The results may be rejected even if the Project Manager had witnessed the test. On approval of Test results only, Material Inspection Clearance Certificate will be issued by the Purchaser. Approval of Test results will not relieve the Contractor of its obligation as regards quality, standard and suitability of the Equipment/ Materials.

3.30. PERMISSION TO DELIVER

3.30.1 The Contractor shall apply in writing to the Purchaser for permission to deliver any Equipment / Materials to the Site. No Equipment/ Materials shall be delivered to the Site without the Purchaser's written permission

3.30.2 The Contractor shall make arrangement for receipt of all Equipment/ Materials delivered to Site under the scope of Contract besides all other Equipment/Materials required for the purpose of execution. Upon arrival at Site, the Contractor shall give a notice to the Purchaser when and where materials has arrived and been stored.

3.31. COMPLETION OF WORKS

3.31.1 As soon as execution of the Works or any part for which a separate completion schedule is provided in the Contract has, in the opinion of the Contractor, been completed operationally and structurally and put in tight and clean condition as specified in the Technical Specifications, excluding minor items not materially affecting the operation or safety of the Works, the Contractor shall so notify the Purchaser in writing within **seven (7) days** of the date of completion.

3.31.2 If, for reasons not attributable to the Contractor, the Works cannot be completed in next six (6) months, the Purchaser at, its discretion, may take up the inspection of the portion of the Works already completed, the balance payment due to the Contractor can be released against Bank Guarantee of equivalent amount. The Bank Guarantee validity shall be initially for a period of twelve (12) months or until three (3) months after expected date of commissioning, whichever is earlier. If the completion and thereafter commissioning does not take place within the validity period of the Bank Guarantee, the validity shall be extended from time to time up to a period not exceeding three(3) years from the date from which the concerned work was held up on aforesaid account. The Contractor shall also be required to extend the validity of the Contract Performance Guarantee.

3.31.3 For 'Works' not involving Commissioning

3.31.3.1 Within **fifteen (15) days** of intimation from the Contractor regarding completion of Works, the Project Manager shall cause to inspect the Works to verify the completion status, in presence of the Contractor's representative.

3.31.3.2 If the Works are found to be completed and acceptable in all respects (except for minor defects and deficiencies, if any), Completion Certificate (**Annexure-6**) / Taking over Certificate (TOC) shall be

issued by the Purchaser after the Contractor's intimation. The Completion certificate shall generally contain the following details: (a) Date of completion; (b) Defects to be rectified; (c) Items not conforming to Specification but can be accepted at a reduced rate; (d) items not acceptable at all and need to be re-done

3.31.3.3 If, on inspection, Works are not found to be completed or rectification of major nature is required, the Purchaser shall, within twenty-one (21) days of Contractor's intimation, inform the incomplete works/ defects & deficiencies to the Contractor in writing advising him to take necessary action and to inform PURCHASER after completion/ rectification. The Purchaser shall give reasonable time to the Contractor for remedying the defects/ deficiencies. However, if the Contract specifies separate completion period for different parts of works for the purpose of taking over also, Completion certificate/ TOC shall be issued in respect of portion of works that are completed and are acceptable.

3.31.3.4 The provisions contained in GCC 3.31.3.1 to GCC 3.31.3.3 shall also be applicable in relation to a part of the Works for which separate schedule of completion has been provided in the Contract and such part of Works can be taken over independently

3.32. TAKING OVER

3.32.1 The Works shall be taken over by the Purchaser after completion, either in full or in part (where for part completion, separate completion schedule has been provided in the Contract), upon successful erection, testing and commissioning of Works at Site by the Contractor in accordance with provisions of Contract.

3.32.2 On successful completion of Works or any part thereof as provided in GCC 3.32.1 and upon request of the Contractor for taking over the Works and issuance of TOC, the Purchaser shall, within forty-five (45) days after the receipt of the Contractor's application, or within fifteen (15) days from the date of actual handing over of relevant Works, either issue the TOC or reject the application giving his reasons and specifying the work required to be done by the Contractor to enable the TOC to be issued

3.32.3 TOC is issued to the Contractor on stating the date on which the Works or any part thereof were complete and ready for taking over, after ascertaining the following:

- a. The Works under the Contract have been satisfactorily completed by the Contractor as per the provisions of Contract.
- b. Submission of required number of reproducible of approved as-built drawings (hard copies & soft copy in CDs), design documents duly authenticated by Purchaser, O&M manuals, data sheets, test reports, pamphlets and manuals of spares, maintenance and testing equipment by the Contractor.
- c. The Contractor has cleared the Site of all the surplus materials, removed all scaffoldings, shuttering materials, labour huts/sheds, cleaned the dirt from part of building, sanitary arrangement, water supply connection and all electrical gadgets/equipments/ switches, wiring, any wood work or any such item, to the satisfaction of the Project Manager, except those required for carrying out rectification works.
- d. All the defects have been rectified to the complete satisfaction of the Project Manager

3.32.4 Issuance of such certificates shall not relieve the Contractor of any of his obligations which otherwise comes under the terms and conditions of the Contract.

3.32.5 Notwithstanding the above mentioned provisions, the issuance of TOC shall not be held up for delay in completion/ rectification of works of minor nature that do not affect the performance/ use of the building/installation/ equipment/sub-system/system at rated voltage. In such a case the Contractor shall however be required to give an undertaking that in case he fails to complete/rectify within a mutually agreed period, the Purchaser shall be at liberty to carry out the work at his risk and cost, and deduct an amount as may be considered appropriate by the Purchaser.

3.32.6 Issuance of TOC for any part of the Works is only for the purpose of facilitating the Contractor to receive the payment for part of the Works completed and for determination of liquidated damages in respect thereof and shall not relieve the Contractor of his responsibilities under the Contract towards other parts of the Works.

F. GUARANTEES AND LIABILITIES

3.33. NET MINIMUM GUARANTEED GENERATION (NMGG)

Contractor shall have to ensure Net Minimum Guaranteed Generation @ 1.52 MU/MWp for the first year after final commissioning and at a reduced rate of 1% per year for subsequent years. Initially, the above Guarantee shall be required for the 5 years i.e. in the O&M period. The same guarantee shall continue for extended O & M period, if agreed on mutual terms & conditions. The Contractor shall design their plant to achieve the Net Minimum Guaranteed Generation.

The Generated energy will be measured at the Outgoing feeder of the Solar PV Power Plant i.e. the Net Minimum Guaranteed Generation will be calculated without considering the Auxiliary Load.

The bidder shall submit a declaration for the Net Minimum Guaranteed Generation with their bid (Form-13). Non-submission of the document will entail for disqualification of the bidder.

3.34. LIQUIDATED DAMAGES (LD)

3.34.1 LD for Time Delay:

Compensation of loss on account of late delivery/completion (notionally/actually) where loss is pre-estimated and mutually agreed to is termed as LD. Law allows recovery of pre-estimated loss provided such a term is included in the contract and there is no need to establish actual loss due to late supply/execution of work. Time schedule of delivery/completion shall be essence of the order. If the contractor fails to execute the order in full or part thereof within the fixed period or any time repudiate the contract before the expiry of such period, the Corporation may, without prejudice to any other right or remedy available, recover damages for breach of contract and to safe-guard its interest.

'In the event of any delay in the supplies of ordered materials/execution of works beyond the stipulated delivery/completion schedule including any extension permitted in writing, the Corporation reserves the right to recover from the contractor a sum equivalent to 0.5% of the value of delayed supply/work for each week of delay and part thereof subject to a maximum of 10% of the total value of order.'

3.34.2 LD for Milestone Delay

Delay in attaining the milestones by the contractor shall lead to imposition of intermediary Liquidated damages @0.25% per week of delay upto the maximum extent of 5(Five) Percent of the Contract price.

Intermediary Liquidated damages shall be calculated based on the following Milestones.

Sl. No.	Description	Completion Time	% of LD
1.	Approval of Detailed Design Report	65 Days	0.5
2.	Finalizations of Plant layout (including Modules, cable routes, inverter Control Room)	3 Months	1
3.	Completion of Supply of Floaters & Modules	9 Months	1.5
4.	Completion of construction of Inverter Control Room	10 Months	1
5.	Completion of Modules & Electrical Equipment Erection	11Month	0.5
6.	Completion of charging	12 Moths	0.5

3.34.3 The total/aggregate LD (LD for Time Delay + LD for Milestone Delay) leviable for this contract shall not exceed 15(Fifteen) Percent of the Contract price.

However no LD for milestone delay will be charged if the project is completed within the stipulated time provided such milestone delay does not hamper scheduled execution of any other related projects/activities thereby causing loss or damage to the Purchaser

3.35. DEFECTS LIABILITY

3.35.1 The Contractor warrants that the Works or any part thereof shall be free from defects in the design, engineering, materials and workmanship of the Equipment/Materials supplied and of the work executed.

- 3.35.2** The Defect Liability Period shall be as specified in the SCC. Where any part of the Works is taken over separately, the Defects Liability Period for that part shall commence on the date it was taken over.
- 3.35.3** If during the Defect Liability Period any defect should be found in the design, engineering, materials and workmanship of the Equipment/Materials supplied or of the work executed by the Contractor, the Contractor shall promptly, in consultation and agreement with the Purchaser regarding appropriate remedying of the defects, and at its cost, repair, replace or otherwise make good (as the Contractor shall, at its discretion, determine) such defect as well as any damage to the Works caused by such defect.
- 3.35.4** The Contractor shall not be responsible for the repair, replacement or making good of any defect or of any damage to the Works arising out of or resulting from any of the following causes:
- a. improper operation or maintenance of the Works by the Purchaser
 - b. operation of the Works outside Specifications provided in the Contract
 - c. normal wear and tear
- 3.35.5** Contractor's obligations under this Clause GCC 3.35.1 shall not apply to:
- a. any materials that are normally consumed in operation, or have a normal life shorter than the Defect Liability Period stated herein
 - b. any designs, Specifications or other data designed, supplied or specified by or on behalf of the Purchaser or any matters for which the Contractor has disclaimed responsibility herein
 - c. any other materials supplied or any other work executed by or on behalf of the Purchaser, except for the work executed by the Purchaser under GCC 3.35.9
- 3.35.6** The Purchaser shall give the Contractor a notice stating the nature of any such defect together with all available evidence thereof, promptly following the discovery thereof. The Purchaser shall afford all reasonable opportunity for the Contractor to inspect any such defect.
- 3.35.7** The Purchaser shall afford the Contractor all necessary access to the Works and the Site to enable the Contractor to perform its obligations under this Clause GCC 3.35. The Contractor may, with the consent of the Purchaser, remove from the Site any Equipment/Materials or any

part of the Works that are defective, if the nature of the defect and/or any damage to the Works caused by the defect is such that repairs cannot be expeditiously carried out at the Site

3.35.8 If the repair, replacement or making good is of such a nature that it may affect the efficiency of the Works or any part thereof, the Purchaser may give to the Contractor a notice requiring that tests of the defective part of the Works shall be made by the Contractor immediately upon completion of such remedial work, whereupon the Contractor shall carry out such tests.

If such part fails the tests, the Contractor shall carry out further repair, replacement or making good (as the case may be) until that part of the Works passes such tests. The tests, in character, shall in any case be not inferior to what has already been agreed upon by the Purchaser and the Contractor for the original part of the Works.

3.35.9 If the Contractor fails to commence the work necessary to remedy such defect or any damage to the Works caused by such defect within a reasonable time (which shall in no event be considered to be less than fifteen (15) days), the Purchaser may, following notice to the Contractor, proceed to do such work, and the reasonable costs incurred by the Purchaser in connection therewith shall be paid to the Purchaser by the Contractor or may be deducted by the Purchaser from any money due to the Contractor or claimed under the Performance Securities.

3.35.10 If the Works or any part thereof cannot be used by reason of such defect and/or making good of such defect, the Defect Liability Period of the Works or such part, as the case may be, shall be extended by a period equal to the period during which the Works or such part cannot be used by the Purchaser because of any of the aforesaid reasons.

At the end of the Defect Liability Period, the Contractor's liability ceases except for latent defects. The Contractor's liability for latent defects warranty for the Equipment/Materials, including spares, shall be limited to a period of five (5) years from the end of Defect Liability Period of the respective Equipment/Materials, including spares. For the purpose of this clause, the latent defects shall be the defects inherently lying within the material or arising out of design deficiency which do not manifest themselves during the Defect Liability Period as defined in this Clause GCC 3.35 but later.

3.35.11 Except as provided in Clauses GCC 3.35 and GCC 3.40, the

Contractor shall be under no liability whatsoever and howsoever arising, and whether under the Contract or at law, in respect of defects in the Works or any part thereof, the Equipment/Materials, design or engineering or work executed that appear after Completion of the Works or any part thereof, except where such defects are the result of the gross negligence, fraud, criminal or wilful action of the Contractor

3.35.12 In addition, the Contractor shall also provide an extended warranty for any such component of the Works and for the period of time as may be specified in the SCC. Such obligation shall be in addition to the defect liability specified under GCC 3.35.2

3.35.13 Defects Liability Certificate and No-Claim Certificate

When the Defects Liability Period for the Works or any part thereof has expired and the Contractor has fulfilled all his obligations under the Contract for defects in the Works or the part, the Purchaser shall issue to the Contractor a Defects Liability Certificate to that effect within next twenty-eight (28) days. A No-Claim Certificate should be furnished by the Contractor for contract closure before the issuance of the final Defects Liability Certificate by the Purchaser. Such No-claim certificate shall be furnished by the Contractor as per Annexure of Section VIII. The Contractor is expected to complete all formalities for closure of Contract including their final claims relating to the Contract. All claims will be deemed to be settled and no further claims of the Contractor will be entertained after the furnishing of the No-Claim Certificate by the Contractor.

3.36. LIMITATIONS OF LIABILITY

3.36.1 Liability after Expiry of Defects Liability Period

The Contractor shall have no liability to the Purchaser for any loss of or damage to the Purchaser's physical property which occurs after the expiry of the Defects Liability Period unless caused by Gross Misconduct of the Contractor provided that this exclusion shall not apply to any obligation of the Contractor to pay Liquidated Damage to the Purchaser.

The aggregated liability of the Contractor to the Purchaser under the Contract shall not exceed the Contract Price provided that this limitation shall not apply to any obligation of the Contractor to the cost of repairing or replacing the defective Equipment/ Materials or to indemnify the Purchaser with respect to patent infringement

3.36.2 Mitigation of Loss or Damage

In all cases the party claiming a breach of Contract or a right to be indemnified in accordance with the Contract shall be obliged to take all reasonable measures to mitigate the loss or damage which has occurred or may occur

G. RISK DISTRIBUTION

3.37. TRANSFER OF PURCHASERSHIP

3.37.1 Purchasership of the Equipment/Materials (including spare parts) procured from within/outside the country shall be transferred to the Purchaser when the Equipment/Materials (including spare parts) are loaded on to the mode of transport to be used to convey the Equipment/Materials (including spare parts) from the works to the Site and upon endorsement of the dispatch documents in favour of the Purchaser.

3.37.2 Purchasership of the Contractor's Equipment used by the Contractor and its Sub-Contractors in connection with the Contract shall remain with the Contractor or its Sub-contractors.

3.37.3 Notwithstanding the transfer of Purchasership of the Equipment/Materials, the responsibility for care and custody thereof together with the risk of loss or damage thereto shall remain with the Contractor pursuant to GCC 3.39 hereof until Completion of the Works or the part thereof in which such Equipment/Materials are incorporated.

3.37.4 Indemnity by Contractors: As this is a turnkey project and the contractor is fully responsible for handling, erection and commissioning of the equipments and materials so for executing the work, the Contractor shall execute an Indemnity Bond in favour of the Purchaser for keeping the equipment in safe custody and to utilize the same exclusively for the purpose of the said Contract. The Indemnity Bond shall be furnished as per proforma in **Annexure-5** of Section VII. The Purchaser shall also issue a separate Authorization Letter to the Contractor to enable him to take physical delivery of Equipment/Materials from the Purchaser as per proforma enclosed in **Annexure-11** of Section VII.

3.37.5 After material reached at site contractor shall apply for gate pass to enter the material as per the **Annexure-10B** in the Purchser's site. The Materials reached at site will be in the custodian of the

Contractor.

- 3.37.6** The Purchaser will issue a Materials Receipt Certificate (MRC) as per **Annexure-12** after receiving the materials and equipments at site.

3.38. RISK AND RESPONSIBILITY

3.38.1 Allocation of Risk and Responsibility

The Risks of loss of damage to physical property and of death and personal injury which arise in consequence of the performance of the Contract shall be allocated between the Purchaser and the Contractor as follows

- a. the Purchaser: the Purchaser's Risks as specified in GCC 3.38.2
- b. the Contractor's Risks as specified in GCC 3.38.3

3.38.2 Purchaser's Risks

- a. War and hostilities (whether war be declared or not), invasion, act of foreign enemies,
- b. revolution, insurrection, military or usurped power or civil war,
- c. use or occupation of the Works or any part thereof by the Purchaser,
- d. the use or occupation of the Site or any part thereof, for the purposes of the Contract, or interference, whether temporary or permanent with any right-of-way, any easement, way leave or right of a similar nature which is inevitable result of the construction of the Works in accordance with the Contract.
- e. the right of the Purchaser to construct the Works or any part thereof on, over, under, in or through any land,
- f. damage (other than that resulting from the Contractor's method of construction) which is the inevitable result of the construction of the Works in accordance with the Contract,
- g. the act, neglect or commission or breach of Contract or of statutory duty of the Purchaser

3.38.3 Contractor's Risks

The Contractor's Risks are all risks other than those identified as the Purchaser's Risks.

3.39. CARE OF WORKS

3.39.1 Contractor's Responsibility for the care of Works, man and Materials/Equipments

The Contractor shall be responsible for the care of Works, man and materials/equipments from the Commencement Date until the Risk

Transfer Date applicable thereto under GCC 3.39.2

3.39.2 Risk Transfer Date

The Risk Transfer Date in relation to the Works is the date of occurrence of any of the following

- a. the date of issue of the TOC, or
- b. the date of expiry of the notice of termination when the Contract is terminated by the Purchaser or the Contractor in accordance with these Conditions

The risk of loss or damage to the Works shall pass from the Contractor to the Purchaser on the Risk Transfer date applicable thereto.

3.39.3 Making Good the Damage

3.39.3.1 After risk transfer date

To making good forthwith loss or damage caused by the Contractor prior to the completion of the Defects Liability period

3.39.4 Till such time the system is not commissioned or taken over by PURCHASER, its custody and watch and ward shall remain with Contractor who shall accordingly be required to maintain a skeleton establishment at Site. Charges towards insurance cover for Contractor supplied Equipment /Material shall be paid by the Contractor till completion of the defect liability period.

3.40. ACCIDENT OF INJURY

Damage to property and injury to persons, accident or injury to workers

3.40.1 Contractor's liability

Except as provided under GCC 3.43 the Contractor shall be liable for and shall indemnify the Purchaser against all losses, expenses and claims in respect of any loss of or damage to physical property (other than Works), death or personal injury to the extent caused by :

- a. defective design, material or workmanship of the Contractor, or
- b. negligence or breach of statutory duty of the Contractor, his Sub-contractors or their respective employees and agents

3.40.2 Accidents

The Contractor shall be liable for and shall indemnify the Purchaser against all losses, expenses or claim arising in connection with the

death of or injury to any person employed by the Contractor or his Sub-contractors for the purposes of the Works.

The Contractor/Sub-contractor shall obtain necessary insurance coverage under the Employees compensation Act-1923 to cover the risk of payment of compensation in case of injury/death arising in course and out of employment to any employee.

3.41. INSURANCE

3.41.1 The Contractor at his own cost shall arrange, secure and maintain all insurances as may be pertinent to the Works and obligatory in terms of law to protect his interest and interests of the Purchaser against all perils detailed herein in the type and up to the limit of such insurance as defined herein together with the underwriter in each case shall be acceptable to the Purchaser. The identity of insurers and the form of policies shall be subject to the approval of Purchaser which shall not be unreasonably withheld. However, irrespective of such acceptance, the responsibility to maintain adequate insurance coverage at all times during the period of Contract including the extended period of Contract shall be of Contractor alone.

3.41.2 Any loss or damage to the Equipment/ Materials during transportation, handling, storage, erection, putting into satisfactory operation and all activities to be performed till the successful completion of commissioning of the Equipment and handed over to the Purchaser shall be to the account of the Contractor. The Contractor shall be responsible for preference of all claims and make good the damages or loss by way of repairs and/or replacement of the Equipment/ Materials, damaged or lost. The transfer of title shall not in any way relieve the Contractor of the above responsibilities during the period of Contract. The Contractor shall provide the Purchaser with copy of all insurance policies and documents taken out by him in pursuance of the Contract. Such copies of documents shall be submitted to the Purchaser immediately after such insurance coverage. The Contractor shall also inform the Purchaser in writing at least sixty (60) days in advance regarding the expiry/cancellation and/or change in any of such documents and ensure revitalization, renewal etc. as may be necessary well in time at his cost, risk and responsibility.

3.41.3 The perils required to be covered under the insurance shall include, but not be limited to fire and allied risks, miscellaneous accidents (erection risks), workman compensation risks, loss or damage in transit, theft, pilferage, riot and strikes and malicious damages, civil commotion, weather conditions, accidents of all kinds, terrorist attacks, war risks etc. The scope of such insurance shall be adequate to cover the replacement/ reinstatement cost of the Equipment/Materials for all risks up to and including delivery of goods on ex-works basis and shall also cover transportation and other costs till the Equipment/ Materials are delivered, erected and installed. Notwithstanding the extent of insurance cover and the amount of claim available from the underwriters, the Contractor shall be liable to make good the full replacement/ rectification value of all Equipment/Materials and to ensure their availability as per project requirements at its cost.

3.41.4 The Contractor shall ensure that for all activities to be performed under the Contract viz. transportation, storage, erection, testing, commissioning etc. till the Works are handed over to the Purchaser; the insurance cover shall only be taken from Indian Insurance Companies.

3.42. CHANGE IN LAWS AND REGULATIONS

If, after the date seven (7) days prior to the last date of bid submission, in the country where the Site is located, any law, regulation, ordinance, order or bye-law having the force of law is enacted, promulgated, abrogated or changed (which shall be deemed to include any change in interpretation or application by the competent authorities) that subsequently affects the costs and expenses of the Contractor and/or the Time for Completion, the Contract Price shall be correspondingly increased or decreased, and/or the Time for Completion shall be reasonably adjusted to the extent that the Contractor has thereby been affected in the performance of any of its obligations under the Contract. However, these adjustments would be restricted to direct transactions between the Purchaser and the Contractor and shall also not be applicable on the bought out items despatched directly by Sub-contractor(s) to Site. Notwithstanding the foregoing, such additional or reduced costs shall not be separately paid or credited if the same has already been

accounted for in the price adjustment provisions where applicable.

3.43. FORCE MAJEURE

- 3.43.1** “Force Majeure” shall mean any event beyond the reasonable control of the Employer or of the Contractor, as the case may be, and which is unavoidable notwithstanding the reasonable care of the party affected.
- 3.43.2** In the event of either party being rendered unable by Force Majeure to perform any obligation required to be performed by them under this contract, relative obligation of the party affected by such Force Majeure shall be treated suspended during which the Force Majeure clause last.
- 3.43.3** The term “Force Majeure” shall herein mean riots (other than among the contractor’s employee), Civil commotion, War (whether declared or not), invasion, act of foreign enemies hostilities, civil war, rebellion, revolution, insurrection, military coup, damage from aircraft, embargoes, quarantines, acts of god such as earthquake, floods, fires not caused by Contractor’s negligence and other causes which the Contractor has no control. Normal climatic conditions such as rainy season, monsoons, storms, etc. are not to be considered as Force Majeure.
- 3.43.4** Upon occurrence of such causes, the party claiming that it has been rendered unable as aforesaid, thereby, shall notify the other party in writing by registered notice within 10 (ten) days of the beginning of the event, thereof giving full particulars and satisfactory evidence in support of its claim.
- 3.43.5** The burden of proof as to occurrence of the event of Force Majeure and its effect shall be upon the party claiming the Force Majeure event and such claim shall be supported by documentary evidence in the form of a Certificate issued by a recognised chamber of Commerce or any other local, state or national authority.
- 3.43.6** Time for Performance of the relative obligation suspended by the event of force majeure shall stand extended by the period for which such clause lasts.
- 3.43.7** If works are suspended by Force Majeure conditions lasting for more than two months leading to prolonged force majeure, the parties shall hold consultation to find solution / resolve the problem satisfactorily.

Provided, the Employer shall reserve the right to cancel the Order / contract, wholly or partly, in order to meet the overall project schedule and make alternative arrangement for completion of delivery and other schedules.

- 3.43.8** The Contractor shall not claim any compensation for Force Majeure conditions and shall take appropriate steps to insure men and materials utilized by it under the Contract well in advance.

3.44. WAR RISKS

- 3.44.1** War risks shall mean any of the following events occurring or existing in or near India:

- a. war, hostilities or warlike operations (whether a state of war is declared or not), invasion, act of foreign enemy and civil war
- b. rebellion, revolution, insurrection, mutiny, usurpation of civil or military government, conspiracy, riot, civil commotion and terrorist acts, and
- c. any explosion or impact of any mine, bomb, shell, grenade or other projectile, missile, munitions or explosive of war

- 3.44.2** Notwithstanding anything contained in the Contract, each party to the Contract shall bear its own costs for any loss or damages as may be incurred on accounts of war risks with respect to:

- a. destruction of or damage to Works or any part thereof to the extent not taken over by the Purchaser shall be the Contractor's risk and for those taken over by the Purchaser, it shall be the Purchaser's risk.
- b. injury or loss of life of its personnel

H. CHANGE IN CONTRACT ELEMENTS

3.45. VARIATIONS

3.45.1 Changes originating from Purchaser

The Purchaser may, by variation order to the Contractor, at any time before the Works are taken over, instruct the Contractor to alter, amend, omit, add to or otherwise vary any part of the Works. The Contractor shall not vary or alter any of the Works, except in accordance with a variation order from the Purchaser. The Contractor may, however, at any time propose variations of the Works to the Purchaser.

The Contractor shall not request for extension of time for completion in case of variation of quantity during execution for an increase as

specified in SCC.

3.45.2 Variation order procedure

Prior to any variation order under **GCC. 3.44.1** the Purchaser shall notify the Contractor of the nature and form of such variation. As soon as possible after having received such notice, the Contractor shall submit to the Purchaser:

- a. A description of Works, if any, to be performed, its anticipated quantity, the proposed rate in case of a new item and total adjustment to the Contract Price. In case of items for which the rates are available in the Contract the extra quantities shall be executed by the Contractor at the same rates upto the variation limit provided in the Contract.
- b. The Contractor's proposals for any necessary modifications to the Program according to **GCC 3.23** or to any of the Contractor's obligations under the Contract.

3.45.3 Following the receipt of the Contractor's submission, the Purchaser shall, after due consultation with the Contractor, decide whether or not the variation shall be carried out.

3.45.3.1 If the Purchaser decides that the variation shall be carried out, he shall issue a variation order clearly identified as such in accordance with the Contractor's submission or as modified by mutual agreement.

3.45.3.2 Pending issue of variation order, the Purchaser may require the Contractor to proceed ahead with the Works to avoid delay in the progress of Works. In such situations, subject to physical verification, payment shall be made up to sixty percent (60%) of rates as provided in the Contract, for items for which separate rates are available beyond prescribed limit of quantity variation as per the Contract.

3.45.3.3 In case of new items/ substituted items, up to forty (40%) of amount estimated by the Purchaser shall be paid to the Contractor subject to reasonableness of the claim. If the Purchaser and the Contractor are unable to agree to the adjustment of the Contract Price, the provisions of **GCC 3.45.4** shall apply.

3.45.4 Disagreement on adjustment of the Contract Price

3.45.4.1 If the Contractor and the Purchaser are unable to agree on the adjustment of the Contract price, the adjustment shall be determined in accordance with the rates specified in the approved

Price Schedules (BBU), subject to ceiling in Contract Price variation as specified in SCC.

3.45.4.2 If the rates contained in the Price Schedules are not directly applicable to the specific Works in question, suitable rates shall be established by the Purchaser reflecting the level of pricing in the Price Schedules.

3.45.4.3 Where rates are not contained in the said Price Schedule, for the sake of reaching a reasonable rate in respect of any sort of erection work, the number of skilled, semi-skilled and unskilled labour and minimum wage rate declared by the Govt. of West Bengal and/or the rates specified on the latest PWD/CPWD Schedule, overhead, profit and consumables shall be the basis for determination of reasonable rate.

3.45.4.4 For any supply item, reasonable rates shall be reached based on current purchase rate of identical equipment purchased by PURCHASER. The Contractor shall also be entitled to be paid:

the cost of any partial execution of the Works rendered useless by any such variation, and

The cost of making necessary alterations to Equipment already manufactured or in the course of manufacture or of any work done that has to be altered in consequence of such a variation.

The Purchaser shall on this basis determine the rates or prices to enable on account payment to be included in certificates of payment.

3.45.5 Contractor to Proceed

On receipt of a variation order, the Contractor shall forthwith proceed to carry out the variation and be bound to these conditions in so doing as if such variation was stated in the Contract. The Works shall not be delayed pending the granting of an extension of the Time for Completion or an adjustment to the Contract Price under **GCC 3.45.4**.

3.45.6 Records of costs

In any case where the Contractor is instructed to proceed with a variation prior to the determination of the adjustment to the Contract Price, keeping in mind that the adjustment of Contract Price due to this variation shall be guided by **GCC 3.45.4** the Contractor shall keep the necessary records of the cost of undertaking the variation and of time expended thereon. Such records shall be open to inspection/ verification by the Purchaser at

all reasonable times.

3.45.7 Quantity variation

PURCHASER, during execution of the Contract, reserves the right to increase or decrease the quantity of goods and services for the items included in the Contract with variation of the total Contract Price as specified in SCC but without any change in unit price or other terms and conditions. The quantity of the individual items of goods and services may however vary up to any extent within the overall ceiling limit of the Contract Price.

3.46. EXTENSION OF TIME FOR COMPLETION

3.46.1 Delivery and installation of Equipment/Materials as per requirement of work Program shall be made by the Contractor in accordance with Time Schedule pursuant to the SCC or within such extended time to which the Contractor shall be entitled under **GCC 3.46.2**

3.46.2 Reasons for Extension of Time for Completion

The Contractor may seek an extension of the Time for Completion if he is or will be delayed in completing the Works by any of the following reasons:

- a. extra or additional work ordered in writing under GCC 3.45.
- b. the delay in completion of Works caused for no fault on the part of the Contractor due to orders/instructions issued by the Purchaser
- c. Force Majeure as per GCC 3.43.
- d. any changes in laws and regulations as provided in GCC 3.42.
- e. any other matter specifically mentioned in the Contract

3.46.3 The Contractor shall give notice to the Purchaser of his intention to make a claim for an extension of time within fifteen (15) days of the occurrence of any of the above cause(s). The notice shall be followed as soon as possible by the claim with full supporting details.

3.46.4 The Contractor shall demonstrate to the Purchaser's satisfaction that it has used its best endeavour to avoid or overcome such causes for delay and the parties will mutually agree upon remedies to mitigate or overcome causes for such delays.

3.46.5 Notwithstanding the provisions of clause **GCC 3.46.4**, the Contractor shall not be entitled to an extension of time for completion, unless the Contractor, at the time when circumstances specified in **GCC 3.46.2** arises, has immediately notified the Purchaser in writing that it may

claim such extension as caused by such circumstances. The Purchaser on receipt of such notice may agree to extend the Contract completion period as may be reasonable and mutually agreed but without prejudice to other terms and conditions of the Contract.

3.46.6 Earlier Completion:

The Purchaser may require completion of the Works or part thereof earlier than the Time for Completion, as mutually agreed between the Purchaser and the Contractor. The earlier completion date so agreed, if not achieved, shall not be considered for the purpose of levy of Liquidated damages.

3.47. TERMINATION

3.47.1 Termination for Purchaser's Convenience

3.47.1.1 The Purchaser may at any time terminate the Contract for any reason by giving the Contractor a notice of termination that refers to this sub-clause **GCC 3.47.1**.

3.47.1.2 Upon receipt of the notice of termination under **GCC 3.47.1.1**, the Contractor shall either immediately or upon the date specified in the notice of termination

- a. cease all further work, except for such work as the Purchaser may specify in the notice of termination for the sole purpose of protecting that part of the Works already completed, or any work required to leave the Site in a clean and safe condition
- b. terminate all subcontracts, except those to be assigned to the Purchaser pursuant to paragraph (d)(ii) of sub-clause GCC 3.47.2.
- c. remove all Contractor's Equipment from the Site, repatriate the Contractor's and its Sub-contractors' personnel from the Site, remove from the Site any wreckage, rubbish and debris of any kind, and leave the whole of the Site in a clean and safe condition
- d. In addition, the Contractor, subject to the payment specified in **GCC 3.47.3**, shall
 - i deliver to the Purchaser the parts of the Works executed by the Contractor up to the date of termination
 - ii to the extent legally possible, assign to the Purchaser all right, title and benefit of the Contractor to the Works as at the date of termination, and, as may be required by the Purchaser, in any subcontracts concluded between the

Contractor and its Sub-contractors

iii deliver to the Purchaser all non-proprietary drawings, Specifications and other documents prepared by the Contractor or its Sub-contractors as at the date of termination in connection with the Works

3.47.1.3 **Risk Purchase Clause:** In case of failure of supplier, WBPDCCL at its discretion may make purchase of the materials / services NOT supplied / rendered in time at the RISK & COST of the supplier. Under such situation, the supplier who fails to supply the goods in time shall be wholly liable to make good to WBPDCCL any loss due to risk purchase.

In case of items demanding services at site like erection and commissioning, vendor should send his servicemen /representatives within 7 days from the service call. In case a vendor fails to attend to the service call, WBPDCCL at its discretion may also make arrangements to attend such service by other parties at the RISK & COST of the supplier. Under such situation the supplier who fails to attend the service shall be wholly liable to make good to WBPDCCL any loss due to risk purchase / service including additional handling charges due to the change.

3.47.1.4 In the event of termination of the Contract under **GCC 3.47.1.1**, the Purchaser shall pay to the Contractor the following amounts:

- a. the Contract Price, properly attributable to the parts of the Works executed by the Contractor as of the date of termination
- b. the costs reasonably incurred by the Contractor in the removal of the Contractor's Equipment from the Site and in the repatriation of the Contractor's and its Sub-contractors' personnel
- c. any amounts to be paid by the Contractor to its Sub-contractors in connection with the termination of any sub-contracts, including any cancellation charges
- d. costs incurred by the Contractor in protecting the Works and leaving the Site in a clean and safe condition pursuant to paragraph (a) of **GCC. 3.47.1.2**

the cost of satisfying all other obligations, commitments and claims that the Contractor may in good faith have undertaken with third parties in connection with the Contract and that are not covered by paragraphs (a) through (d) above

3.47.2 Termination for Contractor's default

3.47.2.1 The Purchaser, without prejudice to any other rights or remedies it may possess, may terminate the Contract forthwith in the following circumstances by giving a notice of termination and its reasons thereof to the Contractor, referring to this **GCC 3.47**:

- a. if the Contractor becomes bankrupt or insolvent, has a receiving order issued against it, compounds with its creditors, or, if the Contractor is a corporation, a resolution is passed or order is made for its winding up (other than a voluntary liquidation for the purposes of amalgamation or reconstruction), a receiver is appointed over any part of its undertaking or assets, or if the Contractor takes or suffers any other analogous action in consequence of debt
- b. if the Contractor assigns or transfers the Contract or any right or interest therein in violation of **GCC. 3.48** if the Contractor, in the judgment of the Purchaser has engaged in corrupt or fraudulent practices in competing for or in executing the Contract

For the purpose of this Clause:

"corrupt practice" means the offering, giving, receiving or soliciting of anything of value to influence the action of a public official in the process or in Contract execution.

"fraudulent practice" means a misrepresentation of facts in order to influence a process or the execution of a Contract to the detriment of the Purchaser and includes collusive practice among bidders (prior to or after bid submission) designed to establish bid prices at artificial non-competitive levels and to deprive the Purchaser of the benefits of free and open competition.

3.47.2.2 **If the Contractor:**

- a. has abandoned or repudiated the Contract
- b. has without valid reason failed to commence Works promptly
- c. persistently fails to execute the Contract in accordance with the Contract or persistently neglects to carry out its obligations under the Contract without just cause
- d. refuses or is unable to provide sufficient materials, services or labour to execute and complete the Works in the manner specified in the Program furnished under GCC.20 (at rates of progress that give reasonable assurance to the Purchaser that the Contractor can attain Completion of the Works by the Time for Completion as extended).

Then the Purchaser may, without prejudice to any other rights it may possess under the Contract, give a notice to the Contractor stating the nature of the default and requiring the Contractor to remedy the same. If the Contractor fails to remedy or to take steps to remedy the same within fifteen (15) days of its receipt of such notice, then the Purchaser may terminate the Contract forthwith by giving a notice of termination to the Contractor that refers to this clause GCC 3.47.2.

3.47.2.3 Upon receipt of the notice of termination under **GCC 3.47.1** or **GCC 3.47.2** the Contractor shall, either immediately or upon such date as is specified in the notice of termination

- a. cease all further work, except for such work as the Purchaser may specify in the notice of termination for the sole purpose of protecting that part of the Works already executed, or any work required to leave the Site in a clean and safe condition
- b. terminate all subcontracts, except those to be assigned to the Purchaser pursuant to paragraph (d) of GCC 3.47.2.3
- c. deliver to the Purchaser the parts of the Works executed by the Contractor up to the date of termination
- d. to the extent legally possible, assign to the Purchaser all right, title and benefit of the Contractor to the Works and to the Equipment/Materials as at the date of termination, and, as may be required by the Purchaser, in any subcontracts concluded between the Contractor and its Sub-contractors
- e. deliver to the Purchaser all drawings, Specifications and other documents prepared by the Contractor or its Sub-contractors as at the date of termination in connection with the Works

3.47.2.4 The Purchaser may enter upon the Site, expel the Contractor, and complete the Works itself or by employing any third party. The Purchaser may, to the exclusion of any right of the Contractor over the same, take over and use with the payment of a fair rental rate to the Contractor, with all the maintenance costs to the account of the Purchaser and with an indemnification by the Purchaser for all liability including damage or injury to persons arising out of the Purchaser's use of such Equipment/ Materials, any Contractor's Equipment owned by the Contractor and on the Site in connection with the Works for such reasonable period as the Purchaser considers expedient for the supply and installation of the Works.

3.47.2.5 Upon completion of the Works or at such earlier date as the Purchaser thinks appropriate, the Purchaser shall give notice to the Contractor that such Contractor's Equipment will be returned to the Contractor at or near the Site and shall return such Contractor's Equipment to the Contractor in accordance with such notice. The Contractor shall thereafter without delay and at its cost remove or arrange removal of the same from the Site.

3.47.2.6 The Purchaser shall not be liable to make any further payments to the Contractor until the costs of execution and all other expenses incurred by the Purchaser in completing the Work or its turnkey work Package, as the case may be, have been ascertained.

If the Cost of Completion when added to the total amounts already paid to the Contractor as at the date of termination exceeds the total amount which would have been payable to the Contractor for the execution of the Work or work Package, as the case may be, the Contractor shall upon demand, pay to the purchase the amount of such excess. Any such excess shall be deemed a debt due by the Contractor to the Purchaser shall be recoverable accordingly. If there is no such excess the Contractor shall be entitled to be paid the difference (if any) between the value of the Work or its work package and the total of all payment received by the Contractor as a the date of termination.

3.47.2.7 If the Purchaser completes the Works, the cost of completing the Works by the Purchaser shall be determined.

If the sum that the Contractor is entitled to be paid, pursuant to **GCC 3.47.2.6** , plus the reasonable costs incurred by the Purchaser in completing the Works, exceeds the Contract Price, the Contractor shall be liable for such excess.

The Purchaser and the Contractor shall agree, in writing, on the computation described above and the manner in which any sums shall be paid.

3.47.2.8 No account shall be taken of any increased cost which results from the Contractor's default or negligence.

3.47.3 In this clause **GCC 3.47**, the expression "Works executed" shall include all work executed, Installation Services provided, any and Equipment/ Material acquired (or subject to a legally binding obligation to purchase) by the Contractor and used or intended to be

used for the purpose of the Works, up to and including the date of termination.

3.48. ASSIGNMENT & SUB-CONTRACTING

3.48.1 The whole of the works included in the Contract shall be executed by the contractor and the contractor shall not directly or indirectly transfer, assign or underlet the contract or any part, share or interest therein without the written consent of the Purchaser.

3.48.2 No sub-contracting shall relieve the Contractor from the full and entire responsibility of the Contract or from the active superintendence of the work during their progress.

3.48.3 The contractor has to engage specialized agencies / personnel depending upon the nature and complexity of the work with the prior approval of the Purchaser.

To this regard, the contractor has to submit the completion certificates / required documents of similar type of works executed by the subcontractor/ specialized agencies to establish the subcontractor's/specialized agencies' workmanship. Also the contractor has to submit drawings done by the specialized agency for approval of Purchaser before procuring and installing the item. This does not in any way relieve the contractor of his obligations to get the quality work and architectural design as desired by the Purchaser.

3.49. JOINT AND SEVERAL LIABILITY

3.49.1 If the Contractor has formed a Consortium of not more than 2 (two) persons for implementing this Solar Power Project:

(a) These persons shall, without prejudice to the provisions of this Agreement, be deemed to be jointly and severally liable to the WBPDC for the performance of the Agreement; and

(b) The Contractor shall ensure that no change in the composition of the Consortium is effected without the prior consent of the WBPDC

3.49.2 In case of Consortium, without prejudice to the joint and several liability of all the members of the Consortium, the Lead Member shall represent all the members of the Consortium and shall at all times be liable and responsible for discharging the functions and obligations of the Contractor. The Contractor shall ensure that each member of the Consortium shall be bound by any decision, communication, notice,

action or inaction of the Lead Member on any matter related to this Agreement and the WBPDCCL shall be entitled to rely upon any such action, decision or communication of the Lead Member only. The WBPDCCL shall have the right to release payments solely to the Lead Member and shall not in any manner be responsible or liable for the inter se allocation of payments among members of the Consortium.

If member of the consortium fails to perform satisfactorily then the Lead Member will be liable and responsible for completion of the project.

3.49.3 Issue of LOA and Contract agreement will be conferred with the Lead Member only.

SECTION -IV

SPECIAL CONDITION OF CONTRACT (SCC)

The following Special Conditions of Contract are supplementary, to the General Conditions of Contract. Whenever there is a conflict, the provisions herein shall prevail over those in the General Conditions of Contract.

4.1 DEFINITION

4.1.1. Purchaser means The West Bengal Power Development Corporation Limited (WBPDCCL).

4.1.2. Site means the project site. The details of the site is shown below:

Capacity of the Plant	10MW
Selected Location	Sagardighi Thermal Power Station, in Murshidabad District, West Bengal.
Latitude:	24° 36' North
Longitude:	88° 11' East
Altitude:	37 meters
Nearest Major Towns	Ajimganj, Jangipur, Raghunathganj
Nearest police station:	Sagardighi PS (10 km from site)
Nearest hospital:	Raghunathganj (14 km from site)
Nearest substation of SEB	Raghunathganj (5 km from site)
Solar insolation:	5.37 kWh/m ² /day
Seismic Zone	Zone-III as per IS 1893-1984.
Access by Road	From National Highway (NH-34).
Access by Rail	Manigram R.S. on Bandel-Barhawara branch line.
Access by Sea	Nearest port is Kolkata.
Access by Air	Netaji Subhas Chandra Bose International Airport at Dum Dum in Kolkata.

4.1.3. Engineer In Charge

The Director (Projects), WBPDCCL Corporate office, Kolkata or his authorised Engineer will be Engineer In Charge.

4.1.4. Controlling Officer

The General Manager of SgTPP or his authorized Engineer will be Controlling Officer

4.1.5. Project Manager

Project Manger will be selected from the Corporate office and will be finalized in the kick off meeting at the Corporate office of WBPDCCL.

4.1.6. Paying Officer

The Deputy General Manager (F&A), WBPDCCL Corporate office, Kolkata

4.2 CONTRACT PERFORMANCE GUARANTEE

4.2.1. Within fifteen days (15) from date of LOA, the Contractor shall furnish Performance Guarantee to the Purchaser amounting to 10% of the accepted Tender Value in the form of Bank guarantee from nationalized bank. The (Earnest Money Deposit) EMD shall be returned on submission of the Performance Guarantee of success full bidders.

4.2.2. **Release of Contract Performance Bank Guarantee (PBG):** 100% after the completion of defect liability period i.e. 5 years after successful commissioning of the Project.

4.2.3. Contract agreement will be executed after submission of PBG, deposited EMD shall be returned.

4.3 PAYMENTS

Following terms of payment shall be applicable –

4.3.1. Security Deposit (SD)

a) 5% of the bill value shall be deducted from every bill. SD will be released after the payment of final bill.

b) No Interest is payable on the Security Deposit.

4.3.2. Performance Security:

10% of contract value will be retained and it will be released in five equal installments every year in the defect liability period subject to compliance of following conditions by the contractor:

Integrated project performance of Net Minimum Guaranteed Generation (NMGG) solar energy at rate of **1.52MU/MWp** annually **with degradation of 1%** for any reason, from second year onwards. If generated units fall short, then **Rs.6.50** per unit of short fall will be deducted from WBPDCCL payments every year up to 5th year.

4.3.3. Total Integrated System Warranty/Contract Performance Guarantee

- a. After completion of the project the 10% contract performance bank guarantee (PBG) will be the total integrated System warranty.
- b. PBG will be returned to the contractor after successful completion of the defect liability period as well as O&M period.

4.3.4. PAYMENT TERMS

4.3.4.1 Within forty-five (45) days after receiving an application for payment, duly complete in all respects, the Purchaser shall pay the amount certified after issue of each certificate of payment to the Contractor at his principal place of business.

4.3.4.2 Mobilization Advance:

- i. 10 % of the Contract Price (Supply & Erection contract) will be paid as Mobilization advance to the contractor against submission of Mobilisation Advance Bank Guarantee (**ABG-Annexure-3**) equivalent to 110 % of the Mobilisation Advance, subject to the conditions mentioned below. Unconditional acceptance of the LOA.
- ii. Taking over of site from WBPDC
- iii. Execution of Contract Agreement
- iv. Submission of Performance Bank Guarantee
- v. Submission of duly authenticated Activity Schedule in MS Project showing the entire execution of work.
- vi. The Bank Guarantee shall be valid for a total period of 12 (twelve) months plus a claim period of 3 (three) months from the bid opening date.
- vii. Mobilization advance, so paid shall be recovered as mentioned in the **Payment Schedule (clause SCC 4.3.4.6)**.
- viii. Bank Guarantee submitted for mobilization advance will be released after full recovery of the mobilization advance and on receipt of written request of the contractor for release of the same.

The mobilization advance will be recovered with interest at the Base Rate of State Bank of India, the base rate as applicable on the date of advance payment shall be considered for computation of interest. The closing date for calculation of levy of Interest shall be the date of issuance of Material Received Certificate (MRC) and Erection Completion Certificate.

The levy of Interest may be waived off subject to the condition that the contractor submits claims against supplies and services as payable as per **clause no.4.3.4.6** within a period of 90(ninety) days from the date of LOA. The payable claim amount must be more than the initial advance paid.

4.3.4.3 Supply of Materials:

Payment for supply of material at site will be given as per the **Payment Schedule (clause SCC 4.3.4.6)** given below after satisfactory acceptance by Purchaser of the supplied materials along with the relevant following documents mentioned:

I. Deduction:-

- a) Statutory deductions like TDS, GST if any shall be deducted.
- b) Adjustment of any excess / short payment made in the earlier bills, at the time of making payments.
- c) Electricity and Water charges will be recovered as per tender terms.
- d) Value of chargeable materials if any issued by the Purchaser.
- e) Any other recovery if due as per tender terms & conditions.
- f) 5% of the bill value as Security Deposit.

II. Documents:-

- a) Computerized detailed measurements, Running Accounts Bills and Final Bill will be Prepared by contractor and submitted to WBPDCCL for verification and approval.
- b) Document for claiming subsidy from MNRE should be submitted to WBPDCCL for release of first RA bill.
- c) WBPDCCL gate entry documents./MRC(Material Receive at Certificate)
- d) Relevant test, type test, joint inspection reports warranty and guarantee Certificate for the items supply as per quality criteria mentioned in tender document.

- e) Copy of Performance guarantee for contract execution from nationalized bank valid till completion of work for 10% of purchase order value.
- f) Labor License (as per statutory requirements).
- g) EPF Code Registration number with RPF.
- h) Insurance – Contractor’s All Risk (CAR) Policy.
- i) Workmen compensation policy, Proof for PF deduction and remittance.
- j) Third Party Liability Insurance for four consecutive occurrences each occurrence of 5.0 lakh.
- k) GST or Other tax invoice, Service Tax registration number.
- l) Indemnity Bond (ANNEXURE-5) in standard pro forma to indemnify the Purchaser against all risks arising during the performance of the contract.
- m) Proof of deployment of project engineers as specified in SCC.
- n) Challans / receipts of taxes paid to statutory authorities i.e., GST, Custom duties etc.
- o) A Certificate towards the effect that minimum Technical and Safety man power was employed for the work execution Certified by the WBPDC representative as per the Tender Clauses.
- p) Undertaking for compliance of all labor laws.

4.3.4.4 Payment of Bills for installation, erection, testing, integration, successful commissioning of integrated system in total and ready for handing over to WBPDC

Payment for the Bill amount for the materials quoted will be paid as per the **Payment Schedule (clause SCC 4.3.4.6)** after joint inspection / measurements by the Purchaser for installation, erection, testing, integration, successful commissioning of integrated system in total and ready for handing over to WBPDC by the contractor and submission of following document :

I. Deduction:-

- a) Deduction of the Value of chargeable materials if any issued by the Purchaser.
- b) Statutory deductions like TDS, GST, Custom duties if any.
- c) Charges for Electricity and Water charges provided by WBPDC.

- d) Any other recovery if due as per tender terms & conditions.
- e) 5% of the bill value as Security Deposit.
- f) Adjustment towards any excess / short payment made in the earlier bills.

II. Document:-

- a) Relevant test, type test, joint inspection reports warranty and guarantee Certificate for the items installed, integrated & commissioned as per quality criteria mentioned tender document.
- b) WBPDCCL gate entry documents if any.
- c) Proof of deployment of project engineers as specified in SCC.
- d) Challans / receipts of taxes paid to statutory authorities i.e., GST, Customs Duties etc
- e) A Certificate towards the effect that minimum Technical and Safety man power was employed for the work execution Certified by the WBPDCCL representative as per the Tender Clauses.
- f) Undertaking for compliance of all labor laws.
- g) Valid Indemnity Bond in standard pro forma indemnifying the Purchaser against all risks arising during the performance of the contract.
- h) Valid Workmen compensation policy, Proof for PF deduction and remittance.
- i) Valid Insurance – Contractor’s All Risk (CAR) Policy.
- j) Valid Labor License (as per statutory requirements).
- k) MNRE–Govt of India format project complication certificates / documents to WBPDCCL.
- l) Computerized detailed measurements, Running Accounts Bills and Final Bill will be prepared by contractor and submitted to WBPDCCL for verification and approval.
- m) A Certificate issued by the WBPDCCL that total supply and erection works are complete in all aspects.

4.3.4.5 Payment of Bill – Performance testing of total integrated system – final Payment / bill:

Payment for materials bill shall be paid as per the **Payment Schedule as per clause SCC 4.3.4.6** after performance testing of total integrated system for two months in all respect. The final bill complete in all respect shall be submitted by the contractor within 60 days from the completion of the work. The bill should be accompanied with the following documents.

I. Deduction:-

- a) Statutory deductions like GST and other tax and duties if any shall be deducted WBPDCCL reserves the right to adjust any excess / short payment made in the earlier bills, at the time of making payments.
- b) Adjustment of any excess / short payment made in the earlier bills, at the time of making payments.
- c) Electricity and Water charges will be recovered as per tender terms.
- d) Value of chargeable materials if any issued by the Purchaser.
- e) LD if any and other recovery if due as per tender terms & conditions.

II. Document:-

- a) Computerized detailed measurements, Running Accounts Bills and Final Bill will be Prepared by contractor and submitted to WBPDCCL for verification and approval.
- b) Validated of Total Integrated System Warranty PBG/Contract PBG valid for 66 months for the value equivalent to 10% of the total final project value from nationalized bank.
- c) Proof of project completion and relevant documents as per MNRE format for release of subsidy by MNRE, Govt of India to WBPDCCL.
- d) Job completion certificate by WBPDCCL (**Annexure-6**).
- e) No claim certificate on Purchaser's prescribed pro forma - if any deduction is to be made for short fall, Purchaser shall record the same in this document.
- f) Site clearance certificate by WBPDCCL.
- g) Indemnity certificate towards labor payment and all statutory payments.
- h) Copy of the insurance policy. (Workmen compensation act and contractors all risk policy).

- i) Operation and Maintenance manuals and testing and commissioning reports with Guarantee and Warranty certificates.
- j) Statutory Compliance certificate towards payment of insurance, GST and other taxes if any applicable.
- k) A compliance Certificate should be submitted towards deployment of Technical & Safety man power as per the relevant Tender Clauses.
- l) Proof of deployment of annual maintenance & operation manpower for operation of the plant.
- m) Valid Workmen compensation policy, Proof for PF deduction and remittance for AMC personal.
- n) Valid Insurance – Contractor’s All Risk (CAR) Policy for AMC personnel.
- o) Valid Labor License (as per statutory requirements) for AMC personnel.
- p) Relevant test, type test, joint inspection reports warranty and guarantee Certificate for the items installed, integrated & commissioned as per quality criteria mentioned tender document.
- q) WBPDCCL gate entry documents if any.
- r) Undertaking for compliance of all labour laws.
- s) Valid Indemnity Bond (ANNEXURE-5) in standard pro forma indemnifies the Purchaser against all risks arising during the performance of the contract.
- t) Final acceptance certificate issued by WBPDCCL /Purchaser.

4.3.4.6 Payment Schedule:

Sl. No.	Work Head	Pattern of Release of Billing Amount
1	Mobilization Advance	10% of the total contract price of Supply and Erection & Commission will be paid as Mobilization advance to the contractor against submission of Mobilisation Advance Bank Guarantee (ABG) equivalent to 110 % of the Mobilization Advance, subject to the conditions mentioned in the Clause No. SCC 4.3.4.2 above. The mobilization advance will be recovered as per the sub clause mentioned

Sl. No.	Work Head	Pattern of Release of Billing Amount
		in Sl. No. 2 (i) & 3(i) below.
2	Contract for Supply of Material	i. 65% of the contract value will be given after material received at site (Mobilization Advance paid and interest as per Clause 4.3.4.2 will be recovered proportionately from bills under this phase of payment).
		ii. 15% of the contract value will be paid after completion of the erection of the material
		iii. 10% of the contract value after successful completion of the commissioning and all testing and release of 5% security deposit as per clause No.4.3.1 which is the final bill
		iv. 10% of the Contract value will be retained for Performance warranty as per clause no.SCC 4.3.2..
		v. 5% of the Security Deposit (SD) will be deducted from the bill of sl. No. i to iii.
3	Contract for Erection & Commissioning	i. 65% of the contract value will be given after erection of the material (Mobilization Advance paid and interest as per Clause 4.3.4.2 will be recovered proportionately from bills under this phase of payment).
		ii. 15% of the contract value will be paid after completion of the Commission of the material
		iii. 10% of the contract value after successful completion of the commissioning and all testing and release of 5% security deposit as per clause No.4.3.1 which is the final bill.
		iv. 10% of the Contract value will be retained for Performance warranty as per clause no.SCC 4.3.2.
		v. 5% of the Security Deposit (SD) will be deducted from the bill of sl. No. i to iii.

4.3.5. Performance Penalty:

- a) Integrated project performance of minimum solar energy to be generated 1.52MU/MWp annually with degradation of 1% for any reason, from second year onwards. If generated units fall short, then Rs.6.50 per unit of short fall will be deducted from WBPDC payments every year up to 5th year.
- b) Penalty will be deducted from retained Performance Security but if Performance Security ended then penalty will be recovered by invoking PBG
- c) WBPDC reserves the right to adjust any excess / short payment made in the earlier bills, at the time of making payments.

4.3.6. Defects Liability Period:

Defect liability period is 60 calendar months from the date of Issue of Final completion certificate/Acceptance of work by WBPDC.

4.3.7. INCREASE IN COST:

Quoted prices are firm and no escalation charges on any account are allowed in this work. No claim will be entertained on this account in future.

4.3.8. DISALLOWANCE OF PAYMENT:

If payment has been made for any item but later on some defect is noticed, Purchaser is authorized to disallow payment of the subsequent bill till rectification /replacement of the item.

4.4 ESCALATION

No Escalation shall be paid on any account.

4.5 LIQUIDATED DAMAGES

0.5% of contract value per week of delay up to a maximum of 10% (Ten percent) of the Contract value from the stipulated date of completion.

4.6 NOTICES

For the purpose of all notices, the following shall be the address of the Purchaser and the Contractor.

PURCHASER:

The Director (Projects)
The West Bengal Power Development Corp. Ltd.
Bidyut Unnauan Bhaban, Plot No. 3/C LA-Block,
Sector-III, Bidhannagar,Kolkata-700 106

CONTRACTOR:

(To be filled in at the time of Signing of the Contract)

4.7 LABOUR

4.7.1.The Contractor shall make his own arrangements for the engagement of all staff and labor, local or other, and for their payment, housing, food, transport etc. No labor to stay at site.

4.7.2.The Contractor shall, if required by the Purchaser deliver to the Purchaser a return in detail, in such form and at such intervals as the Purchaser may prescribe, showing the staff and the numbers of the several classes of labor from time to time employed by the Contractor on the Site and such other information as the Purchaser may require.

4.7.3.Compliance with labor regulation: During continuance of the contract, the Contractor shall abide at all times by all existing labor enactments and rules made there under, regulations, notifications and bye-laws of the State or Central Government or local authority and any other labor law (including rules), regulation by laws that may be passed or notifications that may be issued under any labor law in future either by the State or the Central Government or the local Authority. The Contractor shall keep the Purchaser indemnified in case any action is taken against the Purchaser by the competent authority on account of contravention of any of the provisions of any Acts or rules made there under, regulation or notifications including amendments. If the Purchaser is caused to pay or reimburse, such amount as may be necessary to cause or observe, or for non-observance of the provisions stipulated in the notifications/bye laws/Acts/Rules /regulations including amendments, if any, on the part of the Contractor, the Purchaser shall have the right to deduct from any money due to the Contractor including his amount of performance security. The Purchaser shall also have right to recover from the Contractor any sum required or estimated to be required for making good the loss or damage suffered by the Purchaser

4.7.4.The employees of the Contractor and the Sub-Contractor in no case shall be treated as the employees of the Purchaser at any point of time.

4.7.5.No labor shall stay at site. Temporary storage space provision should be made by contractor.

4.7.6.The rates shall be complete in all respects i.e. inclusive of all taxes, local taxes, work contract tax, Insurance charges nothing on any account shall be paid over the approved rate.

4.7.7.All specialized and specific jobs shall be carried out by approved agencies/vendors only.

4.7.8.The Contractor shall arrange temporary drinking water and sanitation facilities for his workmen.

4.7.9. Minimum Wage as applicable

- i. The contractor shall pay not less than fair wages to laborers engaged by him on the work.
- ii. "Fair" wages means wages whether for time or piecework notified by the Government from time to time for the locality of work.
- iii. The contractor shall not-with-standing the revisions of any contract to the contrary cause to be paid to the labor directly engaged on the work including any labor engaged by the sub-contractor in connection with the said work, as if the laborers had been directly employed by him.
- iv. In respect of labor directly or indirectly employed in the works for the purpose of the contractors part of the agreement the contractor shall comply with the rules and regulations on the maintenance of suitable records prescribed for this purpose from time to time by the Government. He shall maintain his accounts and vouchers on the payment of wages to the laborers to the satisfaction of the Purchaser.
- v. The Purchaser shall have the right to call for such record as required to satisfy himself on the payment of fair wages to the laborers and shall have the right to deduct from the contract amount a suitable amount for making good the loss suffered if any by the worker or workers by reason of the "fair wages" clause to the workers.
- vi. The contractor shall be primarily liable for all payments to be made and for the observance of the regulations framed by the Govt., from time to time without prejudice to his right to claim indemnity from his sub-contractors.
- vii. As per contract labor (Regulation and abolition) Act.1970 the contractor has to produce the license obtained from the licensing officers of the

labor department along with the tender viii. Any violation of the conditions above shall be deemed to be a breach of his contract.

- viii. Equal wages are to be paid for both men and women if the nature of work is same and similar.
- ix. The contractor shall arrange for the recruitment of skilled and unskilled labor local and imported to the extent necessary to complete the work within the agreed period as directed by the Purchaser.
- x. The Contractor/Sub-contractor(s) to be engaged by the contractor subsequently, must have its own PF & ESI Code.

4.8 SAFETY MEASURES

The contractor shall take necessary precautions for safety of the workers and preserving their health while working in such jobs, which require special protection and precautions. The Purchaser has standard safety guidelines for the Contractor. The Contractor is to be followed the above guidelines which will be provided with placement of the Award of Contract.

4.9 FIRE FIGHTING MEASURES

- i. The contractor shall provide and maintain adequate firefighting equipment and take adequate fire precaution measures for the safety of all personnel and temporary and permanent works and shall take action to prevent damage and destruction by fire of trees shrubs and grasses.
- ii. Separate payment will not be made for the provision of fire prevention measures.

4.10 DEPLOYMENT OF MANPOWER

The contractor shall deploy the following minimum man power at site to take instructions from WBPDCCL Staff & Report the site activities on day to day basis execution of quality work and maintain all statutory records as per Govt. norms/as directed by the Purchaser.

- 4.10.1.** One Graduate Engineer (Electrical) with suitable experience of 8 years and one junior Engineer Diploma (Electrical) of 5 years experience, two nos of ITI and at least some unskilled manpower for day to day operation the contractor shall furnish the name, bio data, experience of the personal intended to be posted at site at the start of work. Site Engineers are to be deployed irrespective of the Contractor or the Director / Manager of the contracting

company being an Engineer himself. Attendance register should be kept at the office of WBPDCCL designated engineer.

4.10.2. The Contractor shall maintain supervisor staff to Labor ratio as per standard government / CPWD norms.

4.10.3. The Contractor may employ more number of site Engineers other than above mentioned Engineers to get quality workmanship and maintain all statutory.

4.11 QUANTITY OF WORK

The quantities of work shall be mentioned in the LOA.

4.12 PROJECT MANAGEMENT

4.12.1. CONTRACTOR'S ORGANISATION

The Contractor shall supply to the Purchaser and the Project Manager a chart showing the proposed organization to be established by the Contractor for carrying out work on the Facilities within twenty-one (21) days of the Effective Date. The chart shall include the identities of the key personnel and the curricula vitae of such key personnel to be employed shall be supplied together with the chart. The Contractor shall promptly inform the Purchaser and the Project Manager in writing of any revision or alteration of such an organization chart.

4.12.2. PROGRESS REPORT

Monthly progress report of the previous month along with photographs of work progress shall be submitted to the Purchaser before the 7th day of every month. Format for the monthly report will be finalized in the .Kick Off meeting.

4.12.3. PROJECT REVIEW MEETING

Progress of the project will be evaluated in the Project Review Meeting (PRM) in every month. Date of the PRM will be informed by the Purchaser to the entire contractor.

4.12.4. SPECIAL PROJECT REVIEW MEETING

Special Project Review Meeting (SPRM) will be held after completion of the each milestone mentioned in the data sheet (approved network by the Purchaser). In this meeting the total time taken for complete the milestone will be finalized/evaluated and if any delay occurs then delay contribution will be calculated and minuted by both Contractor as well as Purchaser.

4.13 ACCIDENT OR INJURY TO WORKMEN

- 4.13.1. WBPDC shall not be responsible for any injury or loss of life of any worker of the contractor that may take place while on work. Any compensation or expenditure towards treatment for such loss of life or injury shall be the sole responsibility of the contractor.
- 4.13.2. The contractor is solely responsible for any damage injury or accident that may occur to any of his personnel working under this contract. He will not claim any compensation from WBPDC.

4.14 REGULATIONS & STANDARDS

The installation shall conform in all respects to the Indian Standard Code of Practice for Electrical Installations. It shall also be in conformity with the current Indian Electricity Rules and Regulations and requirements of the local Electric Supply Authority in so far as these become applicable to the installation. Wherever the specifications of this tender document calls for higher standard of material and/or workmanship than those required by any of the above codes and regulations then this specifications shall take precedence over the said regulations and standards.

4.15 INSPECTION AND TESTING

- 4.15.1. Required Inspection charges at the Factory are under scope of Contractor.
- 4.15.2. Inspection & Testing for Imported items like Inverters, Floaters etc may be done at Manufacturer local testing facilities / at the works of the contractor in India as desired by the contractor. In such case the contractor shall provide full set up for inspection and routine test of the item.

4.16 DESIGN AND ENGINEERING

- 4.16.1. The optimum system design and sizing of the equipments of the PV power plants shall be done by using design software PV- Syst /PV-Sol or any other modern tools by using the meteorological data base of Meteoronorm.
- 4.16.2. The contractor shall develop the general layout drawing of Array Yard, Inverter, AJB, Grid Interfacing panel, Single line diagram and other drawing as may be required. All designs & drawings are to be developed based on specification given in the tender, relevant BIS unless otherwise specified.
- 4.16.3. The Power Plants shall have to be designed considering optimal usage of space without compromising the effect of shadow, cooling, accessibility, losses, protection, security and safety etc.
- 4.16.4. Document to be submitted during approval of the Design and Drawing:

During approval of drawing and design of the PV Power Plant the documents have to be submitted by the contractor which shall be includes but not limited as follows:

- 1) Power plant design document
- 2) PV Array and other component layout drawing of the PV Power Plant
- 3) Drawing of different equipments of PV power Plant
- 4) Design and drawing of PV Module mounting floater along with the anchoring arrangement of PV array as per technical specification.
- 5) List of Equipments and Component and its capacity and manufacturer name to be used in the PV Power Plants
- 6) Type test report of PV Module mounting floater, Inverters, PV Module, Cables , Components of Array JB, Inverter LT Panel, Grid Inter facing Panels etc
- 7) Technical catalog of the Equipments and Component.

4.17 COMPLETION OF WORK

The Contractor shall assist the beneficiaries and liaison with the DISCOMs if necessary for installation of Net Meter by the DISCOM and complete the formalities for availing net metering benefit to make the power plant is operational from the date of commissioning.

4.18 TRAINING OF OWNER'S ENGINEER

Contractor will arrange for training on Operation and maintenance of owners engineer in a floating solar power plant, capacity not less than 1MW and which is in successful operation since last three years or capacity not less than 5MW which is in successful operation since last two years from the date of LOA. Expenses for Transportation, Boarding, Lodging for Thirty Two man days (four man for eight days) to be born/arranged by the contractor. Contractor will also facilitate for arrangement of visas for the country to be visited.

The Contractor will also arrange for training at site for the end users.

4.19 TAKING OVER

The work shall be taken over by WBPDC upon successful completion of work at site(s) and observing performance of the power plant **for at least 30 days** in accordance with provision of this work. During handing over of the complete project work, the contractor will submit the followings in Six (06) sets for considering final payment.

- a) All As-Built Drawings & Design of the power plant

- b) Detailed Engineering Document with detailed specification, schematic drawing, Design and test results, manuals for all deliverable major items, Operation, Maintenance & Safety Instruction Manual and other information about the project
- c) Bill of materials
- d) Site wise documentation as per MNRE GoI Format
- e) Performance Guarantee Certificate of PV modules from the original manufacturer
- f) Inventory of spares at projects sites
- g) Completion certificate as per prescribed format provided by WBPDCCL
- h) 30 days Generation Data.
- i) Project Document as per MNRE Guideline
- j) Site maintenance logbook.

4.20 COMPREHENSIVE MAINTENANCE

Comprehensive Maintenance during defect liability period

4.20.1. All the equipments to be installed for commissioning of each of the grid connected solar PV power plant and the power plant in whole shall be under Comprehensive Maintenance Contract within the scope of the tender for 5(five) years from the date of commissioning. The equipments or components, or any part thereof, so found defective during Comprehensive Maintenance Contract period will be forthwith repaired or replaced within the scope of guarantee obligation to the satisfaction of the Purchaser.

The maintenance of grid connected solar PV power plant include routine & periodic maintenance, overhauling, breakdown maintenance, and repairing or replacement of defective PV modules, invertors, and other components, providing of consumables. The Down-Time of PV system should not be more than 72 hours (03 days). Details of the maintenance scope are mentioned in the clause no. **GCC 3.8.4**

4.20.2. **Routine maintenance:**

In order to carry out routine maintenance of the power plant, the contractor will provide all labour, material, consumables etc. within the scope of maintenance service. Recommended tusks under the scope of routine maintenance will include but not limited to the followings:

Sl No.	Type of Routine Maintenance
01	Checking and tightening of all electrical connections

Sl No.	Type of Routine Maintenance
02	Checking and tightening of mechanical fittings
03	Checking and restoring of earthing system
04	Dusting and cleaning of Inverter and other electrical equipments
05	Routine maintenance as recommended by the Original Equipment Manufacturer (OEM)

4.20.3. Rental and Other Periodic Charges

The contractor shall pay the rental charge of the SIM / Telephone Bill web connectivity in order to transfer of data related to Web Based Remote Monitoring System. The contractor shall also pay the rental charges for server of the web based remote monitoring system for storing and access the data till the defect liability period is over. The Contractor shall also pay necessary charges periodically for refilling of the Fire Extinguisher till defect liability period is over.

4.20.4. The payment towards Operation & Maintenance shall be made on monthly basis on submission of bills in triplicate to WBPDCCL along with a copy of the maintenance report during the claimed period.

4.21 WARRANTY OF EQUIPMENT

The contractor shall warrant that all equipments, hardware and accessories are new, unused, most recent or current models and incorporate all recent improvements in design and in accordance with the contract documents and free from defects in material and workmanship. The contractor shall also guarantee for defect free operation of the materials supplied and workmanship towards erection for a period of **sixty (60) calendar months** commencing immediately upon date of TOC.

4.22 MANUFACTURER WARRANTY CERTIFICATE:

The manufacturer should warrant the supplied equipments, hardware and accessories free from the defects and/or failures specified below from the date of sale to the original customer (i.e. EPC Contractor).

- i. Defects and/or failures due to manufacturing
- ii. Defects and/or failures due to quality of materials
- iii. Non conformity to specifications due to faulty manufacturing and/or inspection processes.

If any equipment fails to conform to this warranty, the manufacturer will replace the equipments, at the Purchaser's sole option.

The contractor has to submit the Warrantee Certificate issued by the Equipments Manufacturer to WBPDCCL against delivery of each lot. The Warrantee Certificate issued by the contractor must comprise order no. of WBPDCCL, name of the project and name of WBPDCCL.

The contractor should submit the warrantee certificate issued by the original Equipments manufacturer to WBPDCCL after delivery of every lot. The warrantee shall include but not limited to the following:

- a) Capacity and model of the Equipment,
- b) Equipment serial no.
- c) Warrantee period:
- d) Name of WBPDCCL (as principal purchaser)
- e) Order reference of WBPDCCL
- f) Order reference & name of the of vendor

4.23 PERFORMANCE GUARANTEE OF PV MODULE:

The manufacturer should warrant the output of Solar Module(s) for at least 90% of its rated power after initial 10 years & 80% of its rated power after 25 years from the completion of trial run at site/date of final commissioning. The contractor shall collect the Warranty Certificate for performance of the modules from the manufacturer and submit the same to WBPDCCL prior to delivery of the products to the respective sites.

If, Module(s) fail(s) to exhibit such power output in prescribed time span, the Contractor will bound to either deliver additional PV Module(s) to compensate the shortfall power output with no change in area of site used or replace the PV Module(s) with no extra cost claimed at Purchaser 's sole option.

The contractor has to transfer Performance Guarantee Certificate of the module from the original manufacturer to the Purchaser for subsequent arrangement after completion of the guarantee period.

4.24 KICK OFF MEETING

Project Kick Off meeting to be held within 15 days of the placement of LOA and venue of the kick off meeting will be the Corporate Office of WBPDCCL.

4.25 CLEAN-UP AND WASTE DISPOSAL

Contractor shall keep the power project site reasonably clean and otherwise free from accumulation of waste materials, rubbish and other debris resulting from performance of the EPC Contractor's obligations. Contractor shall be

maintained project site at hygienic standards and shall be kept reasonably free from debris, litter and malodour on or before Final Performance Acceptance. The EPC Contractor shall remove from the power plant site area all petroleum, waste materials, rubbish and other debris, as well as all tools, construction equipment, machinery and surplus material which the Client does not hold title, and shall make the power plant area in a neat, clean and usable condition. The EPC Contractor shall remove, transport and dispose-off hazardous material transported into the power plant site or any subcontractor or created, used or handled as part of contractor's or any subcontractor's construction activities at the power plant site.

The EPC Contractor shall notify Purchaser immediately upon the discovery of presence of any hazardous material on, or the release of hazardous material on or from, the power plant site. All clean up and disposal activities of contractor (including, without limitation, the transportation and disposal of any hazardous materials taken from the power plant site) shall be conducted in accordance with all Applicable Laws and Applicable Permits. All these shall be applicable during the O&M period also in mutatis mutandis.

SECTION –V

TECHNICAL SPECIFICATION

A. GENERAL REQUIREMENTS:

5.1 NAME OF THE WORK:

Setting up 10 MW Grid connected Floating Solar Photovoltaic Power Plants on Raw Water Pond no.1, 2&4 in Sagardighi Thermal Power Project (SgTPP), Murshidabad, West Bengal.

5.2 SCOPE OF THE WORK:

Design & Engineering, Manufacture/Procurement, Supply, Installation, Testing and Commissioning of 10 MW Grid connected Floating Solar Photovoltaic Power Plants on Raw Water Pond no.1, 2 & 4 in Sagardighi Thermal Power Project (SgTPP), Murshidabad, West Bengal in turnkey basis including 05 (Five) years warrantee obligation with comprehensive Operation and Maintenance.

5.3 PROJECT SCHEDULE:

Zero date: Date of issue of LOA

Total time for competition: **365** days from zero date.

5.4 MODE OF EXECUTION

The entire work shall be executed on Lump sum turnkey basis. Any item(s) not included in the specification / schedule but required for completion of the work shall have to be carried out/supplied without any extra cost. Such works, not listed in the schedule of works but elaborately described to perform or to facilitate particular operation(s) required for completion of the project shall be deemed to have been included in the scope of this work and the bidder shall supply, install the same without any extra cost to WBDCL.

The work shall be executed in conformity with the relevant standard of Bureau of Indian Specification (or equivalent International Standard), Indian Electricity Rules, 1956 (as amended up to date), Indian Electricity Act 2003(as amended up to date), BARC/DAE rules, Explosive Act 1948, Petroleum Act 1934, National Building Code and relevant Rules in vogue at the time of execution including operation & maintenance period.

The bidder shall comply with all applicable laws or ordinances, codes, approved standards, rules, and regulations and shall procure all necessary Panchayat / Municipal and Government permits & licenses etc at his own cost.

All sub systems /components such as cables, connectors, Junction boxes, surge protection devices, etc., shall conform to the relevant international and national standards for electrical safety besides that for Quality required for ensuring Expected service life and Weather resistance.

The bidder to provide full time round the clock watches and ward to protect the material from theft and pilferage.

5.5 SITE INSPECTION

The bidder is advised to visit and examine project site and its surroundings and obtain for himself, on his own responsibility, all information that may be necessary for entering into contract. The bidder will assess and satisfy himself as to the adequacy of the local conditions such as approach roads to the site, adequacy of existing culverts/bridges/roads for the expected traffic, water and power supply, nature of ground and sub soil condition, water table level, accommodations required during the contract, climatic conditions, local terrain, availability of labour and construction materials, details of taxes, duties and levies as applicable and any other information required. The cost of visiting the site shall be at the bidder's own expenses.

5.6 FACILITIES AT SITE

The Bidder will be provided with a 415V, 3 Phase, 50 HZ power supply at one point near the project location for construction and fabrication purpose but cabling to be done by the Bidder, Control, metering and distribution inside the solar power plant area shall be made by the bidder at his own cost. Cost of the construction power will be charged basis with the rate of WBS&DCL.

Water supply shall be arranged from the lake by the contractor for construction and maintenance purpose of floating solar PV power plant. The Bidder shall arrange for pumps and distribution piping to various locations within the solar power plant depends on the requirement.

B. SYSTEM DESCRIPTION:

5.7 LAYOUT:

- a) **Capacity of the Plant:** 10000kW (AC).

b) Capacity of the Pond:

Approximate pond water surface area and expected estimated power plant capacity:-

Pond	Capacity(SqM)	Capacity(MW)
Raw Water Pond #1	60800	3.5
Raw Water Pond #2	59600	3.5
Raw Water Pond #4	65736	3

Capacity mentioned above is estimated only actual capacity may vary after details engineering.

c) Topography of the Site:

2. Raw Water Pond #1:

- i) 24°21'50.8"N 88°06'53.7"E
- ii) 24°21'46.6"N 88°06'45.1"E
- iii) 24°21'40.6"N 88°06'48.3"E
- iv) 24°21'44.8"N 88°06'57.1"E

3. Raw Water Pond #2:

- i) 24°21'46.3"N 88°06'44.2"E
- ii) 24°21'42.1"N 88°06'35.7"E
- iii) 24°21'36.3"N 88°06'39.0"E
- iv) 24°21'40.4"N 88°06'47.7"E

4. Raw Water Pond #4:

- i) 24°21'38.7"N 88°06'45.7"E
- ii) 24°21'34.8"N 88°06'37.5"E
- iii) 24°21'32.7"N 88°06'38.4"E
- iv) 24°21'31.0"N 88°06'35.2"E
- v) 24°21'28.0"N 88°06'37.0"E
- vi) 24°21'33.0"N 88°06'49.0"E

d) Total depth of the Raw Water Reservoirs is 7.2 m with a free board of 750mm. As this is a reservoir of power plant so generally fixed water level is maintained for whole year but water level may be reduced if scarcity of water from Ganges arises.

e) FLOTATION UNIT FOR MOUNTING OF SOLAR MODULE

The module mounting structure (flotation structure) shall be installed over an appropriately designed modular and pre-fabricated flotation device with appropriate buoyancy to support the weight of at least one solar panel and

one person per solar panel. The total 10MW (AC) plant to be installed in the centre of the pond in a continuous manner.

f) **MOORING AND ANCHORING SYSTEM**

Depending upon the water level variation and prevailing wind speed mooring and Anchoring system will be selected during designing. Water level variation may be considered up to ground level.

g) **WALKWAY**

At least one walkway to be provided between two rows of module to get access of the floating plant module for day to day maintenance work.

h) **INVERTERS/POWER CONDITIONING UNIT (PCU)**

The DC power shall be converted to AC by PCU to supply AC loads. Sizing of Inverter of the Plant will be decided during designing & engineering.

i) **INVERTER CUM CONTROL ROOM**

Total 10MW AC plant to be installed on three raw water ponds as per the clause no.5.7 (b) above. So for each individual Ponds one Inverter cum Control Room to be constructed to place inverters of the said plant and outdoor type oil filled inverter transformers (400v/33kV) to be placed near to the Inverter room.

j) **GRID CONNECTIVITY:**

Power is to be evacuated through 33 kV indoor switchgear present in the floating solar plant control room which shall ultimately evacuate through the common floating solar power evacuation line.

k) **CONTROL BUILDING:**

Bidder shall install Inverter Cum Control room near each Pond along with Transformer Yard.

There is a Common control building present near the Phase-II Raw Water Pump House. This building has two parts, one part for **Equipment Room** for housing Switchgear, electrical equipments/panels and other part for **Control Room** for Control operation, office cum meeting or conference room and equipment room which is having AC environment for the operation & maintenance of entire floating Solar Plant system.

In the Equipment Room only spare space has been kept for accommodating the incoming power of the individual pond power plant. Successful Bidder

shall supply both 33 kV HT extension panels and 415 V LT extension panel, installation connect with the main bus and other hooking up its equipments with the existing 33 kV and 415 V Switchgear. 33 kV cable shall run from new transformer yard near each Pond (Pond no. 1, 2, and 4) to existing Common control Room near Pond No. 3.

l) **THREE WINDING TRANSFORMER**

Three winding outdoor type oil filled step up transformer (0.4kV/0.4kV/33kV) for each pond shall be connected to the outputs of two inverters as input and the 33kV HV output sides will be connected to the 33kV bus of HT switchgear present in existing Common Floating Solar Control room through Protection system, VCB etc.

m) **STATION AUXILIARY TRANSFORMER(SAT)**

One 33kV/415V dry type Station Transformer (100kVA) is already present in the control room for light and other auxiliary purpose. Auxiliary power for this three power plant to be drawn from the Station Service Board (SSB)/ 415 V LT Switchgear and arrangement/refurbishment (if any) to done by the Vendor only.

However Supply installation charging of another similar type 100kVA Station Auxiliary transformer adjacent to main control room is under bidder's scope.

n) **HT SWITCHGEAR**

Inside the existing control room building, 33kV switchgear already have two outgoing and two incoming feeder apart from Bus-coupler, Bus PT, Line PT etc. Existing feeder are connected with following system:

- i. Outgoing Fdr#1: Power transmission/evacuation capacity through Fdr#1 is 20MW.
- ii. Out going Fdr#2: One no. Station Transformer for lighting and other auxiliary consumption,
- iii. Incoming Fdr#1, 2: Two nos. Step-up Inverter Transformers (0.4kV/0.4kV/33kV) of existing floating solar of Raw Water Pond #3.

Present 10MW Power Solar Power shall also be evacuated through the same outgoing Fdr#1. Spare space provision is available in the existing control room for connecting the Solar Power extension panel with the existing 33kV Switchgear present in the Control Room on both sides. So bidder has to design the system accordingly to add other required HT feeders similar to

make, type and rating of existing BHEL make 33 kV switchgear. Details of feeder etc is mentioned under specification of 33 kV HT Switchgear (Clause No.5.13.6.1)

o) LT SWITCHGEAR:

One number indoor type 415V LT switchgear is present in the Common Control Room for supply of 415 V (3 phases, 1 neutral and single phase for lighting etc). Provision of Space has been kept for extension of existing LT Panel. Supply installation and connection of these extension with Incomer (for new 100 kVA SAT) and Bus-coupler in the existing LT Switch Gear along with new Outgoing feeders.

C. TECHNICAL SPECIFICATION (CIVIL)

5.8 TECHNICAL SPECIFICATION FOR CIVIL JOB

5.8.1 MODULE MOUNTING STRUCTURE

5.8.1.1 SCOPE

This section covers activities related to Design, Manufacturing, Testing, Supply, Insurance, Transportation and Delivery at project site, Storage, Erection, testing of module mounting structure and anchoring the system.

The module mounting structure shall be installed over an appropriately designed modular and pre-fabricated flotation device with appropriate buoyancy to support the weight of at least one solar panel and one person per Mounting Structure.

Total designing and engineering for floating and anchoring technology to be provided by the module mounting structure manufacturer.

5.8.1.2 STANDARD

The PV module mounting structure must conform to the latest edition of any of the following IEC / equivalent BIS Standards for floater design qualification and type approval:

Sl. No.	Standards	Description
1	ASTM D1693	Test for Environmental Stress Cracking of HDPE
2	ISO16770	Stress cracking resistance of HDPE
3	IS 15410:2003	Test for drinking water compatibility, Material safe for drinking water
4	RoHS directive	Test for Restriction of Hazardous Substances

	2002/ 95/EC	
5	ASTM D5397	Standard Test Method for Evaluation of Stress Crack Resistance

5.8.1.3 TECHNICAL REQUIREMENTS

- ❖ The Module structure design shall be appropriate and innovative. It must follow the existing water profile.
- ❖ The structure shall be designed to allow easy replacement of any module and shall be in line with the site requirement.
- ❖ The floatation device should be manufactured from HDPE with UV stabilizer. The grade of HDPE used should have very good Environmental Stress Crack Resistance (ESCR) and a combination of hardness and impact strength (ASTM D5397, ASTM D1693).
- ❖ The floatation device should be passed the Full notch creep test (ISO16770).
- ❖ On the date of bid opening, the offered floatation device should be under operational for **last five years** at least in MWp scale floating PV project in a single installation in anywhere in the world(certification to be provided from owner of the project).
- ❖ The floater vendor should have proven solution for **Anchoring & Mooring** with at least **5 projects** commissioned worldwide and all those plants are grid connected on the date of Bid opening and supporting documents for that.
- ❖ The array structure shall be made of Aluminum alloy/ stainless steel SS 304 of suitable size.
- ❖ In general bolts, nuts, shims and other hardware should be Aluminium/stainless steel SS304. Fasteners visible outside shall be of Aluminium/stainless steel SS304.
- ❖ The floatation device used should be safe for use when in contact with drinking water and meet requirements stipulated in standard IS 15410:2003.
- ❖ The material of the floatation device would be UV stabilized for long time.
- ❖ The floatation device wall thickness should be Minimum - 3mm.

- ❖ The material used shall be halogen, silicon free conforming to RoHS directive 2002/95/EC
- ❖ The flotation device should be chemically resistant to acid, lye, petrol, and mineral oil & partially resistant to benzene.
- ❖ The flotation device material should pass the different HDPE material test from Central Institute of Plastics Engineering & Technology (CIPET) or reputed labs from India which may be inspected by the Purchaser.
- ❖ The flotation device, when installed in the raw water reservoir, should not restrict the process of gas exchange across the air water interface. In order to facilitate this, the design of the flotation device should be such that appropriate voids, greater than at least 30% of all area covered by the flotation device, are provided and form an integral part of the flotation device design.
- ❖ The flotation device should be designed such that it arrests evaporation and facilitates in evaporation loss mitigation. Vendor should provide appropriate cover by flotation device and solar panel and total coverage of water body should not more than 70% of the Raw Water Pond water body. Appropriate vapour escape vents should be provided for each flotation device and solar panel assembly for the purpose of maintaining BOD of the water body.
- ❖ The flotation device should be prefabricated and designed for simple mechanical on-site installation. There shall be no requirement of welding, masonry or complex machinery at the installation site.
- ❖ The flotation device should be modular, such that the installed assembly can be easily expanded and scaled up if required. Each module/combination of maximum two modules should support at least one solar panel. All modules should be standardized and independently created.
- ❖ Stability of floating device should be maintained, No color variation after UV exposure equivalent to 10 years under 150 kilo-Langley/year irradiation. Third party testing or witness is required by purchaser.
- ❖ Minimum strength safety factor for floating device at ambient temperature should be 1.15 on extreme conditions.
- ❖ The design of the flotation device should incorporate appropriately sized walking platforms for regular maintenance and inspection. Maintenance alleys should be for both column and row alleys. The row alleys platform

should have a continuous uninterrupted surface with the minimum width of at least 500 mm.

- ❖ Flexible mooring system shall be designed to keep the platform in position to adopt waves, wind and water level variation
- ❖ The flotation device should be re-processable and recyclable at the end of its useful life.
- ❖ The array structure shall be so designed that it will occupy minimum space without sacrificing the output from SPV panels.
- ❖ The structure shall be designed to allow easy replacement of any module by authorized personnel and shall be in line with the site requirements.
- ❖ The support structure, design shall normally be designed to withstand wind speed upto 200 kmph.
- ❖ The PV fixation system should pass the resistance upto 200 kmph wind speed.
- ❖ In order to address the proper handling of Panel mounting system during the severe weather conditions, floating vendor should have proper expansion capability for Panel mounting system.
- ❖ Big wind tunnel test for the structures in all wind directions (real scale, real angle) for at least 2x4 configurations to be done.
- ❖ The clearance between lowest part of the module structure and the water level shall normally not be more than 250mm.
- ❖ The module alignment and tilt angle, in case of floating SPV power plant, shall be between 1 degree to 18 degrees. It shall be mounted facing south and tilted to an angle within the range of 1 degree to 18 degrees for optimum performance and appropriate wind resistance that must be mentioned in engineering drawing for approval of WBPDCCL with documentary proof.
- ❖ Mountability of solar panel by the flotation device should be maximum 2 panels per unit.
- ❖ The flotation device should balance the thermal expansion so that PV Panel not stretched by thermal expansion.
- ❖ The flotation device should be manufactured locally only, to ensure safe work practise, genuine process is followed & transparent quality checks by WBPDCCL at manufacturing premises any time.

5.8.1.4 PERFORMANCE WARRANTY

The manufacturer should warrant the Module Mounting Structure and Anchoring system to be free from the defects and/or failures specified below for a period not less than **ten (10)** years from the date of sale to the original customer (i.e. EPC Contractor).

- iv. Defects and/or failures due to manufacturing
- v. Defects and/or failures due to quality of materials
- vi. Non conformity to specifications due to faulty manufacturing and/or inspection processes.

If the Solar Module Mounting Structure and Anchoring system fails to conform to this warranty, the manufacturer will replace the Solar Module Mounting Structure and Anchoring system, at the Purchaser's sole option.

The contractor has to submit the Warrantee Certificate issued by the Module mounting structure (Floater) Manufacturer to WBPDCCL against delivery of each lot. The Warrantee Certificate issued by the contractor must comprise order no. of WBPDCCL, name of the project and name of WBPDCCL.

The contractor should submit the warrantee certificate issued by the original Floater manufacturer to WBPDCCL after delivery of every lot. The warrantee shall include but not limited to the following:

- g) Capacity and model of the Floater,
- h) Floater serial no.
- i) Warrantee period: 10Yrs
- j) Name of WBPDCCL (as principal purchaser)
- k) Order reference of WBPDCCL
- l) Order reference & name of the of vendor.

5.8.1.5 APPROVAL

- Design, drawings, specifications of all components with material selected & installation details shall also be included with Detailed Design Report.
- Joint inspections and testing will be done by WBPDCCL and the authorized representatives of the contractor at the manufacturer's workshop on regular basis for quality assurance and testing. Acceptance Tests as per relevant Standard shall be carried out at the module Mounting Structure's workshop.
- Approval of the Engineer in charge should be taken before execution of the work at site.

The contractor shall deliver the product to the site only after receipt of such approval against their prayer in writing from WBPDCCL.

5.8.2 INVERTER CUM CONTROL BUILDING:

New Inverter cum Control Room building is required to be constructed for housing the electrical equipment/ panel, Inverters, Local Lighting panel, Local UPS cum-UPS DB, Fire Fighting System etc other daily requirements for the operation & maintenance of Solar Photovoltaic Power Plant. The building shall be constructed with conventional RCC framed structure with brick partition walls for equipments and operations room. Equipment room shall be designed as per the OEM recommendations to ensure desired life of equipment. Bidder shall furnish the drawing of the proposed buildings to the Employer for approval, prior to construction. The construction of the same shall be as under-

5.8.2.1 EQUIPMENT ROOM LAYOUT:

Flexibility shall be kept for handling of equipment without obstruction both during erection and maintenance. Adequate handling facilities, space, door/ rolling shutter of adequate width and height shall be provided for the purpose. The followings specification shall be followed for designing the Equipments cum Control Building:

- a) Minimum clearance between two switchgear panels, facing each other shall be maintained as 2200 mm. These distances shall be maintained for all other panels located inside the room.
- b) 33 kV Switchgear Front side and rear side shall be with minimum 3 mtrs and 2 mtrs gap from Wall/Panel. Each 33 kV Indoor switchgear shall be kept with a minimum one additional space to install one breaker on either side other than the specified requirement. Switchgear cum control room shall be provided with a Monorail arrangement with Hoist.
- c) Clearance from any obstruction like column, wall, and vertical raceway on back side of switchgears shall be maintained as 1200mm (minimum) for single front panel / 1500mm (minimum) for double front panel and shall also comply with manufacture's standard. Minimum Space between the sides of two switchgears or between any two panels or between switchgear and the wall shall be 1200 mm. Where access is not envisaged, clearance shall be 200 mm.
- d) All electrical room shall be provided with 2 doors in addition to the shutters provided for handling transformer, switchgear, panels etc.

- e) Switchgear room/MCC/Control room shall be pressurized above the atmospheric pressure to prevent ingress of dust.
- f) Switchgear/MCC room shall have a minimum clear height of 5 m above floor level. All electrical equipment shall be located above the highest flood level. Cable cellar room shall be located above around to prevent ingress of water inside.
- g) Control room shall be separated from switchgear /MCC room.

5.8.3 PV ARRAY O&M MAINTENANCE ARRANGEMENT

Equipments which are required for day to day cleaning of the solar panels and for O&M of the solar plant shall be in the scope of the bidders and accordingly the bidder has to provide all the necessary equipments, accessories, tool & tackles, boat, piping arrangement which as may be required for the same. Bidder shall have to provide a paddle boat for O&M operation with carrying capacity of four persons.

5.8.4 APPROACH ROAD FOR SOLAR POWER PLANT

Suitable approach road from Control Building to Solar Plant to carry safe and easy transportation of equipment and material at the project site shall be made. The road should provide easy and fast approach to each location of the plant. Roads are to be constructed with sufficient width (minimum 3.75m) followed by 0.5m well compacted shoulders on each side. The road must be well compacted as per the relevant IS standards and MORTH updated till date. All peripheral roads and pathways from central road to Inverter room road shall be WBM road. Also, all cable crossings and other crossings shall be provided with GI/ Hume pipes.

5.8.5 WATCHMEN / SECURITY CABIN

Contractor shall provide adequate numbers of prefabricated Watchman's portable cabin at each corner of Ponds (1, 2&4) and strategic locations surrounding of the plant. The Minimum size of watchmen's (Security Cabin) cabin is 1.2 metre x 1.8 metre size and height of 2.4m with appropriate roof at the top. Location of the watch Cabin (Security Cabin) will be as directed by the Purchaser. The Prefabricated Security Cabin of size 3 metre x 3 metre at the main entrance gate shall be designed and constructed by the Successful Bidder keeping in view the safety and security of the power plant.

5.8.6 TRANSFORMER YARD

Transformer Yard shall be constructed adjacent to each Inverter Cum control Room near each pond for installation of Inverter Transformer.

D. TECHNICAL SPECIFICATION FOR ELECTRICAL

5.9 SPECIFICATIONS FOR SUPPLY MATERIAL

5.9.1 PV MODULE:

5.9.1.1 SCOPE

This section covers activities related to design, manufacturing, testing at works, supply, insurance, transportation and delivery at Project site, storage, erection, testing, commissioning of solar modules as detailed hereunder.

- a. Solar Mono/ Poly crystalline modules having capacity minimum 325 Wp shall be used for the project for 5 MW Solar PV Power Plant each at Sagardighi Thermal Power Plant, Murshidabad. However the make, capacity, technical specification and the model no. of each module connected with an individual inverter should be the same.
- b. Total capacity of the Solar PV modules shall be designed to ensure 10 MW AC and the net minimum guaranteed generation mentioned in the **clause no. 3.33 of GCC** of this tender document.

The scope of supply shall also include spare modules (at least 100 Nos) required for any normal or breakdown maintenance and special tools & plants required for erection & maintenance for each project. Corresponding parts of all the equipments & spares shall be of the same specification & workmanship and shall be interchangeable. All the material & workmanship shall be of reputed make as have proven successful in their respective uses in similar services & under similar condition.

5.9.1.2 STANDARDS

The PV modules must conform to the latest edition of any of the following IEC / equivalent BIS Standards for PV module design qualification and type approval:

Sl. No.	Standards	Description
1	IEC: 61215/IS: 14286	Crystalline silicon terrestrial photovoltaic modules – Design qualification and type

		approval.
2	IEC: 61730 – Part 1	Photovoltaic (PV) module safety qualification – Requirements for construction.
3	IEC: 61730 – Part 2	Photovoltaic (PV) module safety qualification – Requirements for testing.
4	IEC: 61701/IS: 61701	Salt Mist Corrosion Testing of the module.
5	IEC: 62804	Test method for detection of Potential Induced Degradation of photovoltaic (PV) modules.

The proposed PV Module must have the Test Certificate issued from accredited test laboratories of Ministry of New and Renewable Energy, Government of India under off grid programme.

The test certificates issued from IEC accredited laboratories shall also be acceptable.

The manufacturers should get their samples tested as per the new format/ procedure which are effective from 1st April 2013 onwards as per MNRE, Govt. of India Guideline.

5.9.1.3 IDENTIFICATION AND TRACEABILITY

Each PV module must use a RF identification tag (RFID), which must contain the following information:

- i. Name of the manufacturer of PV Module
- ii. Name of the Manufacturer of Solar cells
- iii. Month and year of the manufacture (separately for solar cells and module)
- iv. Country of origin (separately for solar cells and module)
- v. I-V curve for the module
- vi. Peak Wattage, I_m , V_m and Fill Factor for the module
- vii. Unique Serial No and Model No of the module
- viii. Date and year of obtaining IEC PV module qualification certificate
- ix. Name of the test lab issuing IEC certificate
- x. Other relevant information on traceability of solar cells and module as per ISO 9000 series.

RFID for each solar module shall be provided inside or outside of the module and must be able to withstand environmental conditions and last the lifetime of the solar module as per MNRE norms which is effective from 1st April 2013.

5.9.1.4 AUTHORIZED TESTING LABORATORIES/ CENTERS

PV modules must qualify (test reports/ certificate from IEC/NABL accredited laboratory should be enclosed) as per the relevant IEC standard. Additionally the performance of PV modules at STC conditions must be tested and approved by one of the IEC / NABL Accredited Testing Laboratories including Solar Energy Centre (SEC).

5.9.1.5 PERFORMANCE WARRANTY

A. Material Warranty: The manufacturer should warrant the Solar Module(s) to be free from the defects and/or failures specified below for a period not less than Ten (10) years from the date of sale to the original customer (i.e. EPC Contractor).

- i. Defects and/or failures due to manufacturing
- ii. Defects and/or failures due to quality of materials
- iii. Non conformity to specifications due to faulty manufacturing and/or inspection processes.

If the solar Module(s) fails to conform to this warranty, the manufacturer will replace the solar module(s), at the Purchaser's sole option.

B. Performance Warranty: The manufacturer should warrant the output of Solar Module(s) for at least 90% of its rated power upto initial 10 years & 80% of its rated power upto 25 years from the completion of trial run at site/date of final commissioning.

The contractor has to submit both the Warranty Certificate issued by the module manufacturer to WBPDC against delivery of each lot. The Warrantee Certificate issued by the contractor must comprise order no. of WBPDC, name of the project and name of WBPDC.

The contractor should submit the warrantee certificate issued by the original PV Module manufacturer to WBPDC after delivery of every lot. The warrantee shall include but not limited to the following:

- m) Capacity and model of the PV module,
- n) PV Module serial no.
- o) Warrantee period
- p) Name of WBPDC (as principal purchaser)
- q) Order reference of WBPDC
- r) Order reference & name of the of vendor

Manufacturer of proposed PV modules must have the ISO 9001:2008 or ISO 14001 Certification for their manufacturing unit for their said manufacturing item.

Note: Only indigenously manufactured PV modules should be used in Grid Connected Floating Solar PV Power Plants under this scheme. However, other imported components can be used, subject to adequate disclosure and compliance to specified quality norms and standards and approval of the Purchaser.

5.9.1.6 PERFORMANCE RATIO OF THE PLANT

Performance Ratio of the plant calculated for any time period of measurement shall be minimum 75 %.

PR - Provisional Acceptance Test Verification Procedure

The Performance ratio test aims at the comparison of the actual PV plant energy production with the guaranteed value for a limited operation time of the PV plant of 30 consecutive days.

After Commissioning of the Plant and after receiving all the satisfactory results regarding the correct operation of the plant, there will be continuous monitoring of the performance for 30 days. This monitoring will be performed on the site under the supervision of the Purchaser / Purchaser's engineer.

The final tests to prove the guaranteed performance parameters shall be conducted at site by the Contractor in presence of the Purchaser. The Contractor's commissioning / start-up Engineer shall make the plant ready to conduct such tests. The Performance Guarantee Tests (PG tests) shall be commenced, within a period of one (1) month after successful Commissioning. Any extension of time beyond the above one (1) month shall be mutually agreed upon.

Performance Ratio of the plant will be calculated as per IS/IEC 61724: 1998 (Photovoltaic system performance monitoring - Guidelines for measurement, data exchange and analysis).

$$\text{Performance Ratio (PR)} = Y_A / Y_R [1 - \alpha * (T_{\text{Cell avg.}} - T_{\text{Cell}})]$$

Where;

Y_A = Final PV system yield (representing the number of hours that the system would need to operate at its rated output power P_{Nom} to contribute the same energy to the grid as was monitored)

Or, $Y_A = E_{ac} / P_{Nom}$

Y_R = Reference yield (representing the number of hours during which the solar radiation would need to be at STC irradiance levels in order to contribute the same incident energy as was monitored)

Or, $Y_R = I_{R Site} / I_{R STC}$

E_{ac} = AC energy injected into the grid during a clearly specified amount of time (kWh)

P_{Nom} = Installed nominal peak power of modules (Flash test rating at STC) (kWp)

I_{R Site} = Irradiation on the module plane of array during a clearly specified amount of time (measured with a Pyranometer installed on the array plane) (kWh/sq. m)

I_{R STC} = Irradiance at STC (kW/ sq. m)

T_{cell avg} = Average cell/ module temperature (°C)

T_{cell} = STC cell/ module temperature (°C)

α = temperature coefficient of power (negative in sign) corresponds to the installed module (%/°C)

Monitoring System for PR Verification

The following instrumentation will be used to determine the Solar Plant Performance:

- Power Meter at the delivery point.
- Power Meter for each inverter for reference only.
- One nos. calibrated pyranometer to determine irradiance on the plane of array (with a target measurement uncertainty of ± 2).
- One nos. calibrated pyranometer to determine irradiance on horizontal plane (with a target measurement uncertainty of ± 2)
- Two nos. thermocouples to measure module temperature with a measurement uncertainty of ±1 °C.
- Shielded ventilated thermocouple with a measurement accuracy of ±1°C.

- An anemometer mounted on a 10m mast to measure wind speed (without additional shadowing on modules).

During the comprehensive O&M period after commissioning, PR shall be tested in yearly basis considering 100% grid availability. However, WBPDC may check the PR at any time of the year for a period of minimum 7 days.

5.9.1.7 TECHNICAL REQUIREMENTS

- Modules should be Poly crystalline type having capacity of minimum 320 Wp. Higher capacity Solar PV modules will be preferred. (more than 320 Wp).
- The module frame shall be made of aluminium or corrosion resistant material, which shall be electrically compatible with the structural material used for mounting the modules. Grounding / Earthing provision shall be provided.
- Solar module shall be laminated using lamination technology using established polymer (EVA: Ethylene-vinyl acetate).
- The back sheet used in the crystalline silicon based modules shall be of 3 layered structures. Outer layer of fluoropolymer, middle layer of Polyester (PET) based and Inner layer of fluoropolymer or UV resistant polymer. Back sheet with additional layer of Aluminium also will be considered. The thickness of back sheet should be of minimum 300 microns with water vapour transmission rate less than 3g/m²/day. The Back sheet shall have voltage tolerance of more than 1000 V.
- The EVA used for the modules should be of UV resistant in nature. No yellowing of the back sheet with prolonged exposure shall occur.
- The sealant used for edge sealing of PV modules shall have excellent moisture ingress protection with good electrical insulation (Break down voltage >15 kV/mm) and with good adhesion strength.
- The solar modules shall have suitable encapsulation and sealing arrangements to protect the silicon cells from the environment. The arrangement and the material of encapsulation shall be compatible with the thermal expansion properties of the Silicon cells and the module framing arrangement/material. The encapsulation arrangement shall ensure complete moisture proofing during the whole life of the solar modules.
- The Module shall be made of high transmittance glass front surface giving high encapsulation gain. The glass used to make the crystalline silicon

modules shall be toughened low iron glass with minimum thickness of **3.2 mm**. The solar cell shall have surface anti-reflective coating to help to absorb more sunlight in all weather conditions. The glass used shall have transmittance of above 90% and with bending less than 0.3% to meet the specifications.

- Module rating is considered under standard test conditions, however Solar Modules shall be designed to operate and perform as per installation site condition.
- The peak-power point voltage and the peak-power point current of any supplied module and/or any module string (series connected modules) shall not vary by more than 2 % (two percent) from the respective arithmetic means for all modules and/or for all module strings, as the case may be.
- All materials used shall be having a proven history of reliable, light weight and stable operation in external outdoor applications and shall have service life of 25 years.
- The modules should be 100% PID (Potential Induced Degradation) tolerant and should comply with IEC 62804.
- Solar PV Module design shall conform to following requirement:
 - Weather proof DC rated MC connector and a lead cable coming out as a part of the module, making connections easier and secure, not allowing for any loose connections.
 - Resistant of water, abrasion, hail impact, humidity & other environment factor for the worst situation at site.
 - The PV Junction Box shall confirm IP 65 and shall have sufficient bypass diodes to avoid shadowing effects.
- Modules shall perform satisfactorily in relative humidity up to 95% and temperature between -10°C and 85°C (module temperature).
- The PAN file of the solar module should be validated by Third party.
- The developer shall arrange for the details of the materials along with specifications sheets of from the manufacturers of the various components used in solar modules along with those used in the modules sent for certification. The Bill of materials (BOM) used for modules shall not differ in any case from the ones submitted for certification of modules.

- The I-V characteristics of all modules as per specifications to be used in the systems are required to be submitted at the time of supply.
- SPV module shall have module safety class-II and should be highly reliable, light weight and must have a service life of more than 25 years.

5.9.1.8 SPECIFICATION OF THE PV MODULES

Desired specification of the PV Module shall be as mentioned hereunder:

SI. No.	Item	Description
1	Type	Crystalline Silicon - Poly
2	Efficiency of module	Minimum 15 % at STC
3	Cell efficiency	Minimum 17 % at STC
4	Fill Factor	Minimum 73 %
5	No. of cells per module	atleast 72
6	Module Frame	Non-corrosive and electrolytically compatible with the structural material, preferably anodized Aluminium.
7	Termination box	Thermo-plastic, IP 65, UV resistant
8	Blocking diodes	Schottky type
9	Bypass Diode	Yes, as required
10	Power Rating	The nominal power of a single PV module shall be minimum 250 Wp
11	Power tolerance	upto +5 %
12	Temperature co-efficient of power	Less than - 0.50% / °C
13	Glass	High transmittance glass with Anti Reflective Coating (ARC)
14	RF Identification tag for each solar module	Shall be provided inside or outside the module and must be able to withstand environmental conditions and last the lifetime of the solar module as per MNRE Norms.

5.9.1.9 APPROVAL

- The Detailed Design Report Submitted by the contractor to WBPDCCL must contain but not limited to the following details of the solar modules:
 - Detailed specification
 - Necessary Drawings
 - Type Test Report and Necessary Certificates etc.
- Inspection of Electro Luminescence (EL) & Potential Induced Degradation (PID) tests during manufacturing of solar PV modules may be carried out by WBPDCCL.
- Joint inspections and testing will be done by WBPDCCL and the authorized representatives of the contractor at the manufacturer's workshop on regular basis for quality assurance and testing. Acceptance Tests as per relevant Indian Standard shall be carried out at the module manufacturer's workshop. Following tests as per relevant Indian Standard shall be carried out on certain number of modules from a lot (decided by WBPDCCL) as acceptance tests of Solar PV Modules:
 - Visual Inspection
 - Thermal cycling test
 - Damp heat test
 - Performance Test of the modules at STC and NOCT with Sun Simulator of Class B or better as per Indian Standard
 - Performance Test of the modules at low irradiance (200 W/m²) with Sun Simulator of Class B or better as per Indian Standard
 - Dielectric withstand test
 - Continuity and leakage current test
 - Insulation Resistant test
 - Wet leakage current test
 - Potential induced degradation test
 - Mechanical load test
 - Solar cells: Cell tester.
 - EVA: Gel content test and pressure cooker test.
 - Glass: Fragmentation test
 - Frame: Frame anodizing test
 - Junction box: IP 65 test.
 - Ribbon: Elongation test and camber test.
 - RTV Silicone sealant: Adhesiveness test.

- Electroluminescence test to detect micro cracks.
- Ammonia test for anti-corrosion
- Any other test as desired by WBPDCCL

Arrangements for the aforesaid testing and inspection at manufacturer's end are to be provided by the contractor.

- Prior to the delivery of the product, the contractor shall submit but not limited to the following documents:
 - Guarantees
 - Instructions for installation and operation manual
 - Test reports for routine tests and acceptance tests etc.
- The contractor shall deliver the product to the site only after receiving such approval against their prayer in writing from WBPDCCL.
- WBPDCCL may select certain number of modules delivered at site by the contractor on random basis for conducting performance test of those modules from any accredited test laboratory of MNRE/NABL. If there are any discrepancy found in the test results and the values specified by the contractor, the contractor will be bound to accept the decision made by WBPDCCL in respect of taking further course of action.

5.9.1.10 ACCEPTANCE CRITERIA:

- Each module is to be tested for electro luminescence test (on site) to detect micro cracks and pass the test as per IEC norms and also record of data on the test for each module will be done by WBPDCCL for future studies. Contractor has to co operate at site.
- 25 no modules to be carried out NISE, Delhi or any NABL or MNRE accredited test centers.
- For the above (i.e.25 no modules) special packing if required may be done to shift the panels from manufactory site to testing lab as directed by WBPDCCL.
- Sufficient competent man power to be deployed at test centre for sufficient days to unpack and repack the modules after the test.
- Contractor has to coordinate with WBPDCCL for all the testing activity.

- 1no. module from each batch of production will be tested for PID (1000V) & LID test also need to be carried out test and results should be submitted to WBPDC.

5.9.2 GRID CONNECTED INVERTERS

5.9.2.1 SCOPE

This section covers the activities related to design, manufacturing, testing at works, supply, insurance, transportation and delivery at project site, storage, erection, testing, commissioning of Solar Inverters/Power Conditioning Unit (PCU) as detailed hereunder.

- Adequate number of Indoor Solar Central Inverter of minimum capacity 500 kW having high quality, high efficiency and reliable operation. Total inverter capacity of the plant should not be less than 10000 kW(AC).
- The scope of supply shall also include necessary spares, if any, required for normal or any breakdown maintenance for at least 05 (five) years and special tools & plants required for erection & maintenance. Corresponding parts of all the equipments & spares shall be of the same specification & workmanship and shall be interchangeable.

All the material & workmanship shall be of reputed make as have proven successful in their respective uses in similar services & under similar condition.

The solar inverter/power conditioning unit shall be suitable for interfacing with SCADA system and all necessary transducers shall be included under the scope of supply.

5.9.2.2 STANDARDS

The equipments and materials covered by this specification shall conform to the latest edition of following Indian Standards or equivalent IEC standards except where specified otherwise in this specification:

Sl. No.	Standards	Description
1	IEC/IS: 61683	Photovoltaic systems – Power Conditioners – Procedure for measuring efficiency
2	IEC 62093	Balance-of-system components for photovoltaic systems – Design qualification natural environments
3	IEC 60068	Environmental Testing
4	IEC 62116 / IEEE 1547/UL 1741/ equivalent IS standard	Islanding Prevention Measurement
5	IEC 61727 Relevant CEA/	Interfacing with utility grid

	CERC regulation and grid code (amended up to date)	
6	IEC 61000 series	EMC, harmonics, etc.
7	IEC 62109 (1&2), EN 50178 or equivalent	Electrical safety
8	IEC 62093 or equivalent	Reliability test standard

Solar Inverters should have certificate and approval from VDE, IEC etc. The inverters should have CE conformity according to LVD (Low Voltage Directive) and EMC (Electro Magnetic Compatibility) Directive for safety purpose.

Type test certificate issuing authorities should be any NABL/IEC Accredited Testing Laboratories or MNRE approved test centres.

Equipment meeting with other authoritative standards which ensure an equal or better quality is also acceptable. Where the equipment conforms to any other authoritative standard, the salient points of difference between the standard adopted and IS/IEC shall be clearly brought out by the contractor.

5.9.2.3 TECHNICAL REQUIREMENTS

- The inverter should be 3- Φ static solid state type power conditioning unit.
- Inverter/PCU shall be centralized grid tied in nature, shall consist of MPPT controller. Inverter shall be selected based on array design. Associated control and protection devices shall be an integrated part of the PCU.
- Degree of protection of the indoor Inverters shall confirm at least IP-42.
- The inverters shall be built in with data logging system for remote monitoring of the plant performance through external PC. (PC shall be provided as a part of the Solar PV Plant).
- The dimension, weight, foundation details etc. of the PCU shall be clearly indicated in the technical specification to be submitted with the detailed design report.
- The PCU shall be capable of complete automatic operation, including wake-up, synchronization & shut down independently & automatically. Inverters / PCU shall operate in sleeping mode when there will no power connected.
- The Inverter shall have internal protection arrangement against any sustained fault in output line and lightning in the grid. AC protection boxes shall be provided at the inverter output which shall include over current, under voltage protection etc.

- Both AC & DC lines shall have suitable fuses & surge arrestors and contactors to allow safe start up and shut down of the system.
- PCU shall be capable to synchronize independently & automatically with grid power line frequency to attain synchronization and export power generated by solar plant to grid.
- Inverters shall have the features like Low Voltage Ride through (LVVRT), High Voltage Ride through (HVVRT) etc. for grid support and connection.
- Inverters should run in synchronized manner, effect of one inverter should not be reflected to the others. The PCU shall be capable of operating in parallel with the grid utility service and shall be capable of interrupting fault line currents, line to ground fault currents and short circuit currents.
- The PCU shall be able to withstand an unbalanced load conforming to related IEC standard (+/- 5% voltage). The PCU shall include appropriate self-protective and self-diagnostic features to protect itself and the PV array from damage in the event of PCU component failure or from parameters – beyond the PCU's safe operating range due to internal or external causes. The self-protective features shall not allow signals from the PCU front panel to cause the PCU to be operated in a manner which may be unsafe or damaging. Faults due to malfunctioning within the PCU, including commutation feature, shall be cleared by the PCU protective devices and not by the existing site utility grid service circuit breaker.
- Operation outside the limits of power quality as described in the technical data sheet should cause the power conditioner to disconnect the grid. Additional parameters requiring automatic disconnection are over current, earth fault, short circuit and reverse power.
- The inverter itself shall consist of one circuit breaker for isolation from the circuit during any fault or maintenance purpose.
- The inverters shall operate satisfactorily within the operating ambient temperature range of -15°C to +60°C. The contractor shall assure that the inverter should not de-rate upto 50°C ambient temperature.
- To take care of PID (Potential Induced Degradation), the inverters should have active negative grounding kit.
- Following protections shall be provided with the inverter.
 - Over voltage both at input & output

- Over current both at input & output
 - Over/under grid frequency
 - Heat sink over temperature
 - Short circuit
 - Protection against lightning
 - Surge arrestors to protect against Surge voltage induced at output due to external source
 - Direct earth fault protection and body earthing
 - Set point pre-selection for VAR control
 - Any other protections required
- Inverters should have user friendly LED/LCD or touch display for programming and view on line parameters such as:
 - Inverter per phase Voltage, current, kW, kVA, frequency and power factor.
 - 15 minute, Daily, monthly & Annual energy generated by the solar system(kWh)
 - Solar system temperature
 - Ambient temperature
 - Grid Voltage, frequency and power factor
 - AC and DC side voltage and current
 - Power factor on AC side
 - DC injection into the grid
 - Inverter Import export kWh summation
 - Solar kWh summation
 - Inverter ON/OFF
 - Grid ON/OFF
 - Inverter under voltage/over voltage
 - Inverter over load
 - Inverter over temperature etc.
 - Total Current Harmonics distortion in the AC side
 - Total Voltage Harmonic distortion in AC side
 - Efficiency of the inverter
 - Solar system efficiency
 - Display of I-V curve of the solar system
 - Fault details with time when occur.
 - Any other parameter considered necessary by supplier of the solar PV system based on prudent practice.

5.9.2.4 SPECIFICATION

SI. No.	Operating Parameter	Desired specification
1	Input (DC)	
	PV array connectivity capacity	As per site requirement
	MPPT Voltage range	Compatible with the array voltage
	Number of MPPT Channel	Number of MPPT channel shall be minimum one. One spare MPPT channel shall be provided.
2	Output (AC)	
	Nominal AC Power output	500 kW (minimum)
	Number of Grid Phase	3
	Adjustable AC voltage range	+/- 10%
	Frequency range	+/- 5%
	AC wave form	Sine wave
	THD	Less than 3%
	Switching	H.F. transformer/transformer less
3	General Electrical data	
	Maximum Efficiency	97.5 % (minimum)
	VAR Control	Optional
	No load loss	< 1% of rated power
	Maximum loss in sleep mode	< 0.05% of rated power
4	Protection	
	DC Side	As mentioned in the Technical Requirement
	AC side	As mentioned in the Technical Requirement
	Isolation Switch	PV array Isolation switch (DC)
	Ground fault detection device (RCD)	To be provided
5	Display	
	Display type	LED/LCD or touch display
	Display parameter	
	DC	As mentioned in the Technical Requirement
	On grid connected mode	As mentioned in the Technical Requirement
9	Interface (Communication protocol)	Suitable port must be provided in the inverter for i. On site upgrade of Software ii. On site dumping data from the memory iii. Plant based remote monitoring system
10	Storage of Data	At least for 1 year. Separate data logger may be provided to meet the criteria.
11	Monitoring	Matched with the monitoring and data logging system (SCADA)
12	Mechanical Data	

SI. No.	Operating Parameter	Desired specification
	Protection Class	As mentioned in the Technical Requirement
	DC Switch	Integrated
	Operating ambient temperature	-15° C to 60° C
	Relative Humidity	15 to 95 %
	Noise Emission	Less than 80 dB (A) @ 1 meter
	Cooling	Forced cooling

5.9.2.5 Communication interface

The project envisages a communication interface which shall be able to support:

- Real time data logging
- Event logging
- Supervisory control
- Operational modes
- Set point editing

5.9.2.6 COMMUNICATION SYSTEM

Communication System shall be an integral part of inverter. All current values, previous values up to 40 days and the average values of major parameters shall be available on the digital bus.

5.9.2.7 DATA LOGGER SYSTEM

Data logger system (Hard ware) and the software for study of effect of various environmental & grid parameters on energy generated by the solar system and various analyses would be required to be provided.

The communication interface shall be suitable to be connected to local computer and also remotely via the Web using either a standard modem or a GSM / WIFI modem.

All the soft and hard data shall be connected from different Inverter cum control of this package to the SCADA of existing Control room near Raw Water Pond-3 through FO cable. Entire supply of cable and accessories, laying, termination / hookup, configuration, commissioning & display of entire soft data at the existing OWS at the existing BHEL server shall be under bidder scope.

5.9.2.8 WARRANTEE

The contractor should submit the warrantee certificate issued by the original inverter manufacturer to WBPDCCL after delivery of every lot. The warrantee shall include but not limited to the following:

- (i) Capacity and model of the inverter,
- (ii) Inverter serial no.
- (iii) Warrantee period
- (iv) Order reference of WBPDCCL
- (v) Order reference & name of the vendor
- (vi) Name of WBPDCCL (principal purchaser)

The warranty certificate as issued by the Inverter manufacturer, must comply the terms of the tender warranty period.

5.9.2.9 APPROVAL

The Detailed Design Report Submitted by the contractor to WBPDCCL must contain but not limited to the following details of the Solar Inverter/Power conditioning Unit:

- Detailed technical description of the complete unit
- Necessary Drawings
- Type Test Report etc.

Joint inspections and testing will be done by WBPDCCL and the authorized representatives of the contractor at the manufacturer's workshop on regular basis for quality assurance and testing. Acceptance Tests as per relevant Standard shall be carried out at the module manufacturer's workshop. Following tests shall be carried out on certain number of Inverters from a lot (decided by WBPDCCL) as acceptance tests of Solar Inverters:

- Visual Inspection
- Performance Test and measurement of AC & DC parameters
- DC reverse polarity protection
- Islanding Protection
- Over Voltage & Under Voltage withstand
- Over Frequency & Under Frequency withstand
- Night consumption
- Any other test as desired by WBPDCCL

Arrangements for the aforesaid testing and inspection at manufacturer's end are to be provided by the contractor.

Prior to the delivery of the product, the contractor shall submit but not limited to the following documents:

- Guarantees
- Instructions for installation and operation, manual
- Safety precautions
- Test reports for routine tests and acceptance tests etc.

The contractor can deliver the product to the site only after receiving such approval against their prayer in writing from WBPDCCL.

5.9.2.10 Acceptance:

- a) Factory tested for routine & type as per IEC norms in the presences of WBPDCCL staff along with warranty & guarantees certificates.
- b) The supplied inverters should have weighted average efficiency under Indian conditions be minimum 93% and minimum input power under Indian conditions should be above 85%.

5.9.3 PV ARRAY

Desired specification of the PV Array shall include but not limited to the following:

Sl No	Item	Description
1.0	PV Module interconnection connector	MC-4 / Tyco
2.0	PV Module interconnection cable and array cable	PV 1-F standard /NEC standard "USE-2 or RHW-2" type (double insulated)
3.0	PV array String Voltage	Compatible with the MPPT Channel of the inverter

5.9.4 STRING MONITORING BOX (SMB)

5.9.4.1 SCOPE

This section covers activities related to design, manufacturing, testing at works, supply, insurance, transportation and delivery at Project site, storage, erection, testing, commissioning of array junction box as detailed hereunder.

- a. Adequate number of String Monitoring Boxes shall be provided for termination of array string with inverter.
- b. The number and specification of PV String Monitoring Box will be as per plant configuration.

The String Monitoring Boxes shall be suitable for interfacing with SCADA system and all necessary transducers shall be included in the scope of supply.

5.9.4.2 STANDARDS

The String Monitoring Boxes shall conform to the latest edition of following Standards except where specified otherwise in this specification:

Sl. No.	Standards	Description
1	IS 13703: Part 1	Low voltage fuses for voltage not exceeding 1000V AC or 1500V DC: General Requirements
2	IEC 60269: Part 4 /IS 13703: Part 4	Low-voltage fuses: Supplementary requirements for fuse-links for the protection of semiconductor devices
3	IEC 60269-4: Part 6	Low-voltage fuses: Supplementary requirements for fuse-links for the protection of solar photovoltaic energy systems
4	VDE 0636	Low-voltage fuses

Equipment meeting with other authoritative standards which ensure an equal or better quality is also acceptable. Where the equipment conforms to any other authoritative standard, the salient points of difference between the standard adopted and IS/IEC shall be clearly brought out in the tender. Complete set of documents and standards in English shall be supplied by the bidder without any extra charge. It shall, however, be ensured that equipment offered comply with one consistent set of standards except in so far as they are modified by the requirement of this specification.

5.9.4.3 TECHNICAL REQUIREMENTS

- The junction Boxes shall have suitable arrangement for the followings (typical):
 - Combine groups of modules into independent charging sub-arrays that will be wired into the controller.
 - Provide arrangement for disconnection for each of the groups.
 - Provide a test point for each sub-group for quick fault location finding.
 - To provide group array isolation.
- The string monitoring box shall be dust, vermin, and waterproof and made of Polycarbonate Plastic.
- The string monitoring box shall be of IP 65 or better.

- The terminal will be connected to bus-bar arrangement of proper size. The junction boxes shall have suitable cable entry points fitted with cable glands of appropriate sizes for both incoming and outgoing cables.
- Suitable markings shall be provided on the bus-bars for easy identification and Cables shall be fitted at the cable termination points as per appropriate polarity.
- Each String shall be terminated through Fuses of required current rating
- The string monitoring box shall be provided with suitable Surge Protection Device (SPD).

5.9.4.4 APPROVAL

The Detailed Design Report Submitted by the contractor to WBPDC must contain but not limited to the following details of the String Monitoring Boxes:

- Detailed specification
- Necessary drawings etc.

Prior to the delivery of the product, the contractor shall submit but not limited to the following documents:

- Guarantees
- Instructions for installation and operation, manuals
- Necessary test certificates

The contractor shall deliver the product to the site only after receiving such approval against their prayer in writing from WBPDC.

5.9.5 THREE WINDING TRANSFORMER

5.9.5.1 SCOPE:

This section covers the activities related to design, manufacturing, testing at works, supply, insurance, transportation and delivery at Project site, storage, erection, testing, commissioning of step up transformers and associated equipments as detailed hereunder.

- a. One number of 3- Φ , three winding, oil filled, ONAF/ONAN type cooled transformers per pond with suitable capacity (not less than 10% higher margin as per NIT) shall be provided to step up voltage from 3- Φ , Grid tied Solar Inverter output to 33 kV voltage level for feeding the generated power to the 33 kV switchyard.
- b. Two LV winding of the three winding transformer will be connected to the outputs of two inverters and the HV sides will be connected to the 33 KV line through

VCB, Isolator etc. Three winding transformer will be Oil Type and placed outside of each local Inverter cum control room.

- c. Supply, laying, termination, testing, charging of 33/36 kV grade cable from respective Transformer Yard to existing 33 kV switchgear at Control room near Raw Water Pond no.3. The said 33 kV cable shall be terminated at new extension panel supplied under this package (Refer Single Line Diagram).

The scope of supply shall also include necessary spares required for normal operation & maintenance of transformers for a period of 5 (five) years & special tools & plants required for erection & maintenance. Corresponding parts of all the equipments & spares shall be of the same material & dimensions, workmanship & finish and shall be interchangeable. All the material & workmanship shall be of suitable commercial quality as have proven successful in their respective uses in similar services & under similar condition.

The transformers and associated equipment shall be suitable for interfacing with SCADA system and all necessary transducers shall be included in the scope of supply.

5.9.5.2 STANDARDS

The equipments and materials covered by this specification shall conform to the latest edition of following Indian Standards or equivalent IEC standards except where specified otherwise in this specification:

Sl. No.	Standards	Description
1	IS: 2026 (Part I to IV)/IEC 76	Power Transformer
2	IS: 2099/IEC 137	Transformers bushings
3	IS: 2705/IEC 185	Current transformers
4	IS: 335	Transformer oil
5	IS: 3637	Gas and oil operated relay
6	IS: 5120	Fittings and accessories for power transformers
7	IS: 6088	Dimensions for porcelain transformer bushings
8	IS: 3347	Loading guide for oil-immersed transformers
9	CBIP No. 295	CBIP Manual on Transformers Publication

Equipment meeting with other authoritative standards which ensure an equal or better quality is also acceptable. Where the equipment conforms to any other authoritative standard, the salient points of difference between the standard adopted and IS/IEC shall be clearly brought out in the tender. Complete set of documents and standards in English shall be supplied by the contractor without any extra charge. It shall, however,

be ensured that equipment offered comply with one consistent set of standards except in so far as they are modified by the requirement of this specification.

5.9.5.3 TECHNICAL REQUIREMENTS

The transformers shall be three winding, ONAF/ONAN, oil filled, 3- Φ , Step Up transformers.

Sl. No.	Standards	Description
1	Type	Three Winding
2	No. of phases	Three
3	Installation	Outdoor on rails
4	Rated continuous MVA at maximum ambient temperature of 40°C	As required according to Solar Inverter capacity
5	% Impedance at 75°C, rated current & frequency	As per relevant Indian Standard
6	Type of cooling	ONAN/ONAF
7	Winding material	Copper
8	Connection	
	HV	Delta
	LV	Star-Star
9	Vector group	YNy11y11 or as per system requirement
10	Voltage	
	HV	33 kV
	LV	As per Solar Inverter Output Voltage
11	Rated Frequency	50 Hz
12	Type of Bushing	
	HV Winding	Porcelain/ XLPE bushing
	LV Winding	Porcelain bushing
13	Insulation level (impulse withstand)	
	HV	170kV (Peak)
	LV	NA
14	Insulation level (Power freq. withstand)	
	HV	70 kV (rms)
	LV	3 kV (rms)
15	Tapping	OCTC
	Range	+5% to -5% @ 2.5%
16	Temperature rise of oil/winding over design ambient temperature of 50°C	50°C / 55°C
17	Hot spot temperature over a maximum yearly weighted average ambient temperature of 32 °C	105°C
18	Short circuit current for 1 sec. on HV side	25 kA

Sl. No.	Standards	Description
19	Short circuit withstand time	2 sec
20	Insulation	
	HV winding	Class B (Winding insulation shall be able to withstand 33 kV continuously)
	LV winding	Class B (Uniformly insulated)
21	Voltage withstand capacity during sudden disconnection of load	1.4 times the rated voltage for 5 sec. 1.25 times the rated voltage for 1 min. 1.1 times the rated voltage for continuous operation.
22	Noise level	< 90 dB As per NEMA TR-1 standard
23	Cooling medium	Mineral oil (as per IS 335)
24	Earthing	LV neutrals solidly earthed through neutral CT, HV side should also be earthed.
25	Minimum efficiency	98%

5.9.5.4 DESIGN CRITERIA

- The rating of the Transformers shall be sufficient to evacuate generated power from the Solar Inverter under full load conditions. The Transformers shall be able to evacuate generated power under all conditions of ambient temperature, frequency and voltage variations.
- The transformers will have Off Circuit Tap Changer (OCTC) with tap ranging +5% to -5% in steps of 2.5 % at HV side. The transformers will operate without injurious heating at the rated capacity at any voltage within +/-10% of the rated voltage of that particular tap. The transformer will be designed to deliver rated MVA continuously even at the lowest tap without exceeding specified temperature rise.
- HV line terminals shall be brought out through 33 kV class weather proof shaded porcelain bushing.
- Ambient air temperature for the transformer
 - Maximum ambient air temperature: 50° C
 - Maximum daily average ambient air temperature: 40° C
 - Maximum yearly weighted average ambient air temperature: 32° C
 - Minimum ambient air temperature: - 5° C
- The transformer shall be capable of withstanding the short circuit stresses 25 KA due to a terminal fault on one winding with full voltage maintained on the other winding for minimum period of two (2) seconds. This capability shall be demonstrated by type test report.
- Neutral Grounding Resistor (NGR) (if applicable):

- The resistor element shall be made of non-aging stainless steel having high electrical resistivity and low temperature co-efficient of resistant. Group of resistor elements shall be mounted together between end plates to form a bank. Banks are then to be connected in series-parallel combination to provide the current and ohmic value required. Adjacent banks shall be insulated from each other and the metal frame.
- Each neutral grounding resistor shall have structural work enclosed on all sides and also on top by sheet steel. Suitable ventilating louvers shall be provided on sides to ensure proper ventilation. The louvers shall be provided with fine wire mesh to make it vermin proof. Protection class shall be IP55 or better.
- Each cubicle shall be complete with two (2) nos. ground pads, tapped holes and bolts suitable for connection of 75 x 10 mm galvanised steel flats.
- Transformer neutral shall be grounded through NGR. The Neutral Grounding Resistor (NGR) shall be used for non-effective grounding of HV System of the plant. NGR shall be connected between the equipment neutral point and earth.
- Neutral Grounding Resistor shall be used to limit the magnitude of earth fault current so that damage of Electrical equipment is reduced, safety of personnel is increased and sensitive / selective earth fault protection can be provided.
- The transformers will be capable of being loaded in accordance with IS 3347 - loading guide for oil immersed power transformers. The transformers shall also be designed for operation at unbalanced loading conditions.
- The transformers shall be suitable for co-ordination and integration with SCADA System and necessary contacts and/or ports for the purpose shall be provided.
- Earthing arrangement of the transformers shall be provided as per the relevant Indian Standard.
- Necessary protection arrangement should be provided in the transformer.
- Construction of different parts of the transformer shall conform to the latest edition of IS 2026.
- Fittings and accessories as per relevant Indian Standard shall be provided within the scope of the work.
- Oil pit with sump pump arrangement to be provided if oil capacity of the transformer is more than 2000 l. Capacity of oil pit shall be minimum 1.25 times of total oil capacity of transformer.

- **Insulating oil**

- The transformer shall be filled with mineral insulating oil suitably inhibited to prevent sludging.
- First filling of oil along with 10% excess shall be furnished for each transformer. Oil shall be supplied in non-returnable containers suitable for outdoor storage.
- Oil preservation shall be by means of bellows/ diaphragm sealed conservator tank with silica gel breather to avoid direct connection between atmosphere and transformer oil. It shall be complete with level gauges, pipes, drain valve, buchholz relay with shut-off valves at both sides etc. The level gauges shall be so placed that same can be readable standing from ground. Necessary device shall be kept to provide annunciation in the event of rupturing of bellow.

- **Marshalling box:**

- A sheet steel, weatherproof, IPW55, marshalling box shall be provided for the transformer. The box shall contain all auxiliary devices except those which must be located directly on the transformer.
- All terminal blocks for cable connection shall be located in this box.
- The marshalling box shall be provided with cubicle lamp with door switch, space heater with thermostat and removable cable gland plate.

5.9.5.5 APPROVAL

The Detailed Design Report Submitted by the contractor to WBPDC must contain but not limited to the following details of the transformers:

- Detailed specification including Fittings and Accessories
- Necessary Drawings shall contain but not limited to the following:
 - Outline dimension drawings of transformers and fittings/accessories
 - Assembly drawings and weight of main components.
 - Transport drawings, showing main dimensions and weight of each package.
 - Foundation details
 - Tap-changing equipment
 - Name-plate diagrams
- Necessary test certificates and type test reports.

A joint inspection and testing will be done by WBPDC and the authorized representatives of the contractor at the manufacturer's workshop. Testing and inspection of the transformers will be carried out as per relevant Indian Standard.

Arrangements for the aforesaid testing and inspection at manufacturer's end are to be provided by the contractor.

Prior to the delivery of the product, the contractor shall submit but not limited to the following documents:

- Guarantees
- Instructions for installation and operation, manual
- Safety precautions
- Test reports for routine tests and acceptance tests etc
- Detailed schematics of all power instrumentation and control equipment and subsystems along with their interconnection diagrams. Schematics shall indicate wiring diagrams, their numbers and quantities, type and ratings of all components and subsystems etc.

The contractor can deliver the product to the site only after receiving such approval against their prayer in writing from WBPDC.

5.9.6 33kV INDOOR SWITCHGEAR & POWER EVACUATION

5.9.6.1 SCOPE

Proposed plant site is at SgTPP and evacuation voltage level is 33kV. This specification covers the design, manufacture, testing at manufacturer's works before dispatch, supply, delivery at site, transit insurance, storage at site, erection, testing & commissioning of 36KV, 3 phase, 50 Hz air insulated Metal clad indoor VCB type switchgear & Power Evacuation System unit with horizontal draw out horizontal isolation circuit breaker as per IS 13118 (1991)/IEC-60056 and other standards for satisfactory operation of 10 MW Solar PV Power Plant in SgTPP, Sagardighi, Murshidabad, West Bengal though **the bus bar capacity of the existing 33kV switchgear is capable of handling 20MW power.**

Corresponding parts of all the equipments & spares shall be of the same material & dimensions, workmanship & finish and shall be interchangeable. All the material & workmanship shall be of suitable commercial quality as have proven successful in their respective uses in similar services & under similar condition.

The design of the switchgear shall be based on safety to personnel and equipment during operation and maintenance, reliability of service, ease of maintenance, mechanical protection of equipment, interchangeability of equipment and ready addition of future loads.

Power shall be evacuated through existing 33 kV Switchgear installed at common Control Room for Floating Solar near Raw Water Pond No.3. The technical details of the said switchgear are mentioned in this specification.

The details of the equipments present in the existing switch gear are described in the clause no.

Bidders shall supply the following equipments for extension of the existing switchgear for the evacuation of 10MW power. Bidder shall supply at least **six** number 33 kV VCB panels of similar type, rating and make of present existing 33 kV switchgear complete with all accessories. All new 33 kV panels shall be installed and successfully connected and charged with existing power Bus, control bus on both the side of Bus-section, maintaining load balance. Necessary space provision is kept for this panel extension. The following equipments shall be supplied for the extension of the existing 33kV switchgear:

a. 33kV incoming feeder:

Three(3) no 33kV outgoing feeder from Inverter Transformer of pond no.1, 2 & 4 Floating Solar plant shall be supplied as incomer of 33kV Switchgear

Supply, laying, termination and charging etc of cable 33kV grade shall be done from the outgoing feeder from Inverter Transformer to the incoming feeder 33kV Switchgear. Distance from Inverter Control Room to 33 kV Switchgear shall be different for different feeder. However bidder shall evaluate the distance during detail engineering. Details of the cable laying route and specification given in the clause no._5.13.15.5

b. 33kV Outgoing Feeder:

One (1) out going feeder and Line PT shall also be supplied and connected on Bus Section 2 having a power evacuation capacity of 20 MW complete with all accessories similar to the present out going feeder of 20 MW capacities.

Supply, laying, termination and charging etc of cable 33/36 kV grade shall be done from this new outgoing feeder (20MW capacity) to new 33kV bay at SgTPP Switch Yard(under construction). Distance from Main Floating Solar Control Room to New 33 kV Switchyard is around 1000 mtrs. However bidder shall evaluate this distance during detail engineering.

c. Outgoing feeder for 100kVA Station Auxiliary Transformer(SAT):

One(1) Outgoing feeder for new Station Auxiliary Oil Type Transformer (100 kW capacity) shall also be supplied and connected on Bus Section 2 complete with

all accessories similar to the existing out going Station Auxiliary Transformer feeder installed at Bus section 1 of existing Common 33 kV switchgear.

Supply, laying, termination and charging etc. of cable 33/36 kV grade shall be done from this new outgoing Station Aux. Transformer Feeder to new Station Aux. Transformer are under bidder scope.

Table for new 33 kV panel extensions:

Sl No.	Description	Quantity
1	Incoming feeder from each Floating Solar Inverter Transformer (from Pond no. 1, 2 & 4) Evacuation capacity of each feeder is in line with MW capacity mentioned in the specification with 10% higher margin	3 Nos.
2.	Outgoing feeder with 20 MW capacity with Line PT	1 No.
3.	Outgoing feeder for 100 KVA SAT	1 No.
4	One Spare feeder for 3.5 MW Incoming capacity	1 No.
5.	Outgoing Transformer feeder for 2.5 MVA capacity for Storage Battery	1 No.

Details of the Electrical Layout is shown in the attached tender drawing No.SG-FLSP-DWG-E-01 for ready reference of the bidder.

5.9.6.2 STANDARDS

The equipments covered under this chapter shall comply with the requirement of latest edition of following IS/BS/IEC specifications as amended up to date except where specified otherwise.

Sl. No.	Standards	Description
1	IS: 5	Colors for ready mixed paints & enamels
2	IEC-62271-100,200; IEC-600298 / 600694; IS-3427	AC metal enclosed switchgear & control gear for rated voltages above 1 kV & up to & including 52 kV.
3	IS: 13947/ IEC 60529	Degree of protection provided by enclosures for switchgear.
4	IS: 1901	Specification for visual indication lamps
5	IEC-60056 / IS 13118 /IEC	High Voltage Alternating current Circuit Breakers
6	IS: 2705 - (Part I - IV)/ IEC 60185	Current Transformers

Sl. No.	Standards	Description
7	IS: 3156 - (Part I - IV)/ IEC 60186	Voltage Transformers
8	IEC: 60694	Common clauses for high voltage switchgear & control gear
9	IS: 1248	Indicating Electrical measuring instruments
10	IS: 8084	Inter connecting Bus bars for AC voltage between above 1 kV up to and including 36 kV
11	IS-3231 & 3842 / IEC 60255	Electrical relays for Power Systems
12	IEC: 62271-102/ IEC 60129	Alternating current disconnectors and earthing switches
13	IEC-99-4	Metal oxide surge arresters without gates for A.C. systems

Equipment meeting with other authoritative standards which ensure an equal or better quality is also acceptable. Where the equipment conforms to any other authoritative standard, the salient points of difference between the standard adopted and IS/IEC shall be clearly brought out in the tender. Complete set of documents and standards in English shall be supplied by the contractor without any extra charge. It shall, however, be ensured that equipment offered comply with one consistent set of standards except in so far as they are modified by the requirement of this specification.

5.9.6.3 SPECIFIC TECHNICAL REQUIREMENTS/PARAMETERS:

All indoor switchgear panels shall have minimum technical parameters for design consideration as mentioned hereunder:

BUS BARS/CUBICLE

SI. No.	Description	Requirement
1	Nominal/Highest System Voltage	33 kV/36 kV
2	Type of Installation	Indoor
3	Max. Ambient Temp. and Temp. Rise	As per IS/IEC
4	Min. Clearances in air (Phase to Phase and Phase to Earth)	As per IS/IEC
5	Degree of protection	IP 52
6	Continuous current rating	As per system design which is capable of handling 20MW power
7	Short Time Current Rating for 1 sec	25 kA
8	Rated Power Frequency withstand voltage	70 kV (rms)
9	Rated Lightning Impulse Withstand Voltage	170 kV (peak)

SI. No.	Description	Requirement
10	Cable Entry	From bottom

CIRCUIT BREAKERS:

SI. No.	Description	Requirement
1	Type	Vaccum
2	No. of Poles	3
3	Nominal/Highest System Voltage	33 kV/36 kV
4	Type of Installation	Indoor
5	Duty Cycle	O- 0.3 sec-CO-3 min-CO
6	Operating cycles	Min. 10000
7	Control Voltage	110/220 V DC (10% to -15%)
8	Short Time Current Rating for 3 sec	25 kA
9	Continuous current rating	As per system design
10	Symmetrical Breaking Current Capacity	25 kA (rms)
11	Short Circuit Making Current	62.5 kA
12	Degree of protection	IP 55
13	Operating mechanism	Spring Charged

CURRENT TRANSFORMER

SI. No.	Description	Requirement
1	Type	Cast Resin Type
2	Nominal/Highest System Voltage	33 kV/36 kV
3	Short Time Current Rating for 1 sec	25 kA
4	No. of Phases	Single
5	Insulation Class	Class B or better
6	Rated Power Frequency withstand voltage (Primary/secondary)	70 kV (rms)/3 kV (rms)
7	Rated Lightning Impulse Withstand Voltage	170 kV (peak)
8	Protection Class	5P20
9	Diff./REF Protection Class	PS
10	Metering Class	Class 0.2 and ISF <=5

POTENTIAL TRANSFORMER

SI. No.	Description	Requirement
1	Type	Cast Resin Type

SI. No.	Description	Requirement
2	Nominal/Highest System Voltage	33 kV/36 kV
3	Short Time Current Rating for 1 sec	25 kA
4	No. of Phases	Single
5	Insulation Class	Class B or better
6	Rated Power Frequency withstand voltage (Primary/secondary)	70 kV (rms)/3 kV (rms)
7	Rated Lightning Impulse Withstand Voltage	170 kV (peak)
8	Accuracy Class	0.2 for metering and of 0.5 for other purposes.

ISOLATOR/DISCONNECTING SWITCH

SI. No.	Description	Requirement
1	Type	Cast Resin Type
2	Nominal/Highest System Voltage	33 kV/36 kV
3	Short Time Current Rating for 1 sec	25 kA
4	No. of Poles	3
5	Continuous current rating	As per system design which is capable of handling 20MW power
6	Short Time Current Rating for 3 sec	25 kA
7	Rated Power Frequency withstand voltage	
	a. To earth & between poles	70 kV (rms)
	b. Across isolating distance	80 kV (rms)
8	Rated Lightning Impulse Withstand Voltage	
	a. To earth & between poles	170 kV (peak)
	b. Across isolating distance	195 kV (peak)

SURGE ARRESTOR

SI. No.	Description	Requirement
1	Type	Metal Oxide Gapless
2	Rated Voltage	30 kV
3	Nominal Discharge Current	As per IS
4	Installation	Indoor
5	Rated Power Frequency withstand voltage	70 kV (rms)
6	Rated Lightning Impulse Withstand Voltage	170 kV (peak)

EXISTING 33 KV SWITCHGEAR FOR COMMON POWER EVACUATION:

SI. No.	Description	Requirement
1	Type	Vaccum, VM-36
2	No. of Poles	3
3	Make	BHEL, Bhopal
4	Nominal/Highest System Voltage	33 kV/36 kV
5	Nominal current	1250A
6	Type of Installation	Indoor
7	Duty Cycle	O- 0.3 sec-CO-3 min-CO
8	Control Voltage	220 V DC
9	Short Time Current Rating for 3 sec	25 kA
10	Short Circuit Making Current	62.5 kA

5.9.6.4 GENERAL REQUIREMENTS

The 33 kV Indoor Switchgear shall be designed considering the minimum general requirements as mentioned hereunder:

A. STRUCTURAL & MECHANICAL CONSTRUCTION

- i. The Switchgear shall be factory assembled, totally enclosed, metal clad, dead front cubicle. It shall be of sheet Steel (preferably galvanized to avoid rusting) construction and shall be dust, moisture and vermin proof complying with degree of protection of not less than IP-4x as per IS-3427 (1997). The panels shall be of Metal Clad compartmentalized design with all the High Voltage compartments viz. Circuit Breaker, Bus Bar, Current Transformers and Voltage Transformers separated by metallic partitions. The switchgear panels shall be rigid without using any external bracing. The switchboard panels should comply with relevant ISS/IEC and revision thereof and shall be designed for easy operation maintenance and further extension. Bus bar, metering, circuit breaker chamber, cables and cable box chamber should have proper access for maintenance, proper interlocks should be provided. All instruments shall be non draw-out type and safeguard in every respect from damages. The switchgear shall be complete with all necessary wiring fuses, auxiliary contacts, terminal boards etc.
- ii. The overall design of the switchboard shall be such that front access only is required. The panels shall be constructed from prime quality folded and bolted steel sheet of 2 mm thick or Al-Zn sheet steel. Only doors and end covers shall be painted with paint shade as specified.

The observation window on the CB compartment door shall be provided. Observation window shall be of same material and construction as the type tested design/construction.

The design of the panels shall be such that no permanent or harmful distortion occurs either when being lifted by eyebolts or when moved into position by rollers or transpallets.

The switchgear and control gear should have the minimum degree of protection (in accordance with IEC 60529)

- IP 4X for the enclosure for rated current up to 1250A
- IP 3X for the enclosure for rated current up to 2500A
- IP 2X for the partition between compartments

The switchgear must be readily extendable in either direction.

- iii. For Seismic Applications: The switchboard may be subject to seismic disturbance, hence the switchgear supplier shall provide proof by type test or calculation according to IEEE 693 standards, documentation to support the offered equipment.
- iv. Each cubicle shall be equipped with anti-condensation heater controlled by thermostat.
- v. Assembly of all current carrying parts shall be such that they shall be easily accessible for inspection and maintenance.
- vi. Switchgear cubicles shall be satisfied the requirement of IEC:62271-200, IEC:60298, IEC:60694.
- vii. Switch gear shall be supplied with basic operating tools.
- viii. The switchgear and control gear shall be suitable for continuous operation under the basic service conditions indicated below.

Ambient temperature °C	- 5 to + 50
Relative humidity	up to 95%
Altitude of installation	up to 1000m, IEC120.

B. BUS BARS AND CONNECTORS

Bus bars and all other electrical connections between various components shall be made of Electrolytic copper of adequate cross-section. The bus bar section shall be of ample capacity to carry the rated current for 20MW power with 10% higher margin, continuously without excessive heating and for adequately meeting the thermal and dynamic stresses in the case of short circuit in the system up to full fault MVA.

All bus bars shall be rigidly and firmly mounted. Spacious bus bar chamber shall be provided with use of tubular busbar design and free from any high voltage stresses by avoiding all sharp edges and bringing them to uniform potential. Bus bar shall be sleeved for full voltage. Sleeve shall be heat shrinkable BTPM type of Raychem make. **No PVC sleeve in bus bar for 36KV is acceptable.**

Bus bar shall be located in a separate metal clad chamber and shall be air insulated. It shall be adequately supported on insulators or integral epoxy spouts to withstand dynamic stress due to the short circuit current as specified.

Bus bar shall be extensible on either side to make it in switch board configuration in future.

C. CIRCUIT BREAKER

- a) The Circuit Breaker shall be drawing out type suitable for installation in the switchgear cubicle. The breakers shall comply with IS-13118 / IEC-60056 conforms to latest amendment thereof.
- b) The Circuit Breaker shall be spring operated, DC Motor charged, manually released spring closing mechanism with three pole simultaneous operation. The indicating device shall show the OPEN and CLOSE position of breaker visible from front of the cubicle. The spring charging time of the motor shall not exceed 15 sec. The "TRIP" and "CLOSE" coils shall be of reliable design and low consumption preferably less than 300W. It shall be possible to manually charge the circuit breaker operating spring in case of auxiliary supply failure.
- c) The breakers shall be capable of Making & Breaking the short time current in accordance with the requirement of ISS 13118 / IEC 60056 conform to latest amendment thereof and shall have 3 phase rupturing capacity of 31.5KA at 33KV. The continuous current rating of breaker shall not be less than 1250A for all items.

- d) The circuit breaker shall be isolated by horizontal racking and positively fixing the unit into any one of the following positions;
- **Service position;** main and auxiliary circuits connected
 - **Test position;** main circuits disconnected auxiliary circuits connected. Circuit breaker in its isolated position shall be completely contained in the apparatus compartment with shutters on main circuit closed and compartment front door closed.
 - **Withdrawn position;** main circuits and auxiliary circuits disconnected. Circuit breaker is removed out of the cubicle.
- e) Locking of circuit breaker in the test position shall be possible by means of key lock on the earth switch manoeuvre.
- f) A position indicator switch or viewing window must be provided for visual indication of the circuit breaker position.
- g) Comprehensive interlocking system to prevent any dangerous or inadvertent operation shall be provided. Isolation of circuit breaker from bus bar or insertion into bus bar shall only be possible when the breaker is in the "OPEN" position.
- h) Each circuit breaker shall be provided with following accessories.
- i) ON-OFF indicator for indicating circuit breaker position.
 - ii) Trip push button
 - iii) Shunt trip coil operating between 70% - 110% of rated control voltage.
 - iv) Close coil, operating between 85% - 110% of rated control voltage.
 - v) Spring charge motor, operating between 90% - 110% of rated control voltage.
 - vi) Two trip coils and one closing coils shall be provided in all the breakers.
 - vii) Metering with higher class of accuracy (Class 0.2 and ISF ≤ 5 for metering.)
- i) The switchgear shall be provided with facilities for full operation from a remote point. In case of Local Operation of circuit breakers, Control switch of Circuit Breaker shall be located at such a height so that a man can operate standing on ground/floor. It shall be possible to trip the circuit breaker locally by mechanical means.

- j) The circuit breaker truck shall ensure earth in both connected and disconnected positions.
- k) An electro-mechanical device shall be provided to ensure the auxiliary circuits have been securely connected between the fixed and moving portions of the switchgear, before allowing closing operation of the circuit breaker. The voltage rating of the device shall be the same as the voltage used for the closing circuit.
- l) Tripping and/or release coils shall be continuous rated to ensure longer life but rating should not exceed 300 W each. The electrical tripping device shall be of a type which acts directly on the circuit breaker mechanism and shall give positive operation for a supply voltage of 70% of nominal at DC control voltage.
- m) Circuit breakers will be provided with at least one spare normally-open and one spare normally-closed contact, each wired out to terminals for the connection of external wiring.
- n) Each circuit breaker shall be interlocked to prevent:
 - the breaker being inserted into service position unless it is open
 - the breaker being withdrawn from the service position unless it is open
 - the breaker being closed unless it is fully in the service or test position
 - remote operation whilst in the service position and/test position
- o) Circuit breakers shall be mechanical latching and electrical and mechanical tripping. The operating mechanism shall be trip-free and shall include an anti-pumping device.
- p) Shutters: Circuit breaker compartment should have non magnetic non ferrous automatic safety shutters, which shall be opened and closed by the mechanical drive of the circuit breaker. The bus bar and circuit spout covers shall be operated independently of each other. Padlock facilities can be provided on the metal shutters.
- q) INTERLOCKING Isolation and connection of the circuit breaker shall be carried out inside the compartment with the door closed. The following mechanical interlocks shall be provided for service safety:
 - Interlocking which prevents racking-in and racking-out of the circuit breaker when closed

- interlocking which prevents manual or electrical closing of the circuit breaker in the intermediate positions between connected or isolated.

D. CURRENT TRANSFORMER :

The CT shall be mounted in a manner to make it very easy for fitting / replacement at site. It shall be designed with built in adjustable cable holding clamps, makes it very easy for removal/sturdy fitting of power cables and to prevent any swing due to forces encountered during short circuit. P1 of primary side of the in-built CT shall be at bus side of all the panels.

E. POTENTIAL TRANSFORMER

Three numbers Single phase draw out type PT of ratio $33000/\sqrt{3}$; $110/\sqrt{3}$ Volts with HT/LT fuses mounted on an independent trolley housed at the bottom in the same feeder/transformer panel or separately vertical housed . This Line PT shall not get disconnected along with the Circuit Breaker in case the breaker is drawn out from 'SERVICE' position. Arrangement shall be made in such a way so that PT primary fuse can be replaced without switching OFF the breaker.

F. AUXILIARY/CONTROL WIRING

All the secondary wiring in the panel shall have high quality PVC insulation 1100 volts grade and the same shall be of standard Copper Conductor of size not less than 2.5 sq. mm. for control circuit and 4 sq. mm. for CT circuits. Colours of the secondary / auxiliary wiring should conform to ISS 375/1963 conform to latest amendments thereof. All wiring shall be neatly run and group of wiring shall be securely fixed with clips so that wiring can be checked without necessity of removing the clamps. Ferrules with number shall be provided on both end of the wiring.

G. PAINTING The Panels shall be pre-treated using 7-Tank process and then Epoxy Powder Coated with Paint shade of RAL 7032.

H. EARTHING

- a. An earth bus of size minimum 40 mm x 6 mm or equivalent copper shall be provided and shall be extended throughout the length of the switch board with a provision to extend further on both sides of the end switchboard for future extension of switchboards.
- b. It shall be possible to connect each circuit of the switchgear to earth, through earthing switches suitable for fault make current.

- c. Earthing switch shall be mechanically interlocked with the associated breaker as per interlock requirement.
- d. Earthing circuit shall be suitable for testing at 31.5KA for 1.0 sec.
- e. Breaker compartment shall have scrapping earth bar and spring load finger shall be provided in withdrawal truck.
- f. Provision of Busbar earthing at both side of Bus-Coupler is to be provided.

I. TYPE TESTS

The bidder shall submit following Type test reports (not more than five year old from the date of bid opening) along with the bid to prove the capability and suitability of his offered switchgear.

- i. Short Time Current Test for 31.5KA for 3 second.
- ii. Short Circuit Test duties on Circuit Breaker.
- iii. Impulse withstands Test.
- iv. Power Frequency withstands Test.

If bidder fails to provide test report they have to do the type test without any price implication before delivery of equipment.

5.9.6.5 OTHER SOME GENERAL REQUIREMENTS:

- The switchgear shall be indoor, free standing, sheet metal clad, draw out type and shall be fully compartmentalized.
- The Switchgear enclosures shall be totally enclosed design, dust tight and vermin proof.
- Each panel shall be equipped with space heaters to prevent moisture condensation within the enclosure and shall be complete with MCB, thermostats and auxiliary relay (if required).
- Switchgear design shall comprise of fully compartmentalized execution having separate vertical sections for each circuit.
- Structure, buses and control wiring shall be designed and arranged in such a manner so that future extension of the switchboard would readily be feasible.
- All corresponding components of the circuit-breakers and switchgear of same rating shall be fully interchangeable.
- The power shall be fed from new 33 kV Transformer Yards placed adjacent to respective Inverter cum Control room through 33 kV XLPE Cable. This cable shall be connected at new extension 33 kV panel at Main Control Room near Raw Water Pond 3. Cable shall be laid **through buried / concrete trench / cable trestle**

subject to approval during detail engineering. For buried cable minimum depth of one (1) meter with cable marker, distance between two cable markers shall not be more than 30m.

- The disconnecting switches shall be provided with local electrical/manual control. The disconnecting switches shall be fitted with earthing link wherever required. The disconnecting switch shall be connected between the transformer and circuit breaker for the power incoming from solar PV and for synchronization between the bus bar and transmission line through breaker, at 33 kV. Details layout shown in the tender drawings.
- The supplier shall ensure that the current transformers shall have adequate VA output for the type of protection & metering offered. The supplier shall also ensure that the current transformers quoted by him have adequate output for prescribed accuracy class and accuracy limit factor for the type of relays and instruments connected in their circuits. PS class CTs shall have low secondary resistance and high knee point voltage so as to avoid any possibility of CT saturation under through fault conditions.
- Three single phase voltage transformers shall be suitable for connecting in a bank of three phase voltage transformers for protection and measurement purpose for each incomer and outgoing feeders. Separate and dedicated voltage transformers shall be provided for synchronization.
- The lightning arrester & voltage transformer (LAVT) cubicles for 33 kV shall comprise of lightning arresters and capacitors (for surge protection) and voltage transformers. The LAVT & VT cubicles shall be dust tight, vermin-proof.
- Each cubicle shall be equipped with space heaters, thermostats, illumination lamps & 240 V AC, 5A receptacle.
- Suitable single compression type, heavy duty brass cable glands with check nuts, rubber sealing ring and brass washers mounted on a removable gland plate shall be supplied with the switchgear to support all power and control cables entering the switchgear.
- Cables for each equipment must be tagged with permanent metal tag of impregnated cable number as per drawings at MCC/switchgear end and equipment terminal end as well as in the mid portion of the cables at certain distances as instructed by the owner or his authorized representative.
- The relay for the switchgear units shall have all the features as specified under Cl. no. 5.13.11 of, Sec-V of the Technical Specification.
- The switchgear units shall have the remotely controlled.

- The accuracy class of indicating instruments shall be 1 or better as per IS. The accuracy class of meters for commercial metering shall be 0.2. All instruments shall have means for calibration, testing and adjustment at site.
- Three phase watt hour meters conforming to latest issue of relevant Indian standard shall be provided with test link for CTs & PTs. Meters shall be compensated for temperature errors and factory calibrated to directly read the primary quantities.
- Following equipments at 33 kV switchgear shall be monitored and control from OWS of existing SCADA/DCS:
 - 1) Circuit breaker - On/Off status & Control, Test, service, spring charged, Trip Circuit unhealthy, Lock out operated etc.
 - 2) Transformer - Winding temperature & Oil temperature, Buchholz etc Alarm status
Through hardwire. IPR shall be placed at switchgear end.
 - 3) Energy meters through RS 485 network.
 - 4) Numerical Relays through RS 485 network.
 - 5) Voltmeters- from transducer as analogue signal.
 - 6) Ammeters- from transducer as analogue signal.
- The switchgear shall be capable of addition another two outgoing and two incoming feeder and separate line PT provision for future extension. Necessary space provision should be envisaged during control room design.

5.9.6.6 APPROVAL

The Detailed Design Report submitted by the contractor to WBPDCCL must contain but not limited to the following details of the Ring Main Unit/Switchgear:

- Detailed specification of all the items.
- Necessary Drawings
- All necessary test certificates and approvals etc.

The successful bidder required to produce all necessary test certificates and approvals of the product as per relevant standard with the Detailed Design Report.

Prior to the delivery of the product, the contractor shall submit but not limited to the following documents:

- Guarantees
- Instructions for installation and operation, manual

- Electrical diagrams
- Safety precautions
- Detailed schematics of all power instrumentation and control equipment and subsystems along with their interconnection diagrams. Schematics shall indicate wiring diagrams, their numbers and quantities, type and ratings of all components and subsystems etc.

The contractor can deliver the product to the site only after receiving such approval against their prayer in writing from WBPDCCL.

5.9.7 33kV OUTDOOR SWITCHYARD:

5.9.7.1 SCOPE:

This specification covers the design, manufacture, testing at manufacturer's works before dispatch, supply, delivery at site, transit insurance, storage at site, erection, testing & commissioning of following outdoor equipment at switchyard for Power Evacuation from three inverter control room building to existing floating Solar Control room building(**Refer NIT SLD**).

The following equipments to be envisaged for power evacuation of the solar plant.

- i. Isolator-** Isolator with earth switch for power evacuation from Inverter Transformer to 33 kV Existing Switchgear.

The rating of the Isolator switch shall match with the corresponding breaker ratings. It shall be of centre rotating type with AC motor operated mechanism and manually operated earth switch. Each Isolator shall be installed near each Inverter transformer after LA.

- ii. Lighting arrester- (as per SLD)**

Gapless type of lighting arrester (Zno) with counter shall be used for 33kV system. LA should be heavy duty station class type. LA shall be placed over Four Pole structure. Bidder shall provide necessary earthing in line with specification to meet IS requirement.

- iii. 4 Pole structure:**

- i) Inverter Transformer Yard : each transformer yard.
- ii) 20 MW Evacuation point at Switchyard : 2 nos.

- iv. 33/36 kV Grade cable:**

- b) Complete supply, laying, termination charging etc. of 33/36 kV grade Cable from new 33 kV Extension panel at existing 33 kV Indoor Switchgear at Floating Solar Control Room to Isolators on Four Pole structure before all the Inverter Transformers.
- c) Complete supply, laying, termination charging etc. of 20 MW, 33/36 kV grade Cable from new 33 kV Extension panel at existing 33 kV Indoor Switchgear at Floating Solar Control Room to new 33 kV Outdoor switchyard Bay.
- d) Complete supply, laying, termination charging etc from extension panel of 33kV existing Indoor switchgear at Floating Solar Control Room to one number new Station Auxiliary Transformer.
- e) Bidder shall submit cable sizing calculation during detail engineering for approval.

V. Inverter cum Control Room and CR Panel:

Control Relay Panel with 220 V DC System for Control, indication and protection and testing, metering shall be considered for each 33 kV VCB and its associated Isolator.

VI. OUTDOOR 36 kV VCB

33 kV Outdoor VCB shall be installed for evacuation of Power from each Pond Plant Inverter transformer to Main Control Room near Raw Water Pond 3 and necessary control and protection panel shall be provided in the Inverter cum control room. Details specification of 36 kV VCB is as furnish in clause no.5.9.30.

5.9.7.2 OTHER REQUIREMENTS:

- i. All switchyard structure should be lattice mild steel structure hot dip galvanized.
- ii. All the buses should be adequately sized for fault and continuous current requirement.
- iii. For 33kv bus, suitably supported single “Moose” conductor will be used in each phase.
- iv. The bus bar fittings, connectors etc will be of suitable aluminium alloy having desired mechanical strength and electrical properties.

- v. The contractor shall be fully responsible for carrying out all co ordination and liaison work with electrical inspectors and other statutory bodies for implementation of the work, as and when required.
- vi. The relay for the switchgear units shall have all the features as specified under **Cl. no. 5.13.11** of, Sec-V of the Technical Specification.
- vii. The scopes which are mentioned above are only for indicative purpose only. The contractor to supply all equipments which are also required for successful completion of the work.

5.9.7.3 Approval

Before starting manufacturing any equipment, the contractor shall have to take approval of relevant drawings and data from the purchaser.

5.9.8 STATION AUXILIARY TRANSFORMER

5.9.8.1 SCOPE

This section covers the activities related to design, manufacturing, testing at works, supply, insurance, transportation and delivery at Project site, storage, erection, testing, commissioning of 33 / 0.415 kV dry type one number station auxiliary transformers and associated equipments as detailed hereunder.

The scope of supply shall also include necessary spares required for normal operation & maintenance of transformers for a period of 5 (five) years & special tools & plants required for erection & maintenance. Corresponding parts of all the equipments & spares shall be of the same material & dimensions, workmanship & finish and shall be interchangeable. All the material & workmanship shall be of suitable commercial quality as have proven successful in their respective uses in similar services & under similar condition.

The transformers and associated equipment shall be suitable for interfacing with SCADA system and all necessary transducers shall be included in the scope of supply.

5.9.8.2 STANDARDS

The equipments and materials covered by this specification shall conform to the latest edition of following Indian Standards or equivalent IEC standards except where specified otherwise in this specification:

Sl. No.	Standards	Description
1	IS: 2026 (Part I to IV) /IEC 76	Power Transformer

Sl. No.	Standards	Description
2	IS: 2099/IEC 137	Transformers bushings
3	IS: 2705/IEC 185	Current transformers
4	IS: 1180	Three phase distribution transformer
5	IS: 6088	Dimensions for porcelain transformer bushings
6	IS: 3347	Loading guide for oil-immersed transformers
7	IS: 335	Transformer oil
8	CBIP No. 295	CBIP Manual on Transformers Publication

Equipment meeting with other authoritative standards which ensure an equal or better quality is also acceptable. Where the equipment conforms to any other authoritative standard, the salient points of difference between the standard adopted and IS/IEC shall be clearly brought out in the tender. Complete set of documents and standards in English shall be supplied by the bidder without any extra charge. It shall, however, be ensured that equipment offered comply with one consistent set of standards except in so far as they are modified by the requirement of this specification.

5.9.8.3 TECHNICAL REQUIREMENTS

- Capacity of the Station Auxiliary Transformer (SAT) shall be 100 kVA. It shall be similar to the existing SAT. Bidder shall provide Baffle walls to meet the Statutory and TAC requirement.
- HT side of the transformer shall be connected to the 33 kV Bus through an indoor VCB and LT side shall be terminated to the Station Service Board (SSB)/ 415 V LT Switchgear.
- SAT shall be installed at the space provided in the Transformer Yard adjacent to the existing Common Floating Solar Control Room near Raw Water Pond #3.
- The transformer shall be able to perform satisfactorily under voltage variation limit of +/- 10 % and frequency variation limit of +/- 5 %.
- Vector group of the transformer shall be Dyn11
- Off Circuit Tap changer (-10% to +10% @1.25% steps) shall be provided with the transformer. Owner will take final decision regarding this based on the proposal submitted by the contractor.

- % Impedance, type of bushing, class of insulation, temperature rise etc. shall be as per relevant Indian Standard.
- The transformers shall be suitable for co-ordination and integration with existing SCADA System and necessary contacts and/or ports for the purpose shall be provided.
- Earthing arrangement of the transformers shall be provided as per the relevant Indian Standard.
- Necessary protection arrangement like should be provided in the transformer.
- Construction of different parts of the transformer shall conform to the latest edition of relevant Indian Standard.
- Fittings and accessories shall be provided as per relevant Indian Standard code.
- Transformer oil shall conform to latest edition of IS 335.
- 415V side of the transformer shall be terminated through cable with the new extended section of the LT Switchgear.

5.9.8.4 APPROVAL

The Detailed Design Report Submitted by the contractor to WBPDC must contain but not limited to the following details of the transformers:

- Detailed specification
- Fittings and Accessories
- Necessary Drawings shall contain but not limited to the following:
 - Outline dimension drawings of transformers and fittings/accessories
 - Assembly drawings and weight of main components.
 - Transport drawings, showing main dimensions and weight of each package.
 - Foundation details
 - Tap-changing equipment
 - Name-plate diagrams
 - Schematic control and wiring diagrams for all aux. equipment etc.
- Tools and spare parts etc.
- Type Test Reports and certificates etc.

A joint inspection and testing will be done by owner and the authorized representatives of the contractor at the manufacturer's workshop, if desired so by the owner. Testing will be done as per relevant IS Code.

Prior to the delivery of the product, the contractor shall submit but not limited to the following documents:

- Guarantees
- Instructions for installation and operation, manual
- Test Reports for routine and acceptance tests etc.

The contractor can deliver the product to the site only after receiving such approval against their prayer in writing from WBPDCCL.

5.9.9 LT SWITCHGEAR

5.9.9.1 SCOPE

The scope of work under this specification covers the design, manufacture, assembly, testing at manufacturer's works, transportation, transit insurance, delivery at site, storage, installation, testing, and commissioning of indoor type following 415V LT Switchgear complete with all accessories and spares.

- Extension of existing LT switchgear at Main Floating Solar control room is under Bidder's scope. This switchgear extension shall have one Incomer and One Bus-coupler along with out-going feeders for new Floating Solar Plant under this package.
- Solar Plant of each Raw Water Pond under this package shall have two dedicated power feeders (MCCB) of equal capacity in this LT Switchgear from both of the Bus-section.
- One Sub-ACDB shall be installed with two incomer (MCCB's) and one Bus-coupler MCCB at each of the Inverter cum Control room for local illumination and auxiliary loads for each Solar Plant. These ACDB's shall receive power from the extended LT Board as mentioned elsewhere through 1.1 kV grade 3Ph, 4W cable.
- Supply, laying, termination of these cables for charging of these new ACDB is under this package.

The Scope shall include supply of 415 V (3 phase, 1 neutral and single phase for lighting etc.) transmission line (all Al conductor) for the entire area from the LT switchgear at both site with necessary breaker, switch fuse unit as and when required, Boards as above along with gland plates for all power and control cables, base frames, special tools i.e. operating handles, trolley necessary for removing the circuit breakers for maintenance etc. Isolators should be provided in the line to connect or isolate the connection from both the station auxiliary transformer.

The scope shall include all associated devices, components, relays, contactors, switches etc. required for satisfactory operation of the switch boards as per the proposed logic control scheme. The scope of supply shall also include necessary spares required for operation & maintenance of switchgear equipments for a period of 5 (five) years & special tools & plants required for erection & maintenance.

Corresponding parts of all the equipments & spares shall be of the same material & dimensions, workmanship & finish and shall be interchangeable. All the material & workmanship shall be of suitable commercial quality as have proven successful in their respective uses in similar services & under similar condition.

The existing Floating Solar LT switchgear near Floating Solar Control Room has already designed in such way that it should capable to accommodate auxiliary load of these solar power plants. Necessary equivalent space provision also kept physically for present extension of bus on both side of the switchgear.

Table for new 415 kV panel extensions and Sub-ACDB:

Sl	Description	Quantity
1.	Incoming feeder (ACB) from each 100 KVA Aux. Service Transformer Capacity of each feeder is in line with KVA capacity mentioned in the specification with 10% higher margin;	1 Nos.
2.	One Bus-coupler breaker (ACB)	1 No.
3.	Outgoing feeders for each Sub ACDB from both Bus sections LT switchgear at Main control Room.	According to number of Sub-ACDB
4.	Sub-ACDB for each Inverter-cum Control room.	1 No.
5.	Spare feeder	2 nos. of each type and rating for each DB.

- **One ACDB inside New Battery Charger Room at 10 MW Ground Solar Plant:**

Table with description

Sl	Description	Quantity

1.	Incoming feeder (100 A MCCB) from WBPDC existing source from 500 mtrs distance. Supply, laying, termination of cable and charging of this panel is under bidders' scope	1 Nos.
2.	Outgoing feeder 32 A MCCB	4 nos.
3.	Outgoing feeder 16 A MCCB	6 nos.

5.9.9.2 STANDARDS

The equipments covered under this chapter shall comply with the requirement of latest edition of following IS/BS/IEC specifications as amended up to date except where specified otherwise.

Sl. No.	Standards	Description
1	IS: 13947 (Part 1 to 5)	Specification for Low-Voltage Switchgear and Control gear.
2	IS: 10118 (Part 1 to 4)	Code of practice for selection, installation and maintenance of switchgear & control gear.
3	IS: 1248	Specifications for Electrical Indicating Instruments
4	IS: 2633	Hot dip Galvanizing
5	IS: 2705	Current Transformers
6	IS: 3156	Voltage Transformers
7	IS: 3231	Electrical Relays for Power System Protection
8	IS: 5082	Wrought Aluminium and Aluminium Alloy bars, tubes and sections for electrical purposes.
9	IS: 8623	General requirement for factory built assemblies up to 1000V.
10	IS: 8828	Circuit breakers for over current protection for household and similar installations
11	IS: 13703	Low Voltage fuses for voltages not exceeding 1000V AC
12	IS: 11353	Guide for uniform system of marking and identification of conductors and apparatus terminals.

Equipment meeting any other authoritative national or international standards that ensure equal or better quality than the standards mentioned above are also acceptable. Where the equipment conforms to any other standards than those mentioned above, salient points of difference between the standards adopted and standards mentioned above shall be brought out in the tender.

The electrical installation shall meet the requirement of Indian Electricity rules and other statutory regulations as amended up to date and relevant BIS code of practice.

5.9.9.3 TECHNICAL REQUIREMENTS

- Main Incoming A.C. circuits on Station service Board shall be controlled through microprocessor based numerical relay with draw out type Air Circuit Breaker. Type and capacity of the breakers shall be proposed by the bidders in their bid considering the total auxiliary load of the plant.
- The LT switchgears shall be suitable for indoor installation in the control room.
- LT switchgears shall be placed in each site control room and shall be connected to each other by means of 415 V (3 phase, neutral) transmission line along the whole area. LT switchgear at main control room shall be connected with Station Auxiliary Transformer 1 (as mentioned in the chapter “Station Auxiliary Transformer”) and LT switchgear of a local control room placed at a suitable distance away from the Main Control Room shall be connected with Station Auxiliary Transformer 1 (as mentioned in the chapter “Station Auxiliary Transformer”).
- The Station Service Board shall be sectionalized in two parts through sectionalizing breakers of equivalent capacity and protection of incomers on the bus to ensure continuity of supply to the auxiliaries in case of failure/fault on one section.
- For interconnection with various boards and all outgoing feeder circuits, 50 kA, 3 pole draw-out type MCCBs with adjustable current setting shall be provided.
- The Air Circuit Breakers, Boards etc. shall have at least the following ratings:
 - No. of phases : Three
 - Rated voltage : 1.1 kV
 - Service voltage : 415 V ± 10%
 - Frequency : 50 Hz. ± 5%
 - Rated short time current rating : 50 kA for 1 sec. for bus & switchgear
 - Normal control voltage : 220V DC
 - Degree of Protection : IP 42 or higher
- The following equipments at LT switchgear shall be monitored from existing SCADA /DCS supplied by BHEL.
 - 1) Circuit breaker - On/Off status & Control, test, service, spring charged, TCS healthy, 86 operated, DC fail etc.

- 2) Auxiliary Transformer - Winding temperature Alarm status
 - 3) Energy meters
 - 4) Voltmeters-from transducer
 - 5) Ammeters-from transducer
 - 6) Numerical Relays should also be integrated with SCADA.
- The 415V switchboards shall be metal-enclosed draw out type, free standing, self-supporting, floor mounted, indoor type, totally enclosed and compartmentalized to house the switchgear. Circuit breakers and other switchgear components shall be arranged in compartments, vertically in a multi-tier formation. All metering and protection equipment associated with a particular circuit shall be housed in separate and independent compartment earmarked for particular circuit and in the fixed portion of the vertical panel in case of breaker panels.
 - Construction of all the switchboards and equipments shall conform to the latest edition of relevant IS codes.
 - All cable glands and aluminum crimping type cable lugs for all power and control cables shall be in the bidder's scope of supply. Panels shall be suitable for bottom entry of cable unless otherwise specified.
 - The bidder shall indicate clearly the de-rating factors, if any, employed for each component and furnish the basis for arriving at these de-rating factors duly considering the specified current ratings, ambient temperature etc.
 - The equipment shall comply with all safety requirements during erection and operation as per relevant standards.
 - The neutral of the incoming transformer secondary shall be connected to the neutral bus of the auxiliary boards. The neutral shall be connected to the common earthing system of the switchyard/control room.
 - All auxiliary devices for control, indication, measurement and protection such as push buttons, control and selector switches, indicating lamps, Power monitors, kWh meters and protective relays shall be mounted on the front side of the respective compartment. The design shall be such that unless required for maintenance / inspection purposes, all power ON/OFF or START / STOP and relay reset operations shall be performed without opening the panel door.
 - The switchboard panels shall be provided with thermostatically controlled space heaters to prevent moisture condensation.

- Tube light / CFL lamp fittings along with necessary isolating switches shall be provided for illumination inside the panels. Each panel shall be provided with an industrial grade power socket as well.
- The 415V bus shall be of suitable cross-section so as to be able to carry the required continuous and short circuit currents within the limits of temperature rise for the site conditions.
- Control and selector switches shall be rotary type with escutcheon plates clearly marked to show the function and positions. The switches shall be of sturdy construction suitable for mounting on panel front.
- AC Distribution Board is to be provided in the main switchgear room and in the particular local control room having auxiliary transformer as per requirements.
- Instrument transformers shall be provided and shall conform to the relevant standard.
- The relay for the switchgear units shall have all the features as specified under Cl. no. 5.13.11 of, Sec-V of the Technical Specification.
- All relays shown in the drawing and others required for operation of the system as per the specification shall be included in the scope of supply. The relays shall be of electromagnetic/ static/numerical type/ microprocessor based conforming to the requirements of IS: 8686 or IEC: 255.
- All instruments and meters shall be suitable for operation under the climatic conditions prevailing at site. The instrument cases shall be dust-proof, water tight, vermin proof, specially constructed to adequately protect the instruments against damage or deterioration due to high ambient temperature and humidity.
- The VA burden of instrument coils/elements shall be as low as possible, consistent with the best modern design.
- Watt hour meter shall be suitable for 3-Phase, 4-wire unbalanced system and shall comply generally with the requirements of relevant IS code and shall be of first grade for the purpose of accuracy classification. Watt hour meters shall be provided in each LT switchgears as well as each 33 kV switchgears.
- Panels shall be supplied completely wired internally to equipment and terminal blocks for connection to external cables entering the panel from the bottom. Terminal blocks shall be complete and provided with necessary terminal accessories for cable ends.

- Engraved PVC labels shall be provided on incoming and all outgoing breaker compartments, the exact details of legend to be engraved shall be furnished later to the contractor.
- All vertical cubicles shall be connected to earth bus bar running throughout the length of the switchboard. All doors and movable parts shall be connected to the earth-bus with flexible copper connections. Provision shall be made to connect the earthing bus bar to the main earthing grid at two ends. All non-current carrying metallic parts of the mounted equipment shall be earthed. Earthing bolts shall be provided to ground cable armours.
- Finishing work like painting etc. for switchgears should be as per relevant IS.

5.9.9.4 APPROVAL

The Detailed Design Report submitted by the contractor to WBPDCCL must contain but not limited to the following details of the LT Switchgear:

- Detailed specification of all the items.
- All necessary drawings
- All necessary test certificates and approvals etc.

Prior to the delivery of the product, the contractor shall submit but not limited to the following documents:

- Guarantees
- Instructions for installation and operation, manual
- Electrical diagrams
- Safety precautions
- Detailed schematics of all power instrumentation and control equipment and subsystems along with their interconnection diagrams. Schematics shall indicate wiring diagrams, their numbers and quantities, type and ratings of all components and subsystems etc

The contractor can deliver the product to the site only after receiving such approval against their prayer in writing from WBPDCCL.

5.9.10 DC BATTERY, BATTERY CHARGING EQUIPMENT & DCDB

5.9.10.1 SCOPE

For 220 V DC Load requirements along with DC emergency lighting, bidder shall submit battery sizing calculation for approval. Bidder to consider DC Battery Backup for 5 Hours for new Inver rooms.

The scope of work under this specification covers the design, manufacture, assembly, testing at manufacturer's works, transportation, transit insurance, delivery at site, storage, installation, testing, and commissioning of D.C equipment comprising of 220 V D.C Dual Float Cum Battery Charger with Battery Bank Plante type of suitable designed capacity complete D.C. Distribution Board and other auxiliary equipments.

a) No of Battery and Charger for 220 V DC:

Bidder should consider 2 nos. (2X100%) Dual Float cum Boost Chargers with two sets of Battery Banks and DCDB for all three nos new floating solar plant. Bidder shall distribute entire 220V DC load for all the plants from one central DCDB with dual sources (2X100%)

b) 1 No of Battery and Battery Bank for 110 V DC:

WBPDCCL is having only one no battery and one charger for 10MW Ground mounted Solar PV Plant at SgTPP. To enhance redundancy another battery and its charger with DCDB have envisaged under this package. Detail scope of 110V DC system is enumerated below:

- (i) 1 No Float cum Boost Charger with 200 AH capacity of Battery Bank (Plante type similar to existing battery of 10 MW Ground Solar) to be installed near the 10MW Ground Solar PV Plant Control Room.
- (ii) 1 no. DCDB with two Incoming and one Bus-coupler MCCB's (200 A) from FCBC and 12 nos. outgoing DC MCB/SFU. Outgoing DC MCB/SFU shall have 8 nos 16 A and 4 nos: 32A capacity. Bidder shall connect at one Incomer. Other Incomer shall be kept spare.
- (iii) For this 110 V DC Battery Set and FCBC, Bidder shall construct one small building with two separate rooms for Battery and its Charger adjacent to the existing 10 MW Ground Solar Plant Main Control Room.
- (iv) DCDB shall be installed inside Battery Charger Room. Size of the Battery room shall be not less than 3500 mm x 4000 mm with 100% redundant exhaust fan. Size of Battery Charger cum ACDB- DCDB Room shall be not less than 2500 mm x 4000 mm. Necessary cable slit, Acid proof tiles on the wall inside Battery room, Acid Proof Door, illumination with corrosion proof fixtures, tap-cell, cable connectivity with DCDB, small lighting panel etc. shall be bidders' scope.
- (v) 2 nos. of 32 A Power supply for FCBC shall be fed from new ACDB (refer LT Switchgear specification).

The scope shall include all associated devices, components, relays, contactors, switches etc. required for satisfactory operation of the DC equipment as per the proposed logic control scheme.

The scope of supply shall also include necessary spares required for normal operation & maintenance of DC equipments for a period of 5 (five) years and special tools & plants required for erection & maintenance.

Corresponding parts of all the equipments & spares shall be of the same material & dimensions, workmanship & finish and shall be interchangeable. All the material & workmanship shall be of suitable commercial quality as have proven successful in their respective uses in similar services & under similar condition.

5.9.10.2 STANDARDS

The equipments covered under this chapter shall comply with the requirement of latest edition of following IS/BS/IEC specifications as amended up to date except where specified otherwise.

Sl. No.	Standards	Description
1	IS: 1651	Stationary cells & batteries, lead acid type (with tubular positive plates)
2	IS: 266	Battery grade Sulphuric Acid. (Battery electrolyte)
3	IS: 1069	Water for storage batteries
4	IS: 1146	Rubber & Plastic containers for lead Acid storage batteries
5	IS: 1248	Electrical Indicating Instruments
6	IS: 13947	Low voltage switchgear and control gear
7	IS: 3895	Mono-crystalline semi-conductor rectifier cells & stacks
8	IS: 8320	General requirement and methods of tests for lead acid storage batteries
9	IS : 6071	Synthetic separators for lead acid batteries
10	IS : 8623	Factory built assemblies of switchyard and control gear for voltage up to including 1000 V AC and 1200 V DC (Part 1 to 3)
11	IS : 4540	Non-crystalline semi-conductor rectifier assemblies & equipment

Equipment meeting any other authoritative national or international standards that ensure equal or better quality than the standards mentioned above are also acceptable. Where the equipment conforms to any other standards than those

mentioned above, salient points of difference between the standards adopted and standards mentioned above shall be brought out in the tender.

5.9.10.3 GENERAL REQUIREMENTS

Minimum general requirements for the DC Battery, Battery charger and DC Distribution Board are mentioned below.

- Lead acid tubular type battery of required rating shall be provided at Main Control Room and each Local Control room. Battery Bank at Main Control Room shall be 220 V and Battery Bank at Local Control Rooms shall be selected based on the Control Voltage required for closing and tripping of 33 kV Indoor type VCBs. 10 hours continuous discharge shall be considered for sizing the battery.
- One float charger and one float cum boost chargers shall be provided to maintain constant voltage at D.C. bus bars while supplying the continuous load in addition to keeping the battery on float charge.
- In case of sudden D.C. requirements due to failure of A.C. supply or charger itself, the battery shall be capable of meeting the system load demand. In case of failure of float charger supplying the continuous DC load, the affected battery charger shall get disconnected automatically from the DCDB and the complete D.C. load requirements shall be met by the float charger of float cum boost charger unit.
- The charger shall be protected against overloads by having suitable characteristics so that all loads in excess of the capacity of the charger would be transferred to the battery.
- In the event of failure of A.C. supply, the battery shall meet the complete D.C. requirements. After the discharge of battery to a considerable extent, the boost charger on restoration of A.C. supply shall recharge the battery in a short period. During the period of boost charging, the D.C. load requirements of power station shall also continue to be met.
- The distribution board with necessary switch and interlock, if any, shall be provided for distributing the D.C. power for the control & protection circuits, emergency D.C. supply for essential lighting etc.
- The bidder may give his recommendation on the scheme of operation of battery, battery chargers as described in the specifications. However, the decision of the owner in this regard shall be final and bound to the bidder/contractor.

- The battery shall be capable of delivering the rated output at the minimum temperature of -3°C and maximum temperature of +40°C.
- The battery shall be mounted on the two tier wooden racks supplied along with the battery. Each cell as well as its locations shall be numbered for proper record of maintenance operations. Battery should be placed on the porcelain base kept on the wooden rack.
- The battery shall be connected to D.C. distribution board by single core cables laid above ground. Suitable terminal arrangement with glands shall be provided for this purpose.
- Battery room shall be painted with acid proof paint. Exhaust fans should be provided in the battery room. Contractor shall submit the details of the same to the owner.
- Battery room shall be corrosion proof type lamp and fixtures.
- The ripple content in the D.C. current shall be less than 1%.
- The float charger unit shall be capable of supplying continuous D.C. load and trickle charge the battery.
- Necessary alarm and indication shall be provided with the DC System and also in the annunciation window of the Battery Charger.
- Necessary terminals with lugs for earthing the charger panels with two distinct separate earthing for each panel shall be provided. In addition, separate terminals for earthing of equipment shall be provided. The charger panels shall have space heaters.
- Compression type cable glands of suitable rating for PVC unarmoured cable, suitably mounted in the panel for cable entry from the bottom for A.C. & D.C. supplies shall be provided.
- Type of cell, cell terminal, containers and installation of battery, chargers, inverter, DC Distribution Board, cables etc. should conform to the latest edition of relevant Indian Standard.
- During installation of battery, charging & discharging and charging is to be done proper installation procedure.

5.9.10.4 TECHNICAL REQUIREMENTS

Minimum technical requirements for the DC Battery, Battery charger and DC Distribution Board are as following.

- The battery shall be made of lead-acid cells with tubular type plates conforming to latest issue of IS 1651. The battery cells shall be high discharge performance (HDP) type.

- The capacity of 220 V D.C. batteries based on 10 hours discharge rate shall be selected to fulfill the plant's requirement. The contractor shall propose the same to the owner and decision of the owner will be final and bound to the contractor.
- The battery shall normally remain under floating condition with the charger supplying the normal continuous load. However, the battery shall be capable of supplying the load without fall of terminal voltage per cell below 1.85V (92.5% of rated voltage).
- The number of cells of the 220 volt battery bank at Main Control Room and required voltage at Local Control Room shall be chosen to suit the following conditions.
 - Nominal floating voltage per cell shall be between 2.15 and 2.21 V.
 - The voltage of each cell under floating conditions shall be of optimum value for its performance and maintenance in a healthy condition.
 - The voltage of the battery after meeting the D.C. load cycle shall not be less than 90% of the rated voltage. The manufacturer shall ensure safe operation of the battery after the aforementioned end voltage.
 - The voltage across the load shall not exceed 110% of rated value under charging conditions of the battery. To achieve this condition under quick charging, a blocking diode may be incorporated by the supplier in the charging equipment.
- The bidder shall clearly justify the choice of number of cells in the tender on the above lines and furnish any clarifications required by the owner.
- All cell terminals shall have adequate current carrying capacity and shall be of lead-alloy or lead-alloy reinforced with copper core inserts. Cell terminal posts shall be equipped with acid resisting connector bolts and nuts.
- The electrolyte shall be of battery grade sulphuric acid. The battery shall be transported dry.
- The charging equipment shall preferably employ solid state full wave rectifier in a 3 phase full wave bridge circuit with suitable filter circuit of AC ripples, suitable for operation in conjunction with static voltage regulator. A.C. and D.C. Circuit breakers with thermal overload and instantaneous short circuit releases shall be provided on input and output sides of chargers respectively.
- Capacity of the float charger and the boost charger in the float cum boost charger shall be sufficient to meet the system requirement. Contractor shall submit the details to the owner.

- The charger shall be capable of providing the floating voltage between 2.15 V to 2.21 V per cell with the variation of not more than +1% irrespective of input supply voltage fluctuations within +/-10%, frequency fluctuation within +/-5 % throughout its ampere rating with ambient air temperature range of -3°C to 40°C.
- The DC Distribution Board (DCDB) shall be free standing, self-supporting and floor mounting type. It shall be totally enclosed and compartmentalized. DCDB shall be made as per relevant Indian Standard.
- One equivalent capacity of Incomer provision shall be there to connect with existing DC system with a castle key interlock
- The Emergency Lighting Board supplying the emergency lighting requirement of the power house at A.C shall have an arrangement so that automatic changeover to emergency lighting in case of A.C. failure, is achieved through an inverter of suitable capacity. Normally, the inverter shall run on AC supply. In the event of failure of AC, the inverter shall automatically switch-over to DC supply and feed the selected emergency loads (lighting loads) at 230 V AC. On restoration of AC supply, the inverters load will automatically return to AC.
- The DC system shall have necessary control & protection arrangement which include but not limited to the following.
 - Auto/Manual selector switch
 - Digital D.C. voltmeter, ammeter
 - A.C. failure alarm
 - Ground fault relay and its annunciation
 - Double pole D.C. contactor of suitable capacity for annunciation
 - Triple pole A.C. contactor of suitable capacity for ON/OFF operation
 - MCCB and DC contactor of suitable capacity in output circuit of each charger to suit the operation requirements.
 - Indicating lamps, as required
 - Triple pole, A.C. circuit breaker of sufficient capacity to meet system requirements & capacity with overload and short circuit release for incoming A.C. supply to charger panel
 - MCB/MCCBs for A.C. supply to individual chargers
 - A.C. under voltage relay
 - A.C. voltmeter, ammeter etc.
- Nearest local control room from the main control room should be connected with 220 V DC from Battery Bank DCDB.

- 220 V AC/DC converter is to be provided in each isolated switchgear for operation of circuit breaker/isolator as and where required. Power required in ACDB/DCDB for illumination, control system etc. for each control room should be collected from 415 V (3phase+N) transmission line with necessary cables and protection.

5.9.10.5 APPROVAL

The Detailed Design Report submitted by the contractor to WBPDCCL must contain but not limited to the following details of the DC system:

- Detailed specification of all the items.
- Necessary Drawings
- Test Certificates etc.

Prior to the delivery of the product, the contractor shall submit but not limited to the following documents:

- Guarantees
- Instructions for installation and operation, manual
- Detailed schematic, connection and control wiring diagrams etc.

The contractor can deliver the product to the site only after receiving such approval against their prayer in writing from WBPDCCL.

5.9.11 RELAYS (For HT and LT Switchgear)

I. General- A

- a) All relays & timers in the protection circuit shall be flush mounted with connection from inside. They shall have transparent, dust tight covers, removable from the front. They shall have built-in testing facilities. Except small auxiliary relays and timers all relays shall be draw out type.
- b) Relays shall be rated for operation on 1A / 5A secondary current and 110V secondary voltage to be decided by the bidder. Number and rating of relay contacts shall suit the job requirements.
- c) The Bidder shall furnish, install & co-ordinate all relays to suit the requirements of protection, interlock. Application check shall be made on all protection relay. The result of such check shall be furnished for approval.
- d) It shall be the responsibility of the Bidder to fully co-ordinate the overload and short circuit tripping of the circuit breakers with the upstream and downstream circuit breakers to provide satisfactory discrimination.
- e) All setting devices shall be accessible after removing the front cover. No relay shall be mounted on the rear side of Switchgear panel.

- f) All relay coils and their auxiliary contacts (including un-enabled relays in Composite Numerical Relays, if any), including spare contacts will be wired up to the terminal blocks of respective panels for wiring to remote panel / PLC and for future use.
- g) Parameterization and loading and downloading of data shall be possible from local HMI as well as from remote panel / PLC.
- h) All numerical relays shall have front communication port for parameterization, loading and downloading of data through Laptop.
- i) All numerical relays and multi-functional meters shall be hooked up and connected with HMI through Fiber Optic cable.

II. General- B

- a) All protective relays shall be of numerical microprocessor based multifunctional type having communication facility.
- b) All relays shall conform to the requirements of IS: 3231 / IEC: 60255 standards. The Numerical relays shall have communication, Metering and monitoring facility.
- c) Bidder shall ensure availability of spare parts and maintenance support for the equipment for at least 15 years from the date of supply.
- d) Separate Master trip Lockout Relay shall be provided for all VCB, SF6, ACB operated HT and LT system.
- e) Any foreign relay manufacturer through his Indian partner or subsidiary company in India shall provide application, testing, commissioning and other necessary support for minimum 15 years. They shall also maintain adequate inventory of each type of relay or spares to meet the requirement arising during project execution and plant operation.

III. Technical Requirement

a) Auxiliary Power Supply

Unless otherwise specified, relay shall be suitable to accept both AC / DC supplies with range 110V to 240V with tolerance of $\pm 20\%$. The auxiliary power supply shall preferably be site selectable requiring no additional hardware.

b) Basic Requirement and Constructional Requirement

- i. Relays shall be suitable for flush mounting on the front with connections from the rear. The enclosure shall be dust tight having degree of protection minimum as IP: 52.
- ii. Relay shall have draw out feature with plug in type PCB for easy replacement. In case of fixed type relay, the terminals shall be easily accessible for testing and commissioning.
- iii. Relay shall have self-diagnostic feature with indication of relay failure on relay front. However, while diagnostic circuit runs, it must not interfere in the main protective relay circuit and allow working of main protective circuit continuously. Relay faults (self-diagnostic) shall be communicated and annunciated to HMI.
- iv. Design of the relay shall be such that it must operate selectively and with proper discrimination. It must be immune to any kind of electromagnetic interference. Vendor to submit all related type test reports for the offered model along with the offer.
- v. Necessary auxiliary relays, timers, trip relays, etc. required for complete scheme, interlocking, alarm, logging, etc. shall be provided. No control relay, which shall trip the circuit breaker when relay is de-energized, shall be employed in the circuits.
- vi. Numerical Relays shall have appropriate setting ranges, accuracy, resetting ratio, transient overreach and other characteristics to provide required sensitivity to the satisfaction of the Owner.
- vii. The internal clock of the system shall be synchronized through the GPS Time Synchronizing System.

c) Display & Indication

- i. All numerical relays shall have keypad / keys to allow relay settings from relay front. In addition, relay shall have front port for downloading / uploading of relay settings from the PC / Laptop. All hand-reset relays shall have reset button on the relay front. Relay to be self or hand reset shall be software selectable.
- ii. All relays shall have LED / LCD display for settings, status, faults and events. LCD display shall be backlit and temperature compensated up to 65°C for contrast and legibility.
- iii. As a minimum, the relay shall have LED indicating lamps for fault trip, relay healthy / unhealthy and control supply on.
- iv. The relay shall have at least 6 programmable LEDs on relay front.

d) **Software Security**

Relay shall be provided with password protection against unauthorized write access. However, viewing of metering data, settings, and status and event data as read only parameters should be without password protection. All software shall be user friendly and latest up to date version.

e) **Disturbance, Event Recording & Data Storage**

Status, disturbance data and events shall be stored in non-volatile memory or memory backed up by battery. It should be possible to store minimum 50 events with date and time stamp, last 5 fault records and last disturbance record. When auxiliary power fails, it should be possible to see the latest state of display when power is restored. Also, in case of power supply failure lock out status of the relay should be stored and kept in memory to allow the working of interlock logic properly on restoration of the supply.

f) **Trip Circuit Supervision & Lock out function**

- i. Relay shall have built in lockout function. Lock out feature shall be self reset or hand reset and shall be software selectable.
- ii. Relay shall have built in trip circuit supervision function.

g) **Input / Output Interface, Filters and Galvanic Isolation**

- h) Relay shall have at least 4 NO contacts each shall separately be programmable for either hand reset or self-reset. The contact rating shall be minimum 5A at 250V AC / DC.
- i. Relay shall be made immune to capacitance effect due to long length cables.
 - ii. All IOs shall have galvanic isolation. Analog inputs shall be protected against switching surges, harmonics etc.

i) **Serial Communication**

- i. Relay shall have RS485 or FO (Fiber Optic) port for serial communication.
- ii. All relays should be able to communicate with remote panel / PLC system. Data shall be available at the remote panel / PLC on request.
- iii. Protocol adapted for communication to remote panel / PLC should facilitate easy interface with worldwide used open protocol like Modbus or IEC 103 protocols.
- iv. It shall be also possible for Relay Parameterization as well Downloading of Disturbance Records from PC/ Laptop provided in Unit & Engineering Workstations located in Control Room of PWS. Necessary user friendly and latest

software to be provided for this purpose. Communication protocol shall be selected from relay to PC to provide all information.

- v. One (1) set of Laptop, loaded with common support software and which will allow easy settings of relays in addition to uploading of event, fault, disturbance records and measurement from relay front communication port. The Switchgear supplier shall furnish CD's for the above relay parameterization as well as download of disturbance recorder for all relays of his supplied switchgear. Accessories like table/chair/desk/power socket etc. as required for all PC/Laptop should be supplied.

5.9.12 PROTECTION SYSTEM

5.9.12.1 SCOPE

The scheme shall consist of design, engineering, quality surveillance, manufacture, tests at manufacturer's works before dispatch, transport, transit insurance, supply, delivery to site, storage at site, erection, testing, trial run and commissioning, handing over to the purchaser of protection system for

- PV Array yard
- Solar Inverter
- Three winding Step up Transformer
- Incomer feeder for 33 kV Switchyard
- Outgoing feeder for 33kV Switchyard
- Station Auxiliary Transformer

The protection system shall include protection relays, trip relays, relay contacts, trip & alarm circuits, Annunciation system, diagnostic system, other necessary equipment with all accessories, wiring and cubicles for making the protection system complete for 5 MW Floating Solar PV Power Plant in SgTPP, West Bengal.

5.9.12.2 STANDARDS

All materials and equipments shall conform to latest edition of relevant Indian/IEC Standards unless otherwise specified. Equipment conforming to any other authoritative standard ensuring equal or better quality than the standards indicated below will also be acceptable. However, in such eventuality, the salient points of difference between the standards adopted and the standards mentioned below shall be brought out by the bidder. The list of reference standards is given below:

Sl. No.	Standards	Description

1	IS: 2705	Current Transformers
2	IS: 3156	Voltage Transformer s
3	IEC: 60255 (Part 1 to 23)	Electric Relays
4	IEC: 60337	Control switches and low voltage switching devices for control and auxiliary circuits
5	IS: 1885	Electro-technical vocabulary on Electrical relays, Electric Power System Protection and Switchgear & Control
6	IS:13947	Degree of protection provided by enclosures for low voltage switchgear and control gear
7	IS: 3231	Electric relays for Power System protection
8	IS: 5834	Electric Timer relays
9	IS: 8686	Static Protective relays

5.9.12.3 TECHNICAL REQUIREMENTS

The technical requirements of the protection system shall be but not limited to the following.

- Protection shall be designed to ensure reliability, sensitivity and stability under through fault conditions of the system.
- The protection system shall be fully integrated with SCADA system.
- The protection scheme shall be coordinated with control & protection of solar modules, solar inverters and generator transformers etc. All protection, though not specified but which are recommended for this capacity of the machine as per relevant IEC / other Standards shall be provided.
- The protective relays shall be of the numerical, fully tropicalised, plug in type, arranged in protection cubicles including all ancillary devices, such as interposing transformers, tripping matrix and relays, test facilities, power supply units, etc. with all circuits complying to latest editions of IEC 60255-4 recommendation or British Standard 142 and 5992, parts 1, 2 and 3 or relevant Indian Standard. However necessary SAS integration provision shall be there.
- The relays/protection system shall be of state of the art of technology and only latest proven versions of the relay series shall be offered. If the protection system mentioned in the awarded Contract become obsolete at the time of supply, the Supplier shall offer the latest model with the approval of Employer, without any extra cost.
- Protection system shall be provided to prevent operation of protective equipment due to, magnetizing current inrush during switching-in of the transformer from the high voltage side.

- Precaution shall also be taken so that the unavoidable inductive and capacitive couplings from the power circuits do not cause disturbances.
- Protection relay shall have features but not limited to the following:
 - Man machine communication interface with alarm and trip value setting, displaying of alarm/trip set values, alarmed/tripped values, fault current and disturbance values etc.
 - Self-supervision and indication of any failure.
 - Continuous monitoring of external and internal auxiliary voltages
 - Easiness of replacing a set in case of failure.
 - Communication interfaces or ports.
 - Indication of alarm and trip condition.
 - Test facilities etc.
- All devices shall remain inoperative during external faults and transient phenomenon. They shall be insensitive to mechanical shocks, vibration and external magnetic fields.
- The protection relays, shall be located in conventional panels and shall be flush mounted in dust and moisture proof cases with protection class IP 54 and of the draw out type with rear connections. The protection class of the cover for all relays or protection systems, in which the modules are mounted, shall not be inferior to IP 54.
- The protection systems shall be fed by the battery banks installed in the main control room and local control rooms. Relay shall be suitable for operation on DC systems without the use of voltage dropping resistors.
- The supplier has to supply the equipments for protection of best quality. The supplier has to maintain control and quality assurance during the manufacture, installation, testing and commissioning of equipments as per approved quality assurance plan.
- Minimum protection functions to be provided for different type of circuits are listed below -

For 33kv Incomer feeder-

- a) 3 Nos. IDMTL over current (51) for phase fault
- b) 1-Definite time O/C relay (50 N/2) for earth fault.
- c) Under voltage with time delay (27)
- d) VT fuse failure

For Outgoing feeder-

- a) 3 Nos. IDMTL over current (51) for phase fault feeder
- b) 1-Definite time O/C relay (50 N/2) for earth fault.
- c) Under voltage with time delay (27)

For Transformer-

- a) 3 Nos. IDMTL over current (50/51) with high set instantaneous units for phase faults
 - b) 1 No. Definite time O/C (50G) for earth fault (through CBCT)
 - c) 1-Definite time O/C relay (50 N/2) for earth fault
 - d) Differential protection (for transformers rated 3MVA and above)
 - e) Restricted Earth fault (64) for Transformer LV side from transformer neutral including LV side Bus duct / cable.
 - f) Low vacuum alarm and trip.
 - g) Winding temperature alarm and trip.
 - h) Oil temperature alarm and trip.
 - i) Pressure relief device operated alarm.
 - j) Conservator oil level low alarm.
 - k) Buchholz protection.
- For switchyard necessary protection shall be given.

5.9.12.4 APPROVAL

The Detailed Design Report submitted by the contractor to WBPDCCL must contain but not limited to the following details of the protection system:

- Detailed specification of all the items.
- All required drawing etc.

Prior to the delivery of the products, the contractor shall submit but not limited to the following documents:

- Guarantees
- Instructions for installation
- Instruction O&M manual Testing & commissioning manuals
- Detailed BOQ covering protection relays, CTs /PTs, DC Sources and all other devices.

The contractor can deliver the product to the site only after receiving such approval against their prayer in writing from WBPDCCL.

5.9.13 EARTHING AND LIGHTNING PROTECTION SYSTEM

5.9.13.1 SCOPE

The scope of work under this specification covers the design, supply, transportation, delivery at project site, transit insurance, storage at site, erection, testing & commissioning of electrical grounding and lightning protection system along with necessary materials. All the equipment and building shall be protected from lightning through Lightning Protection System.

5.9.13.2 STANDARDS

The grounding system shall conform to the requirement of following standards.

Sl. No.	Standards	Description
1	ANSI/IEEE: 80 –2000	Guide for safety in AC Substation Grounding
2	CBIP Publication: 223	Design of Earthing Mat for High Voltage substation
3	IS: 3043	Code of Practice for Earthing Indian Electricity Rules

5.9.13.3 OBJECTIVE

The grounding system shall be designed with the following objectives:

- To provide low impedance path to fault currents, during ground faults, to ensure prompt and consistent operation of protective devices to effect isolation
- To keep the maximum voltage gradient during ground faults along the surface inside and around the switchyard, PV array yard, control rooms etc. within safe limits
- To protect the life and property from electrical shocks due to over voltage
- To stabilize circuit potentials with respect to ground and limit the overall potential rise

5.9.13.4 TECHNICAL REQUIREMENTS

Minimum technical requirement of the earthing system is mentioned below.

- The earth resistance should be less than 1 Ω .
- Suitable number of earthing pit shall be provided at the array field.
- Design and installation of the earth mat and other associated system shall confirm IS: 3043 and shall be followed by modern practice.
- The earthing for solar field and power distribution system shall be made with GI pipe of suitable size including accessories, and providing masonry enclosure with cast iron cover plate having locking arrangement, watering pipe using charcoal or coke and salt as required as per provisions of IS: 3043. The Mounting structure shall be grounded properly using GI strips and maintenance free earthing kit.

- Size of ground earth mat shall be 1000mm below FGL and 40 mm dia MS rod
- Necessary provision shall be made for bolted isolating joints of each earthing pit for periodic checking of earth resistance.
- The earth conduction shall run through GI pipe partly buried and partly on the surface of the control room building.
- The complete earthing system shall be mechanically & electrically connected to provide independent return to earth.
- All three phase equipment shall have two distinct earth connections.
- Along the cable trays suitable size of GI Flat shall be provided inside the control room.
- For each earth pit, necessary Test Point shall have to be provided.
- The earthing system shall be connected to the following.
 - Solar modules with suitable number of earthing pit at the solar array field
 - The neutral point of each system/equipment
 - Equipment framework and other non-current carrying parts
 - Frames of panels & cubicles
 - Metallic structures of switchgear, cable racks, casing of cable boxes
 - Equipment supporting Steel structures
 - All extraneous metallic frame work not associated with equipment
 - The earth point of lightning arrestors; voltage transformers and lightning conductors through their permanent independent earth electrodes.
 - Fence
- For equipment connection to mat/riser, 50 mm x 6 mm or higher size GS flat shall be used.
- Each neutral point of transformer shall be provided with two separate treated earth pit through 80 mm dia GS perforated pipe having 3 mtr depth. Necessary charcoal, salt etc. to be provided for earth pit as per relevant standard. Each earth pit shall be connected with Main earth grid through a bolted type test point.
- Separate grounding grid to be provided for electronic earthing for PLC / DCS system with earth resistance 0.5 Ω . (Refer NIT Drawing SG-FLSP-DWG-E-003-Model).

- The conductor shall be of adequate cross-section to safely withstand the system fault current for time duration of fault clearance by the remotest/back up protective system.
- Sufficient allowance needs to be provided for corrosion of the embedded conductor on account of chemical properties of soil and also due to galvanic action with other embedded systems.
- For determination of the size of the conductor, the value of fault current may be taken as 40 kA; duration of fault current may be considered as 1 second. The extra allowance of 20% to take care of corrosion shall be added to arrive at final conductor size.
- For designing of the earth mat for 33kV switchyard, the material of ground mat conductor shall be 40 mm MS rod and that of risers emanating from ground mat shall be GS flats. Soil resistance of the site is available in the soil report.

Lightning Protection System:

Lightning protection work shall be carried out in compliance to the following standards/codes. All standards, specifications and codes of practice (COP) referred to herein shall be the latest editions including all amendments and revisions as on the date of opening of bid. In case of conflict between the specification and those standards/codes referred to herein, the former shall prevail:

- Indian Electricity rules
- National Electrical Code
- COP for the protection of building and allied structures against lightning : IS 2309
- Recommended practice for hot-dip galvanizing of iron and steel: IS 2629
- Method of testing uniformity of coating on zinc coated articles : IS 2633
- Methods for determination of mass of zinc coating on zinc coated iron and steel articles : IS 6745
- IEEE guide for instrumentation and control equipment grounding in generating stations : IEEE 1050;
- Lightning protection will also be provided for building/ structures where the overall rise factor exceeds 10^{-6} as per IS: 2309

5.9.13.5 APPROVAL

The successful bidder shall carry out the earth resistance measurement at the site and they need to submit the measurement report to WBPDC.

The Detailed Design Report submitted by the contractor to WBPDCCL must contain but not limited to the following details of the earthing system:

- Detailed specification of all the items.
- Soil resistivity measurement data
- Necessary calculations and drawings etc.

The successful bidder required to produce schematic diagram of the earthing system and the proposed locations for earth mat as per relevant standard with the Detailed Design Report.

All drawings and calculations submitted by the contractor will be subjected to approval of the WBPDCCL.

5.9.14 CONTROL, MONITORING AND DATA ACUSITION

5.9.14.1 SCOPE

The scope of work under this specification covers the design, engineering, manufacture, testing at manufacturer's works, transportation, transit insurance, delivery at project site, storage at site, erection, testing at site and commissioning of Control, monitoring & Data Acquisition system comprising of computers, VDU, key board/mouse, SCADA System, PLC's, input and output relays, meters, fields sensors, panels/cubicles for housing above equipment/devices, power supplies, transducers, converters, wiring etc to make the system complete.

5.9.14.2 REQUIREMENTS

- ❖ The existing 5MW solar PV plant is being controlled from maxDNA based SCADA system, placed inside the existing inverter cum main floating solar control room, supplied by BHEL. Total operation, control & monitoring of the existing switchgear is done from the same SCADA system.
- ❖ Bidder may provide separate SCADA system for collection of data from inverters and other equipment via soft connectivity for remote control and monitoring of total solar PV plant.

However, electrical switchgear that shall come under bidder's scope shall be hardwire connected with existing DCS as mentioned below.

- ❖ Remote control/operation/monitoring of all new electrical breakers that will be supplied by the bidder under battery limit of this project, is to be done from the same existing BHEL supplied maxDNA based SCADA system.

- i. Additional spare IOs have been kept in the existing DCS for this purpose. Allocation of IOs in the DCS panels shall be done by the bidder during detail engineering. However, if any extra module is required that will be supplied by the bidder.
 - ii. Bidder has to supply cables, JB and all other hardware accessories, as required, for hooking up of these signals to the existing DCS.
 - iii. Laying and termination of cables in DCS panel terminal block for hooking up of these signals in the existing DCS is under Bidder's scope of work.
 - iv. Bidder shall also modify the HMI pages and implement all the logics in the existing DCS accordingly for integrated automatic operation of the total switchgear.
- ❖ Bidder supplied SCADA system shall be interfaced with existing maxDNA SCADA system, so that all solar plants can be monitored from existing workstations also.
 - ❖ The automatic control panels shall be located in each control room. The control panels shall be provided with local automatic selection. On local automatic selection, control will be transferred to control panels located in local control rooms from where unit can be started by single push button control.
 - ❖ SCADA system with all hardware & software for integrated operation of total Solar PV Plant is to be provided.
 - ❖ SCADA system shall have data logging and display system for continuous monitoring of data.
 - ❖ In addition to the real time trend, SCADA shall also have provision for offline viewing and retrieving of historical data of all parameters. All the trend and cumulative graphs shall be able to view and store. Also all the events including outages and faults shall be logged and stored with time and date stamped. SCADA should also have provision for offline viewing of daily, monthly and annual average of all the parameters.
 - ❖ SCADA system shall have redundancy w.r.t. processor, communication, power supply at all level.
 - ❖ Bidder shall provide two nos. Engineering cum Operators' Work Station cum Historian. Bidder shall also supply a network printer.

- ❖ HMI peripherals shall be kept inside main control room beside raw water pond no. 3. Total solar PV plant shall be controlled from there.
- ❖ SCADA Communication Network shall have redundancy at all level.
- ❖ SCADA system shall be OPC compliant.
- ❖ UPS system to be provided to meet the power requirement of Bidder supplied SCADA system as well as CCTV system.
- ❖ SCADA system hardware, UPS system, HMI peripherals etc. shall be kept in A.C. humidity controlled environment.

If any remote IO panel of SCADA system has to be installed in new inverter rooms, then bidder shall provide air conditioned environment for the same.

- ❖ The SCADA shall have the feature to be integrated with the Network system as well as remotely via the web using either a standard modem or a GSM/WIFI modem. The contractor shall provide compatible software and hardware so that data can be transmitted via standard modem.
- ❖ The SCADA work station and push button control panel shall be interlocked by means of hardwired and software (Logic) to ensure smooth and safe operation of the plant.
- ❖ All pre-synchronisation checks shall be made to ensure normal and safe operation of the machine. Detailed philosophy shall be submitted by the contractor.
- ❖ System shall acquire on continuous basis the parameters of PV array, like DC current of string, DC voltage of each combiner box etc., Parameters of Solar Inverter like Power at the input of each inverter, Power at the input of each inverter, phase current, voltage, PF, MVAR, MW, Frequency etc., similar parameters of Generator Step-up and auxiliary Transformers etc.
- ❖ The Monitoring system shall perform String level monitoring for trouble free operation and maintenance of the plant. System shall indicate these on VDU Mimic alongside relevant device.
- ❖ System shall monitor and indicate on VDU status of all electrical devices including all switchgear.
- ❖ Shall provide mimics of main single line diagram, Auxiliary SLD and DC SLD in colour. The parameters as above shall be displayed by the side of respective device in proper units of measurement.

- ❖ The control & monitoring system for the generating units shall be microprocessor based digital control.
- ❖ The data logger shall have reliable battery backup and data storage capacity to record all sorts of data simultaneously round the clock.
- ❖ Inverters should be integrated with SCADA and provision of Data logging should be there. Logger should have the provision of recording the data of solar insolation, PV Module temperature and ambient temperature and associated electrical parameters at different stages to study performance of system as well as to study status of the system at a particular instant. The data logger should have required transducer to monitor and record the required system data. The data logger should be provided with an insolation sensor and a module temperature sensor, ambient temperature sensor matched with the system.
- ❖ Plant based Remote Monitoring system must be compatible with data logger. The other required accessories, hardware and compatible software shall have to be provided as an integrated part of the system to monitor the real time data through the server. The Data logger shall continuously send data to the server. Plant based Data logging system may be provided with special software (minimum 10 users). Upgradation of the software, if any, shall be done by the contractor. The server shall not be provided by WBPDC or end-user.
- ❖ In case the data cable to be laid in the array field, SPD (surge protection device) suitable for communication network, as much number at suitable location are required must be provided with the system.
- ❖ The Plant based monitoring system should have the provision of graphical representation of the data shall include but not limited to the following:

SI. No.	Operating Parameter	Desired specification
1	Input data	PV Power PV Energy
2	Meteorological data	Insolation (inclined on the plane of module as well as horizontal) Module Temperature Ambient Temperature Wind Velocity
3	Output data	Inverter Export Power Inverter Export energy

- ❖ All data shall be recorded chronologically date wise. The data file should be MS Excel/XML/any readable form compatible and should have the facility of easy downloads.

- ❖ IT grade server may be installed including provision for back up data at least for 02 years. Copper cable, Cat6 cable and fibre optic cable and other hardware as required for interconnection and complete commissioning of SCADA system and complete commissioning of solar PV power plant shall be supplied by the bidder.
- ❖ Bidder shall supply proven latest version of hardware and software available at the time of system designing. All software (supplied for the project by the bidder) user licenses shall be valid for entire life of power plant. User should not have to pay any recurring license fee during the usage period of the system. In case of future up-gradation of software, Bidder shall remain committed to upgrade the supplied system at per with the new version within the warranty period and ensure successful integration of the system without any additional cost to owner. Beyond the warranty period and during the remaining life of the plant, any up-gradation in hardware and software shall be brought to the notice of Owner indicating whether it shall be possible to upgrade the system by partially replacing, modifying and/or patching of hardware /software.
- ❖ Also user license for all the software shall not be machine specific. That is, if any hardware / machine is upgraded or changed, the same license shall hold good and shall not be necessary for owner to seek a new license/renew license due to upgradation/change of hardware/machine in system at site.
- ❖ Password security shall be provided in order to ensure security level to the plant operation.

5.9.14.3 CCTV SURVEILLANCE SYSTEM :

- ❖ PTZ (Pan-Tilt-Zoom)/CCTV outdoor/indoor cameras covering the whole plant (nos. of cameras requirement shall be as per design for well coverage of the plant) and total Inverter cum Control Room to be deployed with night vision and central monitoring through 42" LED monitor/TV at control room.
- ❖ Plant monitoring through CCTV system shall be done from existing main control room beside raw water reservoir no. 3. So, CCTV system shall be placed inside main control room.
- ❖ Bidder shall supply power supply cable, FO cable, CAT 6 cable, all types of cable connectors for the above cables and other hardware accessories, as required for CCTV system.

- ❖ CCTV system shall be powered from UPS ACDB. The system to be installed with the following Specification:

Technical specification of CCTV surveillance system

Technical Specification	
1/3 -inch, CCD / CMOS sensor IP Box/Bullet outdoor type HD 1080p True Day/Night Switching IP Camera UL listed with VF lens 3.3 to 12 mm, two way audio and audio alarm, WDR 65db or more ,IP, Onvif profile	
Video compression	Two Simultaneous individual configurable H.264 Stream at 1080p 30fps. Camera Must support 2 Regions of interest and Remote E-PTZ, Motion, tamper and audio detection.
Image format	
Active Pixels	1920 x 1080 with aspect ratio 16: 9
Video Resolution (H x V)	1080p, 720p,
Sensitivity	Min. 0.3 lx, 0.0 lx (IR active)
Shutter	Automatic Electronic Shutter (AES) Fixed (1/30 [1/25] to 1/10000 or better
Lens	Varifocal 3.3 to 12 mm, DC Iris
Wide Dynamic Range	65db or more
Audio Communication	Two-way, full duplex
IR LED /Illuminator	LED high efficiency array, 850 nm
Night Vision distance	25m
Protocols	IPv4/ IPv6, UDP, TCP, HTTP, TTPS, RTP/RTCP, IGMP V2/V3, ICMP.
Ethernet	10/100 Base-T, auto-sensing, half/full duplex, RJ45
Connectivity-Onvif profile,	auto-MDIX
Operating Temperature	-10°C to +55°C with housing
Ingress and impact	Protection IP66
True Day/Night	Auto, Color Monochrome
Certifications	CE, FCC and UL
Video Management System Software (VMSS)	The Windows based video management system (VMS) specified shall be client/server based IP video security solution that provides seamless management of digital video and data across an IP network. System is designed to work with own CCTV cameras and Onvif profile compliant 3rd party products.
Display System	42" LED HD (1920 x 1080)
Data Storage Server	<ul style="list-style-type: none"> i. Data Base Server – Designed as per system requirement for smooth operation ii. OS - Windows Storage Server latest available, iii. Colour Monitor - 21" Flat Panel LED Monitor iv. RAM - 4GB DDR2, 667MHz SDRAM(minimum) v. Memory - 2 TB HDD(minimum) vi. Graphic Card - Integrated Intel Graphics Media Accelerator X3100 vii. Two(2) PCI-X and Two(2) PCI-Express Expansion

Technical Specification	
	Slots viii. 2/4 USB, 2 serial, and 2 VGA Adaptor, ix. CD/DVD ROM.; USB Keyboard and Mouse x. Dual Channel Internal Ultra320 SCSI xi. Integrated RAID-1 with hot-spare xii. Dual Integrated 10/100/1000 Ethernet NIC xiii. I/O Expansion Option xiv. Should be with Antivirus and Firewall complete in all respects as per specifications as required.

5.9.14.4 TECHNICAL SPECIFICATION OF HMI PERIPHERALS :

Sl. No.	Description		Minimum requirement
Engineering cum Operator's Work Station cum Historian			
i.	Processor	:	Latest, minimum Intel Core i5 quad core
ii.	Configuration	:	Tower
iii.	Internal clock	:	3.2 GHz (min.)
iv.	Architecture	:	32 bit
v.	Video Card	:	PCI
vi.	RAM	:	4 GB (Minimum) DDR
vii.	Hard drive	:	1TB SATA (7200 RPM)
viii.	Cache	:	512 KB Level 2
ix.	CD/DVD Drive	:	DVD-Both Read & Write for OWS. Both DVD Read & Write for EWS
x.	Audio controller	:	16-bit
xi.	Operating system	:	windows 8.1 Professional downgraded to Windows 7 Professional 64 bit or latest at the time of detailed Engineering/procurement
xii.	Graphic accelerator	:	8MB (min.)
xiii.	Communication ports	:	(a) RJ-45 NIC- 02 Nos. (b) USB ports – 04 nos. (min.) (c) USB 3.0 - 02 nos.
xiv.	Accessories	:	USB Keyboard, USB Mouse
Monitor for Work Stations			
i.	Type	:	LED
ii.	Screen diagonal	:	24"
iii.	Display	:	Full HD

Sl. No.	Description	Minimum requirement
iv.	Resolution	: 1920 X 1080 or better
v.	Degree of protection	: IP-30
vi.	External Controls	: Brightness, contrast, Horizontal / Vertical amplification & shift
vii.	Power supply	: 240 V, 50 Hz, 1 phase
viii.	Ambient temperature	: 0-50 C
ix.	Humidity	: 95% non-condensing
x.	Version	: To suit industrial application (latest version as per availability at the time of detailed Engineering/ procurement
Color Laser Printer		
i.	Type	: Electro-photographic laser, tabletop
ii.	Printer Memory	: 512 MB (min.)
iii.	Speed	: Monochrome 24 ppm - A4, Color 6 ppm - A4
iv.	Resolution	: 1200 x 1200 DPI in color
v.	No. of color (Basic)	: 4 (four) minimum
vi.	Duty cycle	: Monochrome 75000 pages / month
vii.	Power supply	: 240V AC, 50 Hz, 1 phase UPS
viii.	Ambient temperature	: 0-50°C
ix.	Humidity	: 95% non-condensing.
x.	Interface	: USB and Ethernet (RJ45)
xi.	Size of paper	: A4
xii.	Print media	: Plain paper, transparencies, thick stock, glossy stock, envelopes
xiii.	Special Features	: 1) Automatic Two-sided printing. 2) Built in Networking with Fast Ethernet 10/100 Base-T network port.
xiv.	Accessories	: Connector & Cable

5.9.14.5 CONTROL DESK & FURNITURE

Bidder shall provide a control desk and complete set of furniture as required to place HMI peripherals supplied by them. Bidder shall provide ergonomically &

aesthetically designed control desk, chair etc. from reputed manufacturer especially designed for computer peripherals.

The set of furniture shall include but not be limited to control desk, chair, printer table, computer tables etc.

All the above furniture shall have permanent Modular type power receptacles of ISI standard having five Plug points (15Amps rated) with individual isolation switches. Permanent I/O receptacles shall be provided."

5.9.14.6 TECHNICAL SPECIFICATION OF UNINTERRUPTED POWER SUPPLY (UPS) :

UPS system to be provided to meet the power requirement of bidder supplied SCADA system, HMI peripherals as well as CCTV system.

UPS alarms shall be monitored remotely from working stations in control room.

UPS system shall have with 2x100% configuration, normally both will run in parallel mode sharing 50% load. On failure of any UPS, its load shall automatically get transferred to the other healthy UPS.

The UPS system shall meet the following minimum specifications.

1.	Type	:	IGBT based high frequency PWM technology of latest proven design.
2.	Configuration	:	2 X 100% parallel redundant chargers and inverters, (2 X 100%) battery bank, bypass line transformers & voltage stabilizers, static switch, manual bypass switch and power distribution board.
3.	Charger	:	Solid state silicon controlled full wave rectifier designed for single and parallel operation with battery and shall have automatic voltage regulator, current limiter and filter circuits. Charger shall have provision for float, equalizing and boost charging.
4.	Charger output Regulation	:	± 1% from no load to full load with input power supply variation of 10 % to -15% in voltage and ± 5% in frequency with output ripple content less than 2%.
5.	Battery	:	Ni-Cd vented type, pocket plate high discharge battery of adequate capacity to meet the requirement of UPS, generally conforming to IS-10918. Sizing calculation shall be furnished

6.	Backup time	:	1 hour in case of input power fail.
7.	Inverter capacity	:	To be decided by bidder. 25% extra capacity margin to be considered.
8.	Overload capacity	:	a) 125% for 10 minutes b) 150% for 60 seconds
9.	Sizing	:	a) Environmental temperature 0 to 50 degC. b) Power factor of load - 0.8 c) Adequate I ² t capability to clear fault in the maximum rated branch circuit. d) UPS shall be capable to operate without DC battery in circuit and under all conditions of load. e) In case of failure of a charger / input power, other charger whose input supply is healthy shall be capable to charge the battery and as well supply input power to inverter. No discharge of battery is allowed. f) Inrush current
10.	Inverter Output Regulation	:	a) Voltage- 240V ± 1% b) Frequency- ± 0.5% c) Power factor of load - 0.8 d) Transient voltage regulation (on application /removal of 100%load) – better than ± 20 %. e) Recovery time from transient to normal – 50 msec.
11.	Harmonic	:	a) Sine wave output b) Total harmonic content- 5% (maximum) c) Content of single harmonic- 3% (maximum)
12.	Efficiency	:	a) 100% Full load- 85% b) 50% load-80%
13.	Synchronization limit	:	Between inverter & standby AC source shall be within 47 Hz to 53 Hz field adjustable. Inverter shall remain synchronized with the AC mains.

14.	Inverter protection	:	Overload, short circuit and 100% loss of load.
15.	Load sharing	:	50% by each inverter in normal parallel operation. In case of failure of either inverter, 100% load shall automatically transfer to other inverter without any degradation of the UPS power quality. Power shall be transferred to the standby AC power without a break in synchronization if within limit in case of failure of both inverters. Asynchronous transfer to standby AC source in case inverters are being out of synchronism limit with AC mains.
16.	Static switch	:	Transfer UPS load to standby AC power in case of failure of both inverters. Transfer UPS load to standby AC power in case of failure of a inverter.
17.	Voltage stabilizer & Transformer	:	Solid state with regulation $\pm 1\%$ with efficiency greater than 95%. Overload capacity of transformer / stabilizer shall not be less than 300% of steady state for 200 msec.
18.	Diagnostic alarms	:	On panel & potential free contacts for interface to PLC
19.	Spare feeders	:	25%
20.	Accessories	:	Power distribution board, Voltage & current meters, power factor meter, KVA, frequency, panel alarms, switches etc.

5.9.14.7 OPTICAL FIBER CABLE

- ❖ Communication cable outside control room must be FO cable.
- ❖ This specification defines the minimum general requirements for the Design, manufacture, supply, inspection, installation, testing & commissioning of optical fiber cables and accessories, such as fiber distribution (patch) panels, adapters, connectors, joint boxes, pigtails and other components, as required

to complete the system. Bidder shall consider all related activities, such as cable stripping, cable entry in boxes and panels, cable fiber splicing/fusion, cable performance testing and other services, to achieve a properly documented and operational cable network. all Fibre Optic cables shall be Single Mode type.

- ❖ Fiber Optic Cables shall be installed on cable tray, duct bank, cable trench installation as necessary. For outdoor applications the cable shall be armoured with Poly Ethylene sheathing. In all cases cable shall be routed through suitable grade HDPE permanently lubricated protection pipe as per IS 4984, IS 12235 & TEC.G/CDS-08 /01of suitable size @ 53% fill factor. Permanent route marking in FRP (Fibre Reinforced Plastic) material shall be provided at intervals not exceeding 5 meters for all FO cables laid through buried/trench/ trestle during detail engineering.
- ❖ The Optical Fiber core shall be of ultra pure fused silica glass coated with UVcured acrylate suitable to withstand temperature of about 80°C (continuous).
- ❖ Fiber optic cable shall be of loose tube design. Typically, fibers shall be housed in-groups of 6 (minimum) within gel-filled buffer tubes to protect against ingress of moisture and vibration. The tubes shall be manufactured with industry standard material like Poly-Butylenes Terathylate (PBT). They shall be colored for easy identification. Buffer tubes shall be approachable with industry standard tools and practices. The buffer tubes shall be stranded around the Central Strength Member utilizing Reverse Oscillating Lay (ROL). Blank fillers shall be used as necessary to maintain circular cable structure. The fiber optic cable shall withstand water penetration when tested with a one meter static head or equivalent continuous pressure applied at one end of a one meter length of filled cable for one hour. No water shall leak through the open cable end.
- ❖ The central strength member of the cable shall be Fiberglass Reinforced Plastic (FRP) or other material with equivalent mechanical strength to provide both tensile and anti buckling strength to the cable.
- ❖ In addition to central strength member, additional strengthening substance like aramid yarns shall be helically applied over the cable core to provide additional tensile strength to the cable.
- ❖ The cable shall be of dual jacket & armoured. Inner sheath consists of a medium density polyethylene (MDPE) jacket extruded over the cable core.

- ❖ Two highly visible ripcords are placed under the jacket to aid in sheath removal. A co-polymer coated steel tape is corrugated and wrapped around the inner jacket to provide additional cable compression strength and rodent protection. The armor is covered with an outer black FRLS MDPE jacket. A ripcord is also placed underneath the armor for easy outer jacket removal.
- ❖ Minimum bending radius shall be equal or more to 15 D (D= Diameter). A continuous strength member shall be provided for the entire length of the cables. Every tube and fiber shall be colour coded to provide easy identification. The outer sheath shall be marked to show fiber type and cable classification at suitable intervals.
- ❖ The entire length of each cable shall be marked with the following items:
 - Manufacturer’s Name
 - Month and year of manufacturing
 - Coded description of the cable based on Telcordia’s (Bellcore) SR-2014 Suggested Optical Cable Code (SOCC).
 - Sheath Identification Number
 - Sequential Length Marking in meter
 - A Telephone Handset symbol to distinguish communication from power cable as per NESC section –35 G.
- ❖ Fiber optic cable shall provide a long life expectancy of minimum 25 years and shall meet the industrial standard of operation at temperature of 55 deg C and humidity to 100% without degradation to optical or mechanical performance.
- ❖ Optical fiber used in the plant shall generally conform to the following specification.

i. SPECIFICATION FOR G.652 MONOMODE FIBER

ATTRIBUTES	VALUE
1. Cladding Diameter	: 125µm ± 1.0µm
2. Cladding non-circularity	: ≤ 1.0%
3. Attenuation Coefficient at	
(a) 1290 nm to 1340 nm	: < 0.36 dB/km
(b) 1525 nm to 1575 nm	: < 0.25 dB/km
4. Chromatic Dispersion Coefficient at	
(a) 310 nm	: < 3.5 ps/nm.km
(b) 1550 nm	: < 18 ps/nm
5. Polarization Mode Dispersion (PMD)	: ≤ 0.5 ps/√km

6. Mode Field Diameter at	
(a) 1310 nm	: $9.2 \pm 0.4 \mu\text{m}$
(b) 1550 nm	: $10.50 \pm 1.0 \mu\text{m}$
7. Mode Field Concentricity Error	: $\leq 0.5 \mu\text{m}$
8. Proof Test	: $\geq 1\%$
9. Fiber Curl (ROC)	: $\geq 4.0 \text{ m}$
10. Macro-bend Test on Fiber at 1550 nm	: $\leq 0.1 \text{ dB}$

ii. CABLE ASSEMBLY

- ❖ Optical Fiber Environmental Splice Enclosure
- ❖ Optical fiber environmental splice joint enclosures shall be re-enterable and rack / wall mountable. The interior splice case shall be equipped to mechanically accommodate single-mode optical fibers connected by the fusion method. Splice case shall be equipped to organize the splice trays and the required service loops of buffered incoming optical fibers and outgoing 'pigtailed' in such a way that allows each completed splice and associated optical fiber to be maintained in an unstrained configuration. Splice enclosure shall be dust and weather proof.

iii. Fiber Optic Distribution Patch Panel

- ❖ Fiber optic distribution panels shall be provided as required. The fiber optic distribution panels shall be of a standard wall mounted sheet metal enclosure type. Fiber optic distribution panels shall be equipped to secure optical fiber patch cables and pigtails to prevent damage during all operation and maintenance functions. In general splice enclosure are envisaged. However,
- ❖ If no optical fiber splice enclosures are implemented, than the fiber optic distribution panels shall be equipped with splice trays for storage and protection of fusion splice connections of single-mode fiber optic cable and pigtails. Each fiber optic distribution panel shall be fully equipped with 'SC' type bulk head connector sleeves or equivalent. Unused sleeve ports shall be equipped with reusable caps to prevent the intrusion of dust.

iv. Pigtail and Patch Cord

- ❖ All pigtails shall be factory SC-connectorized, and satisfy specified performance for optical links. All unused pigtails (including spares) shall

be terminated with the connector to a bulkhead connector sleeve, protected by a reusable cap on the opposite sleeve port, to prevent the intrusion of foreign material or dust. All necessary connectorized pigtailed shall be provided in the lengths required.

v. Tests

- ❖ Following minimum test as per any approved standards shall be carried out on the cables
 - a. Attenuation and Dispersion Characteristics Tests
 - b. Proof Tests
 - c. Macro-Bend Resistance Test
 - d. Mechanical Tests
 - e. Low And High Temperature Cable Bend Test
 - f. Impact Resistance Test
 - g. Compressive Strength Test
 - h. Tensile Strength Test
 - i. Cable Twist Test
 - j. Cable Cyclic Flexing Test
 - k. Environmental Characteristics Test
 - l. Temperature Cycling Test
 - m. Color Permanence Test Cable Aging Test
 - n. Water Penetration Test
 - o. Lightning Test
 - p. Routine Test / Sample Test
 - Site Test (Like Continuity & Attenuation)

5.9.14.8 APPROVAL

The Detailed Design Report submitted by the contractor to WBPDCCL must contain but not limited to the following details of the data acquisition and monitoring system:

- Detailed scheme
- Details of panels, metering system
- Necessary drawings for the scheme etc.

Drawings and scheme submitted by the contractor will be subjected to approval of the owner.

5.9.15 CABLES & CONDUCTOR:

5.9.15.1 SCOPE

The scope of work under these specification covers the Design, Manufacture, Assembly, Shop Testing, Delivery at site, transit insurance, Storage, Erection, Testing & Commissioning of power, control and instrumentation cables (complete with cable terminals and all accessories for making the systems complete and for warranting a trouble free and safe operation).

The scope shall also include supply of all material, fabrication and erection of cable supporting structure, cable trance, cable racks & trays as well as laying of cables on cable racks.

The scope of supply shall also include necessary spares required for a period of 5 (five) years & special tools & plants required for erection & maintenance.

5.9.15.2 STANDARDS

The equipments covered under this chapter shall comply with the requirement of latest edition of following IS/BS/IEC specifications as amended up to date except where specified otherwise.

Sl. No.	Standards	Description
1.	IEC 60529/IEC 60502	All cables that are submerged or in contact with water should be with IP 68 rating.
2.	IS: 7098 – Part 1	Cross linked polyethylene insulated PVC sheathed cables for working voltage up to and including 1.1kV
3.	IS: 7098 – Part 2	Cross linked polyethylene insulated PVC sheathed cables for working voltage from 3.3kV up to and including 33kV
4.	IS 10418	Drums for cables
5.	IS 8130	Conductors for insulated electric cables and flexible cords
6.	IS 8308	Compression type tubular inline connectors for aluminium conductors
7.	IS 8309	Compression type tubular terminals for aluminium conductors
8.	IS 8438	Moulds of cast resin based straight joints of cable up to including 1.1kV
9.	IS 11967	Specifications for co-axial cables
10.	IS : 2062	Structural Steel (Standard Quality)
11.	IS : 513	Cold rolled low carbon steel sheets & strips
12.	IS : 277	Galvanized sheet steel
13.	IS : 808	Rolled Steel Beam, Channels and Angle section
14.	IS : 2629	Recommended practice for hot dip galvanizing of iron and steel.
15.	IS : 2633	Method of testing uniformity of coating on zinc coated articles.
16.	IS : 800	Specification for use of structural steel in general building construction.

Cables and other accessories complying with other internationally accepted standards such as IEC, IEEE, BS, etc. will also be accepted if they ensure performance and constructional features equivalent or superior to standards listed above. In such a case the Contractor shall clearly indicate the standard/standards adopted and furnish a copy of English version of the latest revision of the standard(s) along with the Bid and the salient features of comparison shall be brought out.

5.9.15.3 GENERAL REQUIREMENTS

Minimum requirements are mentioned hereunder.

- The cables shall be of type and design with proven record of similar power station installations.
- The colours of the cables (both AC & DC) should be so selected that there should not be any problem for identification of cables used for various circuits during inspection & testing.
- To facilitate easy identification of cores, multi-core control and instrumentation cables shall be colour coded by using PVC insulation of red, black, yellow, blue and grey colours in accordance with IS 1554 (Part I).
- Cable lengths shall be considered in such a way that straight through cable joint is avoided.
- Cable terminations shall be made with suitable cable lugs & sockets etc, crimped properly and passed through brass compression type cable glands at the entry & exit point of the cubicles.
- Cables shall be shipped in non-returnable drums, adequately braced, and with cable ends adequately sealed to prevent ingress of moisture.
- The contractor shall ensure that no bimetallic action takes place between the Aluminium conductor of the cable and the cable connecting lugs by filling the lugs with suitable compound.
- For the main cable ways, a system of cable racks and trays as well as cable ducts and trenches shall be provided. The power and the control cables will run on separate trays. The cables for emergency lighting, fire alarm systems, etc., shall run on separate trays. The power cables shall be laid on the uppermost rack to prevent spread of fire.
- In indoor installations, the cables must be laid through PVC conduit or GI pipe. In case of using metallic pipe as conduit proper grounding of the conduit must be done.

- Different voltage grade cables will be laid in separate trays when trays are run in tier formation. Power cables will normally be on top trays and control/instrumentation cable on bottom trays.
- Exposed cables, wherever, used, shall preferable have UV resistant jacket besides being water resistant.
- Cables for each equipment must be tagged with permanent metal tag of impregnated cable number as per drawings at MCC/switchgear end and equipment terminal end as well as in the mid portion of the cables at certain distances as instructed by the owner or his authorized representative.
- The loop length shall be provided for various cables as per the relevant Indian Standard.
- All types of cables shall have at least 10% spare cores.
- Cables shall be properly clamped at regular intervals with the help of non magnetic/molded fiber glass strip clamps/PVC sleeved clamps, of suitable size.
- When power cables are laid in the proximity of communication cables, the minimum horizontal and vertical separation between them may be 300 mm.
- Proper sealing arrangements at the points of cables entering the enclosures should be incorporated. Although not mandatory, manufacturers are however encouraged that the cables entering into the enclosures be sealed with modular EPDM based cable sealing and protection system based on multi-diameter technology.
- Cable selection criteria: In cable sizing the following are to be taken into consideration.
 - Short circuit current and duration
 - Continuous current.
 - Installation conditions.
 - Voltage drop under normal running and starting condition.
- Cable identification: Cable identification shall be provided by embossing on every meter

5.9.15.4 TECHNICAL REQUIREMENTS FOR CABLES AND CONDUCTOR

Minimum Technical requirements are mentioned below:

- All cables and connectors for use for installation of solar field must be of solar grade which can withstand harsh environment conditions including High temperatures, UV radiation, rain, water, humidity, dirt, burial and attack by moss and microbes for 25 years and voltages as per latest IEC standards.
- The cables used in module/ array wiring shall be TUV 2Pfg 1169/08.2007 or VDE EPV 01:2008-02 or UL4703/ EN 50618certified.
- Temp. Range 0°C to +90°C. Cable must be able to withstand this ambient temp range while carrying max current. Maximum and minimum withstand temperature of cable must be mentioned in engineering drawing for approval of purchaser with documentary proof.
- Fulfils IEC 60332-1 requirements. Accredited lab test report/Manufacturer's test report shall be attached.
- Conductor class IEC 60228 class 5. Accredited lab test report/Manufacturer's test report shall be attached. Only Copper conductor is to be used.
- All cables shall be Fire Retardant Low Smoke (FRLS) type. The cables shall be sized based on the following considerations:
 - Rated current of the equipment
 - The voltage drop in the cable, during motor starting condition, shall be limited to 10% and during running condition, shall be limited to 3% of the rated Voltage
 - Overload protection is to be provided. Design Overload capacity for 10 sec of 125% of continuous rating. The principle aim in this protection is to reduce the over voltage to a tolerable value before it reaches the PV or other subsystem components. The source of over voltage can be lightning or any other atmospheric disturbance.
 - Short circuit withstand capability De-rating factor for various conditions of installations shall be considered while selecting the cable size
 - Variation in ambient temperature for cables laid in air
 - Grouping of cable
 - Variation in ground temperature and soil resistivity for buried cables
- HT cable shall be designed based on the short circuit conditions and LT cable shall be sized based on the voltage drop.
- For breaker protected circuits minimum size will be determined by short circuit rating.
- Size of aluminium power cable shall in no case be less than 16 mm² and copper power cable shall not be less than 6 mm². Where there is requirement of cables

less than the above mentioned values, copper cable of appropriate size but not less than 4 mm² may be used.

- Minimum size of the control cable for CT circuit shall be 4 mm² and that for potential circuit shall be 2.5 mm².
- The cables shall be capable of satisfactory operation under a power supply system voltage variation of $\pm 10\%$ and frequency variation of $\pm 5\%$ and a combined frequency voltage variation of 10% (absolute sum). The cables shall have heat and moisture resistant properties.
- Conductor size of cables and wires shall be selected based on efficient design criteria. The wiring size shall be designed such that maximum voltage drop at full power from the PV Array to Inverter(s) should be less than 1.5%. From Inverter to AC Grid interfacing panel should be less than 2.5%.
- The continuous withstand temperature shall be 90°C and 70°C for XLPE and PVC cables respectively and the short circuit withstand temperature shall be 250°C and 160°C for XLPE and PVC cables respectively.
- All Power cables shall be XLPE, FRLSH.
- The Jointing Boxes shall comply in all aspects with the provision of the latest issue of relevant standards.
- The control cables shall be multi-core, colour coded, annealed, stranded high conductivity copper, single conductor, insulated with HR-PVC insulation, PVC sheathed, unarmored FRLS type conforming to IS 1554 (part I & II)/relevant IEC. The outer sheath is of specially formulated PVC compound.
- The instrumentation cables in addition to meeting the requirements of control cables shall be provided with electrostatic shielding by aluminium tape and screening by annealed tinned copper wire.
- Multipair, individual pair & overall screened, twisted pair instrumentation cable shall be provided for analog signals with stranded copper conductor.
- Multipair, overall screened & twisted pair instrumentation cable shall be provided for binary signals with stranded copper conductor.
- For connecting solar modules with solar inverter via array junction box, three winding transformer output with 33 kV Indoor Switchgear (33 kV) and 33 kV Indoor Switchgear (33 kV) with the 33 kV Switchyard (33 kV), cables of suitable size shall be provided.
- Cabling from Control Room to adjacent 33 kV Switchyard to be made through Cable Trench of suitable size as per relevant standard.

- Cable to be routed in standard manner through cable trays & cable marker to be placed for future identification.
- For physical protection of unarmoured cables (wherever used) suitable conduit to be provided wherever necessary. Armoured cable is to be used wherever required.
- The communication confined within the control/equipment room shall be through Shielded twisted Pair cable (STP) CAT 6.
- Single mode FO cable will be preferred, wherever FO cable is required.
- Dual redundant Optical Fiber Communication (OFC) cable shall be considered, wherever possible. Necessary ports/converters/hardware/software shall be provided.
- Separate system will have dedicated FO cable (as applicable).

5.9.15.5 TECHNICAL REQUIREMENTS OF CABLE RACKS AND TRAYS

Minimum technical requirements for cable racks and trays are mentioned below:

- The contractor shall fabricate and supply the mounting arrangement for the support and installation of all the cable trays on hot dip galvanized steel structure including channels, angles, rods etc at requisite spacing in the suspended cable trays, cable trenches. Supporting structures wherever necessary, shall be provided by the contractor.
- The contractor shall provide embedment/anchor fasteners for fixing the supporting structures.
- These supporting structures shall be fabricated from structural steel members (channels, angles and rods) of the required size.
- The vertical member of the support will be of ISRO12 threaded rod or ISMC100 channel. The horizontal member of the support will be of angle ISA 50X50X6. For the threaded rod support configuration the horizontal member shall be fixed by bolting whereas for channel configuration the horizontal member shall be fixed by welding to the channel.
- Trays shall be of ladder type. The trays shall be fabricated from Hot Rolled Carbon Mild Steel (conforming to IS 1079, Grade "O", of chemical composition (C, Si, Mn, S, Ph) sheet of proper thickness as per IS.
- Cable trays shall be fixed with support by hold-down clamps. The clamps shall be fabricated from MS sheet of appropriate thickness and Hot Dip Galvanized.
- The contractor shall supply various tray fittings and accessories like coupler plate with fasteners, horizontal tees, vertical and horizontal elbows, vertical and

horizontal adjustable connectors required for the mentioned trays. All accessories, fittings, elbows and tees shall be Hot Dip Galvanized. The nuts, bolts and washers shall be cadmium plated or electrolytically galvanized.

- Proper earthing of the trays and continuity between tray components must be ensured by the contractor.
- The contractor shall install the cable trays in accordance with relevant standards.
- The cable trays shall conform to bending & galvanization tests as per the relevant standards.

5.9.15.6 TECHNICAL REQUIREMENTS OF CABLE

- DC Cable from the individual floating solar plant to the respective Inverter cum control room to be laid on the underground cable for safe movement of vehicles through the embankment of the pond. Necessary suitable arrangement shall be finalized during detail engineering.
- 33kV incomer feeder cable for 33kV Floating Solar Control Room Switchgear to be laid down on the Pond embankment as per the specification shown in the tender drawing No.**SG-FSLP-DWG-E-002**.
- 33kV new outgoing feeder cable from 33kV Floating Solar Control Room Switchgear to be laid down as per the specification shown in the tender drawing No.**SG-FSLP-DWG-E-002** and approximate distance would be 1km.
- **However actual cable route through buried cable / cable trestle / cable trench shall be finalized after details engineering as per site condition not damaging any existing installation, cable, pipe lines etc. Bidder shall provide precast slab all along the cable route in case of Buried cable (refer NIT drawing). Bidder shall be responsible for all the damages of existing installation if any done during execution of the project, the same damages shall be rectified upto their existing standard by the bidder without any additional cost implication to WBPDCCL.**

5.9.15.7 APPROVAL

The Detailed Design Report Submitted by the contractor to WBPDCCL must contain but not limited to the following details of the Cables and conductor and the accessories for their installation:

- Detailed design and specification of all the items.
- All necessary drawings
- Calculations for choosing cable size

- Type test reports and necessary certificates etc.

Before dispatch, sample pieces of the cable shall be subjected to type, routine, acceptance and FRLS tests at the manufacturer's works as stipulated in IS 1554 (Part I)/IEC in the presence of owner or his representative. Routine tests and acceptance tests as per relevant standards shall be carried out on each type of cable in presence of the owner or his representative.

Before commissioning of complete system all cabling system shall be checked as per cable schedule and complete report shall be prepared by Contractor and shall be submitted.

Prior to the delivery of the product, the contractor shall submit but not limited to the following documents:

- Guarantees
- Cable routing and layout drawings
- Detailed procedure adopted for the earthing of the trays
- Type test certificates for cable trays etc.

The contractor can deliver the product to the site only after receipt of such approval against their prayer in writing from WBPDCCL.

5.9.16 DATA LOGGER:

- a) Web enable data logging system may be an integral part of the inverter or a separate unit.
- b) The data logger should have required transducer to monitor and record the required system parameters.
- c) The data Logger, where the weather monitoring station shall be connected, shall keep record of **Global Solar Radiation, PV module temperature and ambient temperature and associated electrical parameters** at different stages to study performance of system as well as to study status of the system at a particular instant.
- d) The Data logger shall continuously send data to the Web server.
- e) If the Power Plants shall installed in distributed manner and at more than two buildings then necessary arrangement shall have to be provided so that compiled data shall be uploaded to the Website against each site.
- f) The data logger shall have reliable data storage capacity (of minimum four months) to record all sorts of data simultaneously round the clock.

- g) **SPD (surge protection device) Type II suitable for communication network, as much number at suitable locations are required must be provided with the system**

5.9.17 WEATHER MONITORING STATION

- i) Weather Monitoring Station comprised of the following:
- a) **Solar Irradiance:** An integrating Pyranometer (Class II or better) shall be provided, with the sensor mounted in the plane of the array. Readout shall be integrated with data logging, system.
 - b) **Wind Speed:** An integrated wind speed measurement unit shall be provided.
 - c) **PV module temperature sensor, ambient temperature:** Temperature probes for recording the PV Module temperature and ambient temperature shall be provided.
- ii) The components of the Weather Monitoring Station shall be matched with the Data Logger system and Web based Monitoring system and connected with the Data logger.
- iii) The data from the Weather Monitoring station shall be sent to the Web server through Data logger and shall be downloaded from the remote server from any where

5.9.18 WEB BASED ON LINE REMOTE MONITORING SYSTEM:

- a) Web based Remote Monitoring system must be compatible with data logger (s).
- b) The system(s) shall be provided with suitable modem and required SIM card for wireless communication or connection from internet service provider (Wire system)
- c) The Modem shall be interconnected with all the locations of installation of PV power Plants at different buildings of the site through wires / wireless system/ or any other technology so that Beneficiary wise composite and for individual power plant data shall be observed and downloaded from the remote server through web.
- d) The contractor shall provide the website address and password to the purchaser for asses the data from the remote server.
- e) If there is communication signal at the site is weak, necessary antenna or any other suitable instrument as may be required must be provided with the communication system.

- f) The Data logger shall continuously send data to the Web server.
- g) The other required accessories, hardware and compatible software shall have to be provided as an integrated part of the system to monitor the real time data (maximum 20 minutes delay) through web server.
- h) The system can be monitored from anywhere through internet without installing any special application software. The server shall be arranged by the contractor.
- i) The rental and other costs of the SIM cards, IP address, Server charge (storage, access charge and other charges if any), Rental charge of data communication for remote monitoring system for a period of five (05) years shall be within the contract value.
- j) If more than one data logger and web based monitoring system shall with different PV Power Plant installed at different location within a same campus, consolidated data and graphical representation of the parameters including the weather monitoring report shall be obtained through web.
- k) The Web based monitoring system should have the provision of graphical representation of the data shall include but not limited to the following:

Sl. No.	Operating Parameter	Desired specification
1.0	Input data	PV Power PV Energy
2.0	Meteorological data	Global solar Radiation Module Temperature Ambient Temperature Wind Speed
3.0	Output data	
3.1	Inverter	Export Power Export energy

- l) All data shall be recorded chronologically date wise. The data file should be MS Excel/XML/or any readable form compatible and should have the facility of easy downloads from the website and onsite.

5.9.19 EXPORT IMPORT ENERGY METER:

3 phase whole current Export Import Energy Meter. The Meter to be supplied must be tested. The export Import Energy meter shall be installed at the within the **Grid Interfacing Panel**. This Export- Import meter shall be

installed to measure the total energy to be imported and exported from the PV power Plant.

5.9.20 ILLUMINATION SYSTEM

5.9.20.1 SCOPE

The scope of work under this specification covers design, manufacture, assembly, shop testing, delivery, site erection, testing & commissioning of Illumination system comprising of main Illumination switchboards, distribution boards, sub distribution boards, switchboards, lighting fixtures, convenience and power outlets, conduits & fittings, cabling, outdoor lighting including mounting structures & poles, lighting for control rooms, security cabin, watch tower, access road, across the embankment (maximum 15 m between two adjacent lamps).

The illumination system shall be designed as per relevant Indian Standard / Guideline for different location of the plant. The lighting arrangement should be LED Based.

The scope of supply shall also include necessary spares required for normal operation & maintenance of illumination equipment for a period of 5 (five) years & special tools & plants required for erection & maintenance. Corresponding parts of all the equipments & spares shall be of the same material & dimensions, workmanship & finish and shall be interchangeable.

5.9.20.2 STANDARDS

The material, equipment and its installation under the scope shall comply with all applicable provisions of the latest Indian standards and codes of practice. Some of the relevant standards are given below:

Sl. No.	Standards	Description
1	IS: 3646	Code of practice for interior Illumination (Part I, II, III)
2	IS: 6665	Code of Practice for Industrial Lighting
3	IS: 732	Code of Practice for Electrical wiring installations
4	IS: 9537	Conduits for Electric installations
5	IS: 2418	Tubular fluorescent lamps for general lighting service
6	EN 61347-2-13	Particular requirements for D.C. or A.C. supplied electronic control gear for LED modules
7	EN 62384	D.C. or A.C. supplied electronic control gear for LED modules
8	EN 61000-3-2	Electromagnetic compatibility (EMC). Limits for harmonic current emissions (Equipment input current < 16 A per phase)
9	EN 61000-3-3	Limitation of voltage fluctuation and flicker in low

		voltage supply systems for equipment with rated current ≤ 16 A
--	--	---

The installation shall generally be carried out in conformity with the requirements of Indian Electricity Act 1910 (latest Amendment) & Indian Electricity Rules.

5.9.20.3 REQUIREMENT

The lighting system for outdoor and indoor areas of Solar Power Plant shall be designed in such a way that uniform illumination is achieved.

In outdoor yard equipment / bus bar areas and the peripheral wall are to be illuminated and luminaires shall be aimed for clear view.

5.9.20.4 LIGHTING LEVELS

The complete switchyard shall be lightened with an average illumination level of 100 lux.

Lighting in other areas such as control room, office rooms and battery room & other areas (i.e. street light) shall be such that the average LUX level to be maintained shall be as under:

SI No.	Area	LUX
1	Control Room and equipment rooms	500
2	Office	300
3	Battery & other rooms	150
4	Other areas including embankment	20
5	H – pole and metering point	20

5.9.20.5 EMERGENCY LIGHT POINTS

Light points using LED lamps at 220 V shall also be provided as per requirement of the following area:

- All emergency light shall be from 220 V DC Battery/ Local UPS.
- Control room and equipment room, Battery room, UPS Room/ Office, Corridor, Local Inver cum Control Room or any other place where light is required for clear vision.
- These lights shall operate on AC/DC changeover supply from the DC distribution Board. Separate wiring and distribution board shall be provided from these lights.
- Battery room shall be corrosion proof type lamp and fixtures.

5.9.20.6 APPROVAL

The Detailed Design Report submitted by the contractor to WBPDCCL must contain but not limited to the following details of the illumination system:

- Detailed scheme and specification
- Illumination calculations for arriving at the number of lighting fixtures for different areas & rooms considering the required lux level as per relevant IS Code.
- Necessary drawings etc.

Drawings and scheme submitted by the contractor will be subjected to approval of the owner.

The contractor can deliver the product to the site only after receipt of such approval against their prayer in writing from WBPDCCL.

C. MISCELLANEOUS WORKS:

5.9.21 FIRE PROTECTION SYSTEM

5.9.21.1 SCOPE

The scope of work under this specification covers design, engineering, quality assurance, manufacture, shop testing, transport, transit insurance, delivery to site, storage at site, site erection, testing & commissioning of fire protection system (fire extinguisher (type shall be selected as per requirement), fire buckets, fire alarms at all control rooms etc.) complete with all accessories.

The scope of supply shall also include necessary spares required for normal operation & maintenance of illumination equipment for a period of 5 (five) years & special tools & plants required for erection & maintenance. Corresponding parts of all the equipments & spares shall be of the same material & dimensions, workmanship & finish and shall be interchangeable.

5.9.21.2 STANDARDS

All equipment covered under this section will conform to the latest edition of following Indian Standards:

Sl. No.	Standards	Description
1	IS: 3034	Code of Practice for Fire Safety of Industrial buildings: Electrical generating and distributing stations.
2	IS: 3844	Code of Practice for installation of internal fire hydrants in multi-storied buildings
3	IS: 1646	Code of Practice for fire safety of buildings (General) Electrical Installations

4	IS: 2878	Specification for fire Extinguishers – Carbon dioxide type
5	IS: 2171	Specification for fire Extinguishers – Dry Powder type
6	IS: 933	Specification for fire Extinguishers – Foam type
7	IS: 2175	Specification for heat sensitive fire detectors for use in automatic electrical fire alarm system
8	IS: 2189	Code of Practice for installation of automatic fire alarm system using heat sensitive type fire detectors

5.9.21.3 APPROVAL

The Detailed Design Report submitted by the contractor to WBPDCCL must contain but not limited to the following details of the fire protection system:

- Detailed scheme and technical specification
- Placing and type of fire extinguisher with justification
- Necessary drawings related to the system etc.

Drawings and scheme submitted by the contractor will be subjected to approval of the owner.

The contractor can deliver the product to the site only after receiving such approval against their prayer in writing from WBPDCCL.

5.9.22 VENTILATION SYSTEM

5.9.22.1 SCOPE

The scope of work under this specification covers design, manufacture, shop testing, supply, transportation, delivery, storage at site, erection, testing and commissioning of ventilation system complete with all accessories at each Inverter cum control rooms, store room etc.

The Scope shall include supply of all blower fans, GS ducting, air plenum, exhaust fans air dampers etc as required to make the ventilation system complete in all respects for satisfactory operation.

The scope of supply shall also include necessary spares required for normal operation & maintenance of ventilating equipments for a period of 5 (five) years and special tools & plants required for erection & maintenance.

Corresponding parts of all the equipments & spares shall be of the same material & dimensions, workmanship & finish and shall be interchangeable. All the material & workmanship shall be of suitable commercial quality as have proven successful in their respective uses in similar services & under similar condition.

5.9.22.2 STANDARDS

The ventilating equipment shall comply with the requirement of the latest edition of relevant Indian standards or equivalent British Standards. Some of the relevant standards are given below:

Sl. No.	Standards	Description
1	IS : 3103	Code of Practice for industrial ventilation
2	IS : 2312	Specifications for propeller type A.C. Ventilating fans.
3	IS: 4894	Centrifugal fans

5.9.22.3 APPROVAL

The Detailed Design Report submitted by the contractor to WBPDC must contain but not limited to the following details of the fire protection system:

- Detailed scheme and technical specification
- Calculations showing air requirements at various locations
- Necessary drawings etc.

The successful bidder required to produce all necessary test certificates and approvals of the product as per relevant standard with the Detailed Design Report.

Drawings and scheme submitted by the contractor will be subjected to approval of the owner. The contractor can deliver the product to the site only after receiving such approval against their prayer in writing from WBPDC.

5.9.23 AIR CONDITIONING SYSTEM

5.9.23.1 SCOPE

The scope of work under this specification covers design, manufacture, testing, supply, transportation, transit insurance, delivery, storage at site, erection, testing and commissioning of Air conditioning system with control and accessories at the operator's work station, SCADA room and UPS room with 100% redundancy at main control building.

5.9.23.2 STANDARDS

Equipment shall conform to the latest Indian standards or equivalent British Standards.

Sl. No.	Standards	Description
1	IS: 659	Safety code for Air conditioning
2	IS: 660	Safety code for Mechanical Refrigeration
3	IS: 655	Metal Air ducts

5.9.23.3 APPROVAL

The successful bidder required to produce all necessary test certificates and approvals of the product as per relevant standard with the Detailed Design Report.

The Detailed Design Report submitted by the contractor to WBPDCCL must contain but not limited to the following details of the Air Conditioning system:

- Detailed scheme and technical specification
- Necessary drawings etc.

Drawings and scheme submitted by the contractor will be subjected to approval of the owner. The contractor can deliver the product to the site only after receipt of such approval against their prayer in writing from WBPDCCL.

5.9.24 DRINKING WATER

5.9.24.1 SCOPE

The scope of supply under this section shall cover the design, manufacture, shop testing, supply, transportation, delivery, storage at site, erection, testing and commissioning of drinking water system with water purifier unit and other related plumbing arrangement and accessories etc. for drinking water supply for the personnel at the Control Building. A drinking water point will be provided (within 500m from control building) and the contractor to draw pipelines to the requisite location.

5.9.24.2 STANDARDS

The whole system shall conform to the latest edition of relevant Indian Standard.

5.9.24.3 APPROVAL

The Detailed Design Report submitted by the contractor to WBPDCCL must contain but not limited to the following details of the water purification unit:

- Detailed Technical specification
- Necessary drawings etc.

Specification submitted by the contractor will be subjected to approval of the owner. The contractor can deliver the product to the site only after receiving such approval against their prayer in writing from WBPDCCL.

5.9.25 SIGNAGE:

5.9.25.1 Project information Signage:

The Signage will be made up of metallic base of minimum size 3'x 2'. The Signage provide with detail of the project as approved by WBPDCCL. The font size on the

signage has to be big enough so that everyone can read it easily. The Signage will be fixed **up two (02)** prominent place of the project area.

5.9.25.2 SCHEMATIC DIAGRAM SIGNAGE:

Schematic Diagram of Installation must be provided on a display board of minimum size 3’x 2’ made up of metallic base. The schematic diagram must be fixed up at any prominent place of installation.

5.9.25.3 SAFETY SIGNAGE:

Safety Signage must be provided indicating the level and type of voltage and symbols as per IE Rule at different position as may be required. In the safety signage Voltage level and type of voltage must be mentioned

Each set of Safety Signage contain minimum 06 (six) nos. safety signage:

Location	Quantity
PV Array Field	Minimum 2 nos.
On PV Array JB	01 No. (Sticker)
Near Inverters	01 No
On Inverter Interfacing LT Panel	01 no. (Sticker)
On Grid interfacing Panel	01 No (Sticker)

5.9.26 FIRE BUCKETS AND HOLDING STANDS

Each set of Fire Buckets and Fire Bucket Holding Stand shall have four (04) Fire Buckets and one (01) Double Tier Fire Bucket Holding Stand with an arrangement of holding of minimum four (04) Fire Buckets. The Fire Bucket Stand shall be installed at the suitable location.

The minimum technical specification is a follows:

BIS Specification	IS 2546 (with latest amendments)
Fire Bucket Capacity	10 liters
Fire Bucket Body Material	Mild Steel Sheet

FIRE EXTINGUISHERS

Minimum three (3) nos DCP type dry power portable fire extinguishers of minimum capacity 5 kg shall be provided. Standard of Fire Extinguisher BIS 2171 (with latest amendments).

5.9.27 KIOSK

The Solar Inverter, Inverter Interfacing Panel shall be installed in suitable

locations in Metallic Kiosks. The kiosks must be of a suitable design, painted for avoiding rust, covered with a door and locking arrangement with good air circulation. The Kiosks must have security arrangement against theft, manhandling etc. Minimum clearance of the lower edge of the equipments from floor should be 1.0 m. There must be a suitable clearance from the front door of the Kiosk with any of the equipments / panel within the Kiosk.

Necessary civil work as required to construct / fixing the Kiosks (s) shall be done by the contractor. If any civil construction is required for installing the whole arrangement, as and where required, it will be within the cost of contract value.

5.9.28 TOOLS, TACKLES AND SPARES

The Installer shall keep ready stock of tools, tackles and essential spares that will be needed for the day-to-day maintenance of the solar PV system. This shall include but not be limited to the following:

- i. Screw driver suitable for the junction boxes and combiner boxes.
- ii. Screw driver and / or Allen key suitable for the connectors, power distribution blocks, Circuit breaker terminals and surge arrestor terminals.
- iii. Spanners / box spanners suitable for the removal of solar PV modules from the solar PV module support structure.
- iv. Solar panel mounting clamps.
- v. Cleaning tools for the cleaning of the solar PV modules.
- vi. Spare fuses.
- vii. Panel efficiency measurement tools
- viii. One 20HP flattered Boat

5.9.29 OTHER CONDITIONS

The work includes necessary excavation, concreting, flooring, platform, necessary finishing, painting, back filling, shoring & shuttering, cable laying, location of installation of different component of PV Power Plant etc. if any , required for completion of the project in all respect shall be as per direction of Engineer-in-Charge.

5.9.30 SPECIFICATION OF 36kV OUT DOOR VCB

5.9.30.5.1 SCOPE

This specification covers design, manufacture, assembly, testing at manufacturer's works of Vacuum Circuit Breaker of 36 KV class (Outdoor) as detailed in the enclosed Schedule, complete with accessories required for efficient and trouble free operations.

The circuit breakers offered shall be as per specific technical parameters and suitable for outdoor installation.

The circuit breakers are required complete with structures, operating mechanism, all associated accessories and auxiliaries.

5.9.30.5.2 STANDARDS

The equipment to be furnished under this specification, shall unless and otherwise stated, be designed constructed and tested in accordance with the latest revisions of Indian Standards as follows :

IS-13118 - General requirements for circuit breakers for voltages above 1000 V

IS-9135 - Guide for testing of Circuit Breaker

IS-2099 - Bushings

IEC - 62271-100

IEC - 60694

IEC - 56

5.9.30.5.3 GENERAL INFORMATION

The circuit breakers of 36 KV Class shall be outdoor type vacuum circuit breaker

The equipment covered by this specification shall be complete in all respects. Any material or accessory which may not have been specifically mentioned but which is usual or necessary for satisfactory and trouble-free operation shall be within the scope of supply without any extra charge to the WBPDCCL.

Two nos. trip coils shall be provided for circuit breaker for 36 KV (each pole operated individually). The support structure of Circuit Breaker as well as control cabinet shall be hot dip galvanized. All other parts shall be painted as per Specification.

5.9.30.5.4 DESIGN CRITERIA

- a) The Circuit Breakers shall be used in neutral solidly ground system with symmetrical fault level of 25 KA for 3 sec at system voltage of 33KV. Earthing of 33KV system for 220/33KV transformer is under bidder scope of design as per system requirement.
- b) All controls shall be suitable for 85% to 110% for closing and 70% to 110% for tripping of 220 Volts ($\pm 10\%$) D.C supply voltage for 33 KV & above. The A.C. supply shall be available at 400 V ($\pm 10\%$), 50 c/s, 3 phase 4 wire system or 230 V ($\pm 10\%$), 50 c/s, 1-ph 2-wire system.

- c) Radio interference voltage shall not exceed 1000 micro volt when the equipment will be operated at maximum service voltage for circuit breakers rated 132KV and above.
- d) The maximum temperature attained by any part of the equipment at specified rating should not exceed the permissible limits as stipulated in relevant standards. Equipment shall be designed taking 50°C as maximum ambient temperature.
- e) The minimum safe clearance of all live parts of the equipment shall be as per relevant standards and electricity rules. Clearance of Phase to Phase low level pipe bus are as follows :
- f) 33 KV : Phase to Phase (mm) 1500
- g) In case of gang operated breaker of 36 KV class, the minimum clearance between poles shall not be less than 430 mm respectively and shall withstand the impulse/power frequency level as specified in our technical parameters.
- h) Provision of electrical interlocks for safe and satisfactory operation of the Breaker shall be furnished. The interlocking device shall be of proven quality.
- i) The breaker shall be able to function even under conditions of phase opposition that may arise due to faulty synchronisation or otherwise as per relevant IS standard or IEC Standard.
- j) Breaker shall be capable of interrupting line/cable charging current as per IEC without any restriking and without use of opening resistors.
- k) The breaker shall be capable of interrupting rated breaking current with recovery voltage equal to maximum line service voltage and at all indicative power factor of the circuit equal to or exceeding 0.15.
- l) Breaker shall be capable of clearing short line fault without excessive rise of restriking voltage.
- m) The breaker shall be suitable for interrupting low inductive currents (0.5A to 10A) as well as capacitance, without undue over voltage.
- n) The Bidder may indicate in his offer the methods adopted for limiting over voltages.
- o) The circuit breaker of 36KV rating shall be capable to withstand power frequency over voltage as per value specified in IEC 62271-100 or relevant IS.
- p) Operating duty of all circuit breakers from voltage range 36 KV shall be as follows :
O-0.3 sec-CO-3.0 min-CO
- q) The Circuit Breaker shall be re-strike free as per IEC under all duty conditions and shall be capable of performing their duties without opening resistors.
- r) The Circuit Breaker shall meet the duty requirement of any type of fault or fault location also for switching when used on 33KV ungrounded system as well as non-effectively grounded but with NGR (if applicable) for 220/33KV substation and perform make and break operation as per duty cycles specified in above clause.
- s) The breaker shall be capable of interrupting steady state and transient magnetizing current corresponding of power transformers.

- t) If specifically mentioned in BOQ, Circuit breaker shall be provided with Control Switching device as per relevant standard.

5.9.30.5.5 CONSTRUCTIONS

Each 36KV VCB shall comprise of three identical poles linked together electro-mechanically for simultaneous operation of pole units.

Operation counter should be provided to monitor the no. of operations.

MAIN CONTACTS AND ARC QUENCHING CHAMBER:

The tips of the main contacts shall be of suitable design and adequately silver plated to withstand arcing.

5.9.30.5.5.1 OPERATING MECHANISM:

- i. The operating mechanism shall be electrically controlled spring / spring operated for 36 KV class breakers. The mechanism shall have anti-pumping and trip free circuitry. The anti-pumping arrangement shall be initiated through Normally open (NO) type auxiliary contact of circuit breaker and shall be of 'self-hold' type. Type of such mechanism shall be mentioned. Local arrangement for operating the breakers both electrically and mechanically shall be provided in addition to remote electrical operation.
- ii. There shall be mechanical ON/OFF indicator and number of operation counter for each pole of breaker in case of single pole operation and one mechanical ON/OFF indicator and provision for operation counter for 3 pole gang operated breaker.
- iii. All three poles of circuit breaker shall operate simultaneously. Pole discrepancy feature shall be provided to trip the breaker if all the poles do not close/open simultaneously in case of single pole operation. For mechanically gang operated breaker pole discrepancy feature need not be provided.
- iv. The operating mechanism box shall be fixed at a suitable man working height from ground level. View glass shall be provided on hinged door at the front. Hinged door shall be properly earthed with main body through copper flexible braided conductor. In case operating mechanism box shall not be placed at a suitable man working height, platform is to be arranged /supplied for each such breaker by the contractor. Suitable arrangement at site has to be made near each breaker to climb on the platform and work comfortably.
- v. Suitable arrangement shall have to be made for easy accessibility to the operating mechanism box. All necessary arrangements are within the scope of bidder.
- vi. Indication for spring charged condition shall be provided for breaker with spring charging mechanism. The spring charging mechanism shall be motor operated. After failure of power supply to the motor, one CO operation shall be possible with the energy stored in the operating mechanism.

5.9.30.5.5.2 SPRING OPERATED MECHANISM:

- i. Spring operating mechanism shall be complete with motor. Opening spring and closing springs with limit switch for automatic charging and other necessary accessories to make the mechanism a complete operating unit shall also to be provided.
- ii. As long as power is available to the motor, a continuous sequence of closing and opening operations shall be possible. The motor shall have adequate thermal rating for this duty.
- iii. Breaker operation shall be independent of the motor, which shall be used solely for compressing the closing spring. Facility for manual charging of the closing spring shall also be provided.
- iv. Closing action of circuit breaker shall compress the opening spring ready for tripping.
- v. When closing springs are discharged after closing a breaker, closing spring, shall be automatically charged for the next operation and an indication of this shall be provided in the local and remote control cabinet.
- vi. Provisions shall be kept to prevent a closing operation of the breaker when spring is in partially charged condition. Mechanical interlocks shall be provided in the operating mechanism to prevent discharging of closing springs when the breaker is already in closed position.
- vii. The spring operating mechanism shall have adequate energy stored in the operating spring to close and latch the circuit breaker against the rated making current and also to provide the required energy for the tripping mechanism in case of tripping energy is derived from the operating mechanism.

5.9.30.5.5.3 COMMON CONTROL CUBICLE / MARSHALLING BOX:

A free standing outdoor type weather proof common marshalling box/cubicle shall be provided to house different accessories except those which must be located in the pole unit operating box. Rubberized gaskets of durable quality shall be provided to make it water proof, dust and vermin proof. Degree of protection shall be IP-55 as per IS:13947

This outdoor cubicle shall be of 3.00 mm thick steel sheet and shall have hinged doors at front and rear for access to the mechanism. Doors should be of proper design & adequate MS sheet thickness and providing adequate stiffener, for smooth opening and closing. There shall be arrangement for padlocking, individual door panel should be connected with the main panel body by flexible braided copper conductor for earthing purpose at two points.

A removable gland-plate, 3.00 mm thick shall be provided at the bottom of the cubicle for cable entry. Gland sizes shall be suitable for entry of adequate number of multicore cables separately for AC & DC as per approved scheme.

Terminal blocks for AC & DC shall be kept isolated. Terminals shall be suitable for at least three nos. 2.5 mm sq. copper leads. All control wiring shall be of 1100 Volt grade 2.5 mm sq. copper PVC insulated cables.

Thermostat controlled heaters shall be provided to prevent condensation within the cubicle /switchgear. Cubicle illumination lamps with switch shall be provided.

A 230 Volt combined 5A/15A three pin socket with neutral earthing and a control switch shall be provided inside the box.

Suitable arrangement i.e. platform shall be provided with support structure for easy access to the operating mechanism box for personnel of average height. View glass shall be provided on hinged door for reading pressure gauge, ON-OFF indication mounted inside the cubicle.

Spring charged mechanism shall be placed within the operating mechanism box / marshalling box and contacts shall be provided for spring charged indication.

All controls, alarms, indications and interlocking devices furnished with breaker shall be wired up to the terminal block in common operating box / marshalling box. Not more than two wires shall be connected to one terminal. All spare contacts available in the pressure switches etc shall be wired upto terminal block.

All wires shall be identified at both ends with ferrule marking in accordance with approved wiring diagram.

The terminal blocks shall be of 1100 V grade and have continuous rating to carry the maximum expected currents on the terminals. Insulating barriers shall be provided between the terminals. The terminal block shall have locking arrangement to prevent its escape from the rails. The terminal blocks to be provided shall be fully enclosed with removable covers and made of moulded, non-inflammable plastic material. All terminals shall be clearly marked with identification numbers or letters to facilitate connection to external wiring. At least 20% spare terminals shall be provided.

5.9.30.5.5.4 INSULATORS:

The porcelain to be used in bushing shall be homogeneous, free from laminations, cavities and other flaws which may impair its mechanical and/or dielectric strength and shall be glossy, tough and impervious to moisture.

The bushings shall have adequate mechanical strength and rigidity for conditions under which they will be used.

Bushing insulation shall be coordinated with that of Circuit Breaker. The puncture strength of the bushings shall be greater than the dry flashover value.

When operating at rated voltage and under operation in heavily polluted area, there shall not be any electrical discharge between bushing terminal and earth. No radio disturbance shall be caused by the bushings when operating up to the maximum system voltage. It shall also be free from corona.

All iron parts shall be hot dip galvanised.

All bushings of identical rating shall be interchangeable. Each bushing shall be provided with :

Terminal connector suitable for connection to either 'ACSR' Conductor / Aluminium pipe shall be provided as per requirement. Particulars of 'ACSR' Conductor / Aluminium pipe to be connected with terminal of different voltage classes are specified under Specific Technical Parameters.

All terminal connectors required for circuit breaker shall be guided by technical specification for Clamps and Connectors. Relevant drawings are to be submitted for approval before supply.

5.9.30.5.5.5 AUXILIARY CONTACTS:

The breaker shall be provided with 6 NO + 6 NC for 36KV CBs as spare auxiliary / multiplied contacts in addition to the auxiliary contacts required for breaker's own operational requirements.

The auxiliary / multiplied contacts shall have continuous current rating of at least 10 A. The breaking capacity shall be adequate for the circuits controlled, and at least 2 A at 220 V DC for inductive circuit with time constant of minimum 20 ms.

All auxiliary / multiplied contacts shall be wired up to terminal block in the control cubicle.

Auxiliary/multiplied contacts shall be suitably protected against arcing. Insulating materials of the base of the contacts shall be moulded plastic or other non-breaking, non-inflammable insulating material.

5.9.30.5.5.6 GROUNDING

Circuit Breaker shall be provided with two grounding terminals suitable for connecting G.S. Flat of 50×10mm (min) for all voltage classes per pole each with tapped holes. Necessary stainless steel bolts and washers, spring washers are to be supplied for connection to grounding strip, size of which shall be as per requirement.

5.9.30.5.5.7 PAINTING

All steel surfaces shall be cleaned by sand blasting or chemical process as required to produce a smooth surface, free of scale, grease and rust. Steel surface in contact with insulating oil shall be painted with heat resistant oil insoluble insulating varnish. External surfaces shall be given a coat of high quality red or yellow chromate primer and finished with gray colour (IS:631) with two coats of synthetic enamel paints. Paints shall be carefully selected to withstand tropical heat, rain etc. The paint shall not scale off or crinkle or be removed by abrasion due to normal handling. Sufficient quantity of touch up paint shall be furnished by application at site.

5.9.30.5.5.8 EQUIPMENT FOUNDATION AND SUPPORT STRUCTURE

Refer Technical Specification of Civil.

5.9.30.5.5.9 36 KV VACUUM CIRCUIT BREAKER:

Each vacuum Circuit breaker shall comprise of three identical poles linked together electrically and mechanically for synchronous operation.

5.9.30.5.5.10 VACUUM INTERRUPTER AND CONSTRUCTIONAL FEATURE

The vacuum interrupter, consisting of fixed contact and moving contact, shall be interchangeable among the same type interrupter. Short circuit capacity of vacuum bottle should be 25 KA and design life should be 100 nos. operation at rated short circuit level.

Constructional features of the vacuum chamber along with its functional arrangements are to be shown in a drawing submitted along with tender documents.

The gap between contacts of the Circuit Breaker inside interrupter should be capable of withstanding 1.5 time voltage to neutral at one atmospheric pressure at normal ambient condition within Breaker in the event of vacuum pressure drop due to leakage.

The circuit breakers and their components shall be capable of withstanding the mechanical forces and thermal stresses of the short circuit current of the system without any damage or deterioration of material.

The circuit breakers shall have motor wound spring charged trip free mechanism with anti-pumping feature, and shunt trip. In addition, facility for manual charging of spring, shall be provided.

Each breaker shall be provided with manual close & open facility, mechanical ON-OFF indication, an operation counter and mechanism charge/discharge indicator.

For motor wound mechanism, spring charging shall take place automatically after each breaker closing operation. One open-close-open operation of the circuit breaker shall be possible after failure of power supply to the motor. A visual mechanical indicating device will also be provided to show the position of the spring.

36KV VCB, with duty cycle O- .3sec CO-3min CO, Class- C2-M2 as per relevant IEC, 1250A, 25KA for 3 sec, 70kvrms/170kvp, 3-Phase, Outdoor VCB with 2TC & 1CC, 220V DC.

The offered VCB shall be well proven in NTPC. Offered bottle shall be identical with Type tested one. Brochures/leaflet on technical data sheet for vacuum bottle shall also be submitted.

The VCB shall be complete with structure, operating mechanism in a common Control cubicle with degree of protection IPW-55, situated at accessible man height, along with all associated accessories and auxiliaries and terminal connector as per specification and approved drawing during detailed engineering. The supply shall include 2 Set of complete bottle. (1 set comprises of one complete VCB i.e. inclusive of 3 poles).

The bidder shall submit detailed as well as complete Type test reports as stipulated in relevant IS and IEC with complete identification, date and

serial no. of circuit breakers of identical design with identical bottle from CPRI, NABL accredited/a Government recognized test house or laboratory during detailed engineering.

Make & Type of VCB & Vacuum Interrupter with detailed literature shall be furnished along with bid.

5.9.30.5.6 TEST

A. Routine Test

During manufacture and on completion, all equipment, clamps, connectors and accessories shall be subjected to the Routine Tests as laid down in latest revision of IEC/IS.

In addition to above tests specified by IEC/IS, the following tests also have to be carried out for specific equipments :

The speed curves for 220 KV circuit breaker shall with the help of a suitable operation analyser to determine the breaker contact movement during opening, closing, auto-reclosing and trip-free operation under normal as well as limiting operating conditions (Control Voltage etc.)

B. Type Test

Type tests on circuit breaker, disconnecting switch, CT & LA shall carried out as stipulated in relevant IEC/Indian Standards.

Following additional type tests are to be conducted for 220 KV circuit breaker:

- i) Out of phase closing test as per IEC-267 & IEC-62271-100.
- ii) Line charging breaking current test. The breaker shall be able to interrupt the line charging current with a test voltage of 1.4p.u. instead of 1.2 p.u. as per IEC-62271-10

5.9.30.5.7 MANDATORY SPARE PARTS

Sl No.	33KV Breaker	Spare quantity
(i)	Closing Coil with resistor	3 Nos.
(ii)	Tripping Coil with resistor	6 Nos.
(iii)	Braker Auxiliary Contact	2Sets
(iv)	Set of O-ring	3Sets

5.9.30.5.8 AVAILABILITY OF SPARE

The successful bidder shall submit manufacturer's undertaking during submission of drawings of Circuit Breaker that the spares for the supplied breaker (for all voltage classes and all makers) shall be available for at least ten years from the date of placement of LOA. All the participating bidders shall have to confirm in writing submission that the above mentioned undertaking from the manufacturer shall be submitted in case they receive order.

5.9.30.5.9 FURNISHING DETAIL GTP FOR 36 KV VACUUM CIRCUIT BREAKERS) during approval

Sl. No.	Description	Particulars
1.	Conforming Standard	:
2.	Service (Outdoor/Indoor)	:
3.	Frequency	:
4.	Rated operating duty	:
5.	Rated (TRV) for terminal fault	:
6.	Short time Fault breaking capacity MVA	:
7.	Line charging current breaking capacity	:
	a) line charging current AMP	:
	b) Corresponding Over voltage (KV)	:
	c) Whether Switching Resistor is provided	:
	i) Value of Resistor	:
	ii) Time of insertion	:
	iii) Thermal Rating of Resistor	:
8.	Maximum shunt capacitor bank switching/breaking capacity in MVA and the over voltage factor.	:
9.	Maximum over voltage in Kilovolts on switching OFF Transformer on low load.	:
10.	i) Breaks per pole (No)	:
	ii) Length of each break per pole (mm)	:
	iii) Length of moving contact travel mm	:
	iv) Rate of contact travel (m/sec)	:
11.	Make time (ms)	:
12.	Minimum reclosing time at rated interrupting Capacity from the instant of the trip coil energisation (ms)	:
13.	Minimum dead time for 1 phase & 3 phase reclosing With corresponding limits of adjustment of dead time, If any.	:
14.	Maximum radio interference voltage between 0.5 MHz to 2 MHz with Voltage of 110% of rated rms voltage between phase & ground (Micro-Volt)	:
15.	Details of manually/motor operated spring charging mechanism.	:
16.	i)Voltage and Power requirement for a) closing coil b) Tripping coil ii) No of Tripping Coil	:
17	Vacuum Bottle	:
17 a)	Make, Country, Type & Designation of Vacuum Bottle used in VCB.	:
17 b)	Number of operation at full short ckt level,	:
17 c)	no. of operation at rated current and other details	:
17 d)	Whether Literature & Catalogue of offered Vacuum Bottle containing the specific particulars enclosed?	:
18.	Weight of Vacuum Circuit Breaker	:
19.	No. of auxiliary contacts (Spring Charging LS) number of NO and NC shall be mentioned. No. of auxiliary spare contacts	:
20.	Power frequency withstand capability of breaker	:

Sl. No.	Description	Particulars
	in open condition at :	
	i) Atmospheric Pressure of Air/Zero Vacuum Pressure	:
21.	Actual opening time (from Trip Coil energisation to contact separation) (ms)	:
22.	Allowable time limit between breaker per pole (for multibreak type) and between poles (ms)	:
23.	Actual closing time (from Closing Coil energisation to contact touching (ms)	:
24.	Whether type tests report submitted in line with specification for similar breaker with offered vacuum Interrupter?	:
25.	Whether a) Dimensional GA Drawing Cross Sectional b) Drawing of interrupting Chamber and c) scheme diagram are furnished.	: a) b) c)
26.	Whether brochure/ leaflet on Technical data for Vacuum bottle enclosed?	

NOTE:

Any item/equipment not mentioned in the Technical Specification, but required for successful completion of the project shall be deemed to be a part of the scope of the work and the same shall be included by the bidder in their Billing Break Up (BBU).

D. APPROVED VENDOR LIST FOR BOIs:

Equipment	List of Vendor for various BOIs
SOLAR PANELS	Any Solar PV Manufacturer in India having MNRE Certification
INVERTERS	ABB/ HITACHI/SMA/ DELTA
TRANSFORMER	SUDHIR/VOLTAMP/BHEL/AREVA
POWER CABLES	KEI/ FINOLEX /POLYCAB /APAR
CONTROL CABLES	KEI / DELTON/ FINOLEX /POLYCAB /APAR
LT SWITCHGEAR	L&T / SIEMENS / SCHNEIDER/ABB
STEEL MEMBERS	TATA / VIZA STEEL/SAIL (GI coating done) or any

Equipment	List of Vendor for various BOIs
	equivalent ISI Mark
EARTHING/ LIGHTNING	CG Power/ELPRO INT. LTD/OBLUM
WEATHER MONITORING STATION	KIPP & ZONNEN / EPPLEY / EKO INSTRUMENTS /SOLAR L /GREEN POWER Monitoring
LT POWER PANEL	L&T / SIEMENS / SCHNEIDER/GE POWER
JUNCTION BOX	L&T / PYROTECH / SCHNEIDER
ENERGY METER	SECURE METERS/IMP/BHEL/RISHABH(L&T)
SCADA System	ABB / GE / ROCKWELL
33 kV INDOOR SWITCHGEAR	BHEL BHOPAL
UPS	EMERSON / HITACHI-HIREL / MERLINEGERINE /AEG (SAFT)
BATTERY (Ni-Cd)	HBL POWER SYSTEM
INDUSTRIAL PC ALONGWITH CRT (EWS/ OWS/ SERVER/ HISTORIAN)	DELL / HP (Pavilion)
Printer	HP
ETHERNET SWITCH	CISCO /MOXA
CONTROL PANEL/ LOCAL PANEL	PYROTECH / RITTAL / SCHEINDER / CONTROL & SWITCHGEAR / CONTROL DEVICE / SWITCHING CIRCUIT
OPTICAL FIBRE CABLE	TYCO / MOLEX / BIRLA ERICSSION / HFCL
220 V DC Battery Charger	Exide Battery
Battery Charger	Chloride
36 kV Outdoor VCB	SIEMENS LTD. / ABB INDIA LTD. / SCHNEIDER ELECTRIC / TOSHIBA T&D SYSTEMS (INDIA) / CG POWER & INDUSTRIAL SOLUTION LTD. (FORMERLY KNOWN AS CROMPTON GREAVES LTD.)

SECTION – VI

FORMS

Sl No	Form Name	Form No
01.	Check List	Form-1
02.	Forwarding Letter for submission of Bid Security and Tender Fee	Form -2
03.	Bid Form	Form-3
04.	Bid security (Bank Guarantee format)	Form- 4
05.	Summary Statement Of Yearly Turnover And Net Worth	Form-5
06.	Capability status	Form-6
07.	Statement of similar type of order orders executed as on date of issuance of the NIT	Form-7
08.	Curriculum Vitae Of Key Personnel	Form-8
09.	Format For Submission Of Pre-Bid Queries	Form- 9
10	Proposed modifications	Form-10
11	Joint Venture/Consortium Agreement	Form-11
12	Power of Attorney	Form-12
13	Declaration for Net Minimum Guaranteed Generation	Form-13

FORM-1: CHECK LIST: FORM

Sl. No.	Scanned Copy of Documents to be uploaded	Name of folder	To be submitted in cover	Submitted (Y/N)	If the File name
1.	Tender Fee (Scanned copy)	Drafts	Statutory Cover (Technical proposal)		
2.	Bid Security (Scanned copy)	Drafts	Statutory Cover (Technical proposal)		
3.	Check List (Form - 1)	Forms	Statutory Cover (Technical proposal)		
4.	Forwarding Letter for submission of Bid Security and Tender Fee (Form - 2) (Scanned copy)	Forms	Statutory Cover (Technical proposal)		
5.	Bid Form/Undertaking (Form - 3)	Forms	Statutory Cover (Technical proposal)		
6.	Summary statement of yearly turnover and net worth (Form 5)	Forms	Statutory Cover (Technical proposal)		
7.	Capability Status (Form 6)	Forms	Statutory Cover (Technical proposal)		
8.	Statement of similar type of order orders executed as on date of issuance of the NIT (Form 7)	Forms	Statutory cover (Technical proposal)		
9.	Curriculum Vitae of Key Personnel (Form 8)	Forms	Statutory Cover (Technical proposal)		
10.	Net Minimum Generation Guarantee (Form 13)	Forms	Statutory Cover (Technical proposal)		
11.	Copy of the CST / VAT / TIN Certificate	Certificates	Non-Statutory cover (Technical proposal)		
12.	Copy of the Service Tax Registration Certificate	Certificates	Non-Statutory cover (Technical proposal)		
13.	Copy of the PAN certificate/ PAN Card	Certificates	Non-Statutory cover (Technical proposal)		
14.	Declaration of PF Registration Number or Proof of PF Registration	Certificates	Non-Statutory cover (Technical proposal)		

Sl. No.	Scanned Copy of Documents to be uploaded	Name of folder	To be submitted in cover	Submitted (Y/N)	If the File name
15.	MNRE Chanel partner certificate under "Grid Connected Ground Mounted and Small Solar Power Plants Programme" / Website Download copy from MNRE	Certificates	Non-Statutory cover (Technical proposal)		
16.	Copy of the Registration Certificate under Company Act (Company Incorporation Certificate) or copy of the Registered Deed for Partnership Firm	Company Details	Non-Statutory cover (Technical proposal)		
17.	Copy of the Order(s)/ Contract Agreement(s) with the Purchaser / any other Proof of Purchase, as primary agency AND Corresponding Copy of the Completion Certificate(s) /Commissioning report signed by the Purchaser / Ordering Authority to substantiate the proof of completion of the Solar PV Power Plant(s). (As per declaration in Form-6)	Credential (Technical)	Non-Statutory cover (Technical proposal)		
18.	Copy of the Audited Balance Sheet and Statement of Profit and Loss Account / Tax Audit report as per NIT	(Financial)	Non-Statutory cover (Technical proposal)		
19.	Copy Income Tax return Acknowledgement for assessment years as per NIT	(Financial)	Non-Statutory cover (Technical proposal)		
	Finance Proposal				
20.	BOQ (Financial proposal)	Bill of Quantities (BOQ)	Financial Proposal		
21.	Mode Of Transaction Statement Of Materials and Equipments	Mode of Transaction	Financial Proposal		

Date : (Printed Name).....

Place : (Designation).....

Signed and Upload

FORM-2: FORWARDING LETTER FOR BID SECURITY AND TENDER FEE

Date:

Bidder's Name and address

To

**The Deputy General Manager-IC(M&C)
The West Bengal Power development Corporation Limited**

Bidyut Unnauan Bhaban,
Plot No. 3/C LA-Block,
Sector-III, Bidhannagar,
Kolkata-700 106

Subject : Design & Engineering, Manufacture / Procurement, Supply, Erection, Testing and Commissioning of 10 MW Phase-II Grid Connected Floating Solar Photovoltaic Power Plant on Raw Water Pond No.1,2 & 4 in Sagardighi Thermal Power Project(SgTPP), Murshidabad, West Bengal including warrantee obligation with 05 (Five) years comprehensive Operation and Maintenance.

Reference : NIT No:

Dear Sir,

We are enclosing the following:

1. Account payee Demand draft / Bankers Cheque (No.[insert No.]..... dated [insert date]..... drawn on[insert name of the bank on which drawn]..... for [insert amount in Rs. and words]....., drawn in favor of "**The West Bengal Power Development Corporation Ltd (WBPDCCL)**." payable at Kolkata **towards Tender Fee.**
2. Account payee Demand draft / Bankers Cheque (No.[insert No.]..... dated [insert date]..... drawn on[insert name of the bank on which drawn]..... for[insert amount in Rs. and words]....., drawn in favor of "WBPDCCL" payable at Kolkata **towards Earnest Money (Bid Security) Deposit.**

Or

Bank Guarantee in the prescribed proforma from a scheduled commercial bank in India in favour of WBPDCCL for Rs.[Insert value]...../-valid for a period of one hundred and eighty days (180) days from the bid opening date with a further claim period of thirty (30) days.

[Strike out whichever is not applicable].

Enclosures:

1. (Tender fee : DD / BC in original)
2. (Bid security : DD / BC / BG in original)
3.

Thanking You,

.....

(Signature of authorized signatory)

Name:

Designation:
Date:
Place:

FORM-3: BID FORM/UNDERTAKING

(To be executed on non-Judicial stamp paper of requisite value)

(For genuineness of the information furnished on-line and authenticity of the documents produced before Tender Committee for verification in support of his eligibility)

Reference : NIT No:

I, the undersigned, being the authorized signatory of(Name of the Bidder), having read and examined in detail the NIT including minimum eligibility criteria in particular, instruction to Bidders, general terms & conditions, special terms & conditions and specification, do hereby submitting our offer to execute the contract as per terms & conditions as said forth in your Tender document.

1. We are submitting Tender for the Work _____ against Tender NIT. No. _____
2. We confirm having submitted the eligible criteria as required by you in your Tender Document along with this proposal. In case you require any further information or clarification in this regard, we agree to furnish the same in time.
3. We have submitted the requisite amount of “Tender Fee” of **Rs. XXXXX (Rupees XXXX)** only in form of (DD/BC) on(Bank name) DD/BC no: Dtd:..... Payable at Kolkata
4. We have submitted the requisite amount of Earnest Money (Bid Security) of(**Bid Security Amount**)..... (**Rupees. In Word.....**) only in form of (DD/BC/BG). Detailed as follows :

Mode of Financial Instrument (DD/DC/BG)	Details (No., Name of the Bank etc.)

5. We hereby furnish the following:

1.	Company / Partnership/LLP regeneration	
----	--	--

	i)Registration No:	
	ii) Place of registration:	
2.	i) Central Sales Tax Regn. No:	
	ii)VAT Regn. No:	
3.	Excise Regn. No	
4.	Service Tax Regn. No	
5.	PAN No	
6.	PF A/C No	
7.	Channel partner Certificate No of MNRE Government of India under “Grid Connected Ground Mounted and Small Solar Power Plants Programme” .	

6. Our contact details related to this tender are as follows:

Information	Local office (In West Bengal)	Head office
Name of the Contact Person		
Designation		
Telephone No		
Fax No		
Mobile No		
Email Address		

7. We confirm that our bid in response to the NIT is consistent with all the requirements of submission as stated in the Tender Document and subsequent communications from WBPDC.
8. We confirm none of the Partners of our firm is relative of employee of West Bengal State Electricity Distribution Company Limited (WBPDC).
9. All information furnished by us in respect of fulfillment of eligibility criteria and qualification information of this Tender is complete, correct and true.
10. All documents/ credentials submitted along with this Tender are genuine, authentic, true and valid.
11. If any information and document submitted is found to be false/ incorrect any time, department may cancel my Tender and action as deemed fit may be taken against us, including termination of the contract, forfeiture of all dues including Earnest Money and banning / delisting of our firm and all partners of the firm etc.
12. Should this Bid be accepted, I/We* also agree to abide by and fulfill all the terms

and conditions of provisions of the above mentioned Bidding Documents.

13. We have neither made any statement nor provided any information in this Bid, which to the best of our knowledge is materially inaccurate or misleading. Further, all the confirmations, declarations and representations made in our Bid are true and accurate.
14. We declare that the submitted our offer is without any deviations and are strictly in conformity with the documents issued by WBPDCCL.
15. We declare that content of the Tender Document including NIT, ITB, BDS ,GCC, SCC, Technical Specification and subsequent corrigendum, addendum, if any, are acceptable to us and we have not taken any deviation in this regard. This is to expressly certify that our offer contains **no deviation** either in direct or indirect form.
16. We also declare that in case any deviations are noticed which might have crept inadvertently, that such deviations without reservation of any kind are automatically deemed to have been withdrawn by us.
17. If you accept our offer, we agree to complete the entire work in accordance with work completion time given in the Tender document. We fully understand that the work completion time stipulated in is the essence of the contract, if awarded.
18. We offer to execute the work in accordance with the conditions of the NIT document as available in the website.
19. This Bid and your subsequent Letter of Acceptance / Work Order /agreement shall constitute a binding contract between us.
20. We hereby confirm our acceptance of all terms and conditions of the NIT document unconditionally.
21. We also declare that, we have never been blacklisted and / or there were no debarring actions against us as on date due to any reason what-so-ever, by any Government or Government Agencies. In the event of any such information pertaining to the aforesaid matter found at any point of time either during the course of the contract or at the bidding stage, our bid/contract will be liable for truncation / cancellation / termination without any notice at the sole discretion of WBPDCCL.

Date : (Printed Name).....

Place : (Designation).....

Signed and Upload

FORM-4: BID SECURITY

FORM FOR BID SECURITY

BANK GUARANTEE FORMAT FOR EMD/ BID SECURITY

(To be stamped in accordance with Stamp Act, if any, of the Country of the issuing Bank)

Bank Guarantee No.: _____

Date: _____

To,

The GM(M&C)

The West Bengal Power Development Corporation Limited

Bidyut Unnayan Bhaban, Block- LA, Plot No. 3/C, Sector-III,

Salt Lake City, Kolkata- 700106, West Bengal, India.

Dear Sir,

In accordance with your NIT No. _____ M/s XXX (Name of Participating Contractor) having its Registered Head Office at _____ (hereinafter called the Bidder) wish to participate in the said RFP/NIT for _____ (Name of Job).

As an irrevocable Bank Guarantee against Bid Security for an amount of ____ is required to be submitted by the Bidder as a condition precedent for participation in the said Tender, which amount is liable to be forfeited on the happening of any contingencies mentioned in the Tender Document, we, the _____ Bank at _____ having our Head Office / Registered Office at _____ (Address of Bank) guarantee and undertake to pay immediately on demand by the West Bengal Power Development Corporation Limited the amount of _____ (in words and figures) without any reservation, protest, demur and recourse. Any such demand made by said Procuring Entity shall be conclusive and binding on us irrespective of any dispute of difference raised by the Bidder.

This Guarantee shall be irrevocable and shall remain valid up to Date _____ (six months from the Closing date of submission of bid) with a claim period of another 3(three) months. If any further extension of this guarantee is required, the same shall be extended to such required period on receiving instructions from M/s XXX (Participating Bidder) on whose behalf this Guarantee is issued.

All rights of the West Bengal Power Development Corporation Limited under this Guarantee shall be forfeited and the Bank shall be relieved and discharged from all liabilities there under unless the WBPDCCL brings any suit or action to enforce a claim under this Guarantee against the Bank within ninety (90) calendar days from the above mentioned expiry date of validity or, from that of the extended date.

In witness whereof the Bank, through its authorised Officer, has set its hand and stamp on this _____ day of _____ Year at _____.

WITNESS:

(Signature and Name) (Signature and Name)

(Engineer / Officer address) (Designation with Bank Stamp)

Attorney as per Power of Attorney No. _____

Date:

FORM-5: SUMMARY STATEMENT OF YEARLY TURNOVER AND NET WORTH

NIT No:

Bidder's Name & Address:

This is to certify that the following statement is the summary of the Audited /Tax audited Accounts of our Company/firm (The Bidder) arrived for the three consecutive years or for such period since inception of the Firm, if it was set in less than such three year's period as follows:

Sl. No.	Financial		Remarks
	Year	Turnover rounded up to in lakh (two digit after decimal)	
1.	20.. - 20..		
2.	20... - 20.....		
3.	20... - 20.....		
5.	Net Worth as at last financial Year		

Note:

1. Average turnover is to be expressed in rupees in lakh, rounded up to two digits after decimal.
2. The statement must be the individual bidder's turnover and not the consolidation as the result of accounts of group and associates.
3. Average turnover for 3 years is to be obtained by dividing the total turnover by 3.0. If the bidder was set up in less than 3 year's period, consider the turnover for the period from inception to the Year-1. It may be either 1.0 or 2.0. Average turnover is to be obtained by dividing the total turnover by 1.0 or 2.0, as the case may be.
4. In case, the bidder was set up in less than 3 year's period, mention the year of inception in the 'Remarks' column.

Signed and Upload

FORM-6: CAPABILITY STATUS

NIT No:

Bidder's Name & Address:

To

The GM(M&C)

The West Bengal Power Development Corporation Limited

Bidyut Unnayan Bhaban, Block- LA, Plot No. 3/C, Sector-III,

Salt Lake City, Kolkata- 700106, West Bengal, India.

Subject : Design & Engineering, Manufacture / Procurement, Supply, Erection, Testing and Commissioning of 10 MW Phase-II Grid Connected Floating Solar Photovoltaic Power Plant on Raw Water Pond No.1,2 & 4 in Sagardighi Thermal Power Project(SgTPP), Murshidabad, West Bengal including warrantee obligation with 05 (Five) years comprehensive Operation and Maintenance.

We provide the following details to conform that we have sufficient capacity to execute the supply of Goods covered in the NIT:

A	Manufacturing Capacity (applicable in case of original manufacturers only)	
B	Orders in Hand	
i	Total value of Orders	
ii	Value of work completed out of above value upto 31.01.2018.	

Details of orders in hand are as follows:

Sl. No	Purchaser / Client	Scope of works	Order Value	Schedule Time of Completion	Value of Outstanding work	Estimated Completion date

Note:

- Continuation sheets of like size and format may be used and annexed to this format if required.

Date : (Printed Name).....

Place : (Designation).....

Signed and Upload

FORM-7: SIMILAR TYPE OF ORDERS

STATEMENT OF SIMILAR TYPE OF ORDERS EXECUTED AS ON DATE OF ISSUANCE OF THE NIT

[Applicability up to the extent of meeting Technical QR].

NIT No:

Bidder's Name & Address:

To

The Deputy General Manager-IC(M&C)
The West Bengal Power development Corporation Limited

Bidyut Unnauan Bhaban,
Plot No. 3/C LA-Block,
Sector-III, Bidhannagar,
Kolkata-700 106

Subject : Design & Engineering, Manufacture / Procurement, Supply, Erection, Testing and Commissioning of 10 MW Phase-II Grid Connected Floating Solar Photovoltaic Power Plant on Raw Water Pond No.1,2 & 4 in Sagardighi Thermal Power Project(SgTPP), Murshidabad, West Bengal including warrantee obligation with 05 (Five) years comprehensive Operation and Maintenance.

Sl No	Name of the Installed Plants/ Project	Financial year	Order No. and date	Name of Purchaser / order issuing authority	Cumulative capacity of the order (Considering similar type of work) (scanned copy of certificate to be Submitted in non-statutory cover) (kWp)	Ordered Value/Time (extended time, if any) of Completion	Cumulative capacity installed (Considering similar type of work) (kWp)	Completion report of installed systems (scanned copy of certificate to be Submitted in non-statutory cover)	Remarks

- Continuation sheets of like size and format may be used and annexed to this format if required.

Similar type of work means Solar PV power plant each of minimum capacity as per QR of the tender

Date : (Printed Name).....

Place : (Designation).....

Signed and Upload

FORM-8: CURRICULUM VITAE OF KEY PERSONNEL

NIT No:

Bidder's Name & Address:

To

The General Manager(M&C)

The West Bengal Power development Corporation Limited

Bidyut Unnauan Bhaban,

Plot No. 3/C LA-Block,

Sector-III, Bidhannagar,

Kolkata-700 106

Subject : Design & Engineering, Manufacture / Procurement, Supply, Erection, Testing and Commissioning of 10 MW Phase-II Grid Connected Floating Solar Photovoltaic Power Plant on Raw Water Pond No.1,2 & 4 in Sagardighi Thermal Power Project(SgTPP), Murshidabad, West Bengal including warrantee obligation with 05 (Five) years comprehensive Operation and Maintenance.

S.No	Proposed Position	Name	Position Held since	Professional Qualification	Experience in relevant Field	Any other Information

Date : (Printed Name).....

Place : (Designation).....

Signed and Upload

Note:

- Continuation sheets of like size and format may be used and annexed to this Form if required.

FORM-9: FORMAT FOR SUBMISSION OF PRE-BID QUERIES

FORMAT FOR SUBMISSION OF PRE-BID QUERIES			
NIT No.		DTD.	
Subject : Design & Engineering, Manufacture / Procurement, Supply, Erection, Testing and Commissioning of 10 MW Phase-II Grid Connected Floating Solar Photovoltaic Power Plant on Raw Water Pond No.1,2 & 4 in Sagardighi Thermal Power Project(SgTPP), Murshidabad, West Bengal including warrantee obligation with 05 (Five) years comprehensive Operation and Maintenance.			
NAME OF THE BIDDER:	<To be filled in by the bidder>	Work name : <To be filled in by the bidder>	
PART A - TECHNICAL QUERIES			
Sl no	GCC Clause reference (if any)	BIDDER'S QUERY	WBPDCCL's REPLY
1			
2			
3			
PART B: COMMERCIAL/GCC RELATED/CONTRACTUAL QUERIES			
Sl no	GCC Clause reference (if any)	BIDDER'S QUERY	WBPDCCL's REPLY
1			
2			
3			
4			
5			
<ul style="list-style-type: none"> • Continuation sheets of like size and format may be used as per Bidders requirements and shall be annexed to this Form. 			

Note:

- i. To be submitted before Pre- bid meeting.
- ii. This sheet must not be the part of the offer submitted by the bidder and not to be upload
- iii. This sheet to be mailed in Excel Format at email address : s.sengupta@wbpdcl.co.in

Date :	(Signature).....
Place :	(Authorized Representative of bidder)..
	(Designation).....
	Name of the bidder:

FORM-10: PROPOSED MODIFICATIONS

(To be submitted before Pre-bid meeting)

Ref:

Bidder's Name & Address:

To

The General Manager (M&C)
The West Bengal Power development Corporation Limited
Bidyut Unnauan Bhaban,
Plot No. 3/C LA-Block,
Sector-III, Bidhannagar,
Kolkata-700 106

Subject : Design & Engineering, Manufacture / Procurement, Supply, Erection, Testing and Commissioning of 10 MW Phase-II Grid Connected Floating Solar Photovoltaic Power Plant on Raw Water Pond No.1,2 & 4 in Sagardighi Thermal Power Project(SgTPP), Murshidabad, West Bengal including warrantee obligation with 05 (Five) years comprehensive Operation and Maintenance.

Reference : NIT No: _____

We have carefully gone through the Technical Specifications and the General Conditions of Contract and we have satisfied ourselves and hereby propose certain modifications as mentioned below:

S.No.	Sec./Clause & Page No.	Existing Clause	Modified clause (proposed by Bidder)	Reasons for modification

Note:

- i. To be submitted before Pre- bid meeting.
- ii. This sheet must not the part of the offer submitted by the bidder and not to be upload
- iii. This sheet to be mailed in Excel Format at email address : s.sengupta@wbpdcl.co.in

Date : _____ **(Signature)**.....
(Authorised Representative of bidder)

Place : _____
(Designation).....

Name of the bidder:

FORM-11: PROFORMA FOR JOINT VENTURE/CONSORTIUM AGREEMENT

(ON NON-JUDICIAL STAMP PAPER OF APPROPRIATE VALUE)

This Joint Venture/Consortium Agreement made and entered into on _____ day of..... (year)

BY AND BETWEEN _____ (Name of the Lead Member), a Company/Firm registered under the laws of _____ (Name of the Country) with its Head/Registered Office at _____ (Address of the Head/Registered Office) and a place of business in _____ (Address of place of business) (hereinafter referred to as "The Lead Member") and represented by Mr/Mrs/Ms. _____ (Name of Authorized Signatory).

AND

_____ (Name of the other Member), a Company/Firm registered under the laws of _____ (Name of the Country) with its Head/Registered Office at _____ (Address of the Head/Registered Office) and a place of business in _____ (Address of place of business) (hereinafter referred to as "The Member") and represented by Mr/Mrs/Ms. _____ (Name of Authorized Signatory).

WITNESSETH

WHEREAS WEST BENGAL POWER DEVELOPMENT CORPORATION LIMITED (hereinafter referred to as "The Procuring Entity") has issued RFP/ Notice Inviting Tender No. _____ Dated _____ for (.....Name of the Job.....). The Procuring Entity intends to select the suitable Bidder through competitive bidding process for the aforesaid Project/Works / Services.

WHEREAS the Parties are interested in jointly preparing and submitting an Application to Bid for the Project/ Works / Services mentioned above as a Joint Venture/Consortium.

1.0 PURPOSE OF THIS AGREEMENT

1.1. The purpose of this Agreement is to define the principles of collaboration among the Parties to:

1.1.1 Submit an Application jointly to Bid for the (.....Name of the Job.....) as a Joint Venture / Consortium.

1.1.2 Negotiate and sign Contract in case of award.

1.1.3 Provide and perform the supplies / works / services / EPC etc. which would be ordered by the Procuring Entity pursuant to the Contract.

1.2. For the purpose of participating in the Bid, the name of the Joint Venture /Consortium shall be “_____”.

2.0 LEGAL RELATIONSHIP OF THE MEMBERS

2.1. This Agreement shall not be construed as establishing or giving effect to any legal entity such as, but not limited to, a company, a partnership, etc. It shall relate solely towards the Procuring Entity for (.....Name Of the Job.....) and related execution works to be performed pursuant to the Contract and shall not extend to any other activities.

2.2. The Parties shall be jointly and severally responsible and bound towards the Procuring Entity for the performance of the Job in accordance with the terms & conditions of the Tender Document and Contract.

3.0 LEAD MEMBER

_____ (Name of Member) shall act as Lead Member of the Joint Venture /Consortium. As such, it shall act as the coordinator of the Members’ combined activities and shall carry out the following functions:

- 3.1.To ensure the technical, commercial and administrative co-ordination of the Project/Works / Services.
- 3.2.To lead the contract negotiations of the Project/ Works / Services with the Procuring Entity.
- 3.3.The Lead Member is authorized to submit bills, receive payments and instructions and incur liabilities for and on behalf of Joint Venture /Consortium Members.
- 3.4.In case of an award, act as a channel of communication between the Procuring Entity and the Joint Venture /Consortium to execute the Contract.

4.0 SCOPE OF WORK AND SERVICES OF EACH MEMBER

4.1 Scope of Work and Services: The Scope of Work and Services for each Member shall be defined as follows:

4.1.1. _____ (Name of Member) shall be responsible for the following (Define the Scope of Work):

- a)
- b)

4.1.2. _____ (Name of Member) shall be responsible for the following (Define the Scope of Work):

a)

b)

4.1.3. _____ (Name of Member) shall be responsible for the following (Define the Scope of Work):

a)

b)

4.2 Participation Share of each Member:

Lead Member _____ %

Other Member _____ %

Other Member _____ %

4.3 Financial Commitment of each Member in terms of Contract Value:

Lead Member _____ %

Other Member _____ %

Other Member _____ %

5.0 SECURITIES

Securities, in the form of Bank Guarantees or any other mode as required under the Tender Document and/or Contract shall be provided in the following manner.

Lead Member _____ Rs.

Other Member _____ Rs.

Other Member _____ Rs.

6.0 LIABILITY

Liability of the Parties with respect to Claims of the Procuring Entity: All the joint venture/consortium members are jointly and severally liable to the Procuring Entity for the Performance in terms of Scope of Work under the Contract in its entirety.

7.0 DURATION OF THE AGREEMENT

The present Agreement is valid until successful completion of the Contract including defect liability period, if any, and full and final settlement of all accounts and disputes, if any, between the Parties and the Procuring Entity, except if the Procuring Entity has decided not to award the Contract to the Parties, in such case the Parties are free from any obligation under this Agreement.

IN WITNESS WHEREOF, this agreement executed on the _____ day of _____
(month)..... (Year) by the duly Authorized Representatives of the Parties hereto.

For and on behalf of M/s. _____

(Lead Member)

Name:

Company Seal:

For and on behalf of M/s. _____

(Other Member)

Name:

Company Seal:

For and on behalf of M/s. _____

(Other Member)

Name:

Company Seal:

Notary Seal:

FORM-12: POWER OF ATTORNEY

Format for Power of Attorney to be provided by each of the other members of the Consortium in favour of the Lead Member

(To be on non-judicial stamp paper of appropriate value as per Stamp Act relevant to place of execution)

Whereas the West Bengal Power Development Corporation Ltd. (WBPDC) (the "Procuring Entity") has invited Bids from bidders for " EPC Contract for Design & Engineering, Manufacture / Procurement, Supply, Installation, Testing and Commissioning of 10 MW Grid connected Floating Solar Photovoltaic Power Plants on Raw Water Pond No.1, 2 & 4 in Sagardighi Thermal Power Project(SgTPP), Murshidabad, West Bengal, India in turnkey basis including warrantee obligation with 05 (Five) years comprehensive Operation and Maintenance"

Whereas, M/s....., and M/s..... (collectively the "**Joint Venture/ Consortium**") being Members of the Joint Venture/ Consortium are interested in bidding for the Project in accordance with the terms and conditions of the tender document and other Bid documents including agreement in respect of the Project/works/services,

AND

Whereas, it is necessary for the Members of the Joint Venture/ Consortium to designate one of them as the Lead Member with all necessary power to do for and on behalf of the Joint Venture/ Consortium, all acts, deeds and things as may be necessary in connection with the Joint Venture's/ Consortium's Bid for the Project/Works/Services and its execution.

NOW THEREFORE KNOW ALL MEN BY THESE PRESENTS

We, M/s..... having our registered office at, and M/s..... having our registered office at, (hereinafter collectively referred to as the "**Principals**") do hereby irrevocably designate, nominate, appoint and authorize M/s having its registered office at, being one of the Members of the Joint Venture/ Consortium, as the Lead Member and true and lawful attorney of the Joint Venture/ Consortium (hereinafter referred to as the "**Attorney**"). We hereby irrevocably authorize the Attorney (with power to sub-delegate) to conduct all business for and on behalf of the Joint Venture/ Consortium and any one of us during the Bidding process and, in this regard, to do on our behalf and on behalf of the Joint Venture/ Consortium, all or any of such acts, deeds or things as are necessary or required or incidental to the Bid, including but

not limited to signing and submission of all applications, Bids and other documents and writings, participate in meetings, respond to queries, submit information/ documents, sign and generally to represent the Joint Venture/ Consortium in all its dealings with the Procuring Entity, in all matters in connection with or relating to or arising out of the Joint Venture's/ Consortium's Application.

AND hereby agree to ratify and confirm and do hereby ratify and confirm all acts, deeds and things done or caused to be done by our said Attorney pursuant to and in exercise of the powers conferred by this Power of Attorney and that all acts, deeds and things done by our said Attorney in exercise of the powers hereby conferred shall and shall always be deemed to have been done by us(Joint Venture/ Consortium).

IN WITNESS WHEREOF WE THE PRINCIPALS ABOVE NAMED HAVE EXECUTED THIS POWER OF ATTORNEY ON THIS DAY OF 20...

For

(Signature)

.....

(Name & Title)

For

(Signature)

.....

(Name & Title)

For

(Signature)

.....

(Name & Title)

(Executants)

(To be executed by all the Members of the Joint Venture/ Consortium)

Witnesses:

1.

2.

Notes:

1. The mode of execution of the Power of Attorney should be in accordance with the procedure, if any, laid down by the applicable law and the charter documents of the executants (s) and when it is so required, the same should be under common seal affixed in accordance with the required procedure.

2. Also, wherever required, the Bidder should submit for verification the extract of the charter documents and documents such as a board or shareholders' resolution/ power of attorney in favour of the person executing this Power of Attorney for the delegation of power hereunder on behalf of the Bidder.

**FORM-13: DECLARATION FOR NET MINIMUM
GUARANTEED GENERATION**

DECLARATION SHEET – FOR NET MINIMUM GUARANTEED GENERATION
(To be submitted on official letter head by the bidder)

We declare that the (project description) offered by us within the scope of this tender, will generate minimum 1.52MU/MWp/year measured in the Net Meter installed at the outgoing feeder. The Net Minimum Guaranteed Generation shall be calculated after deducting the Auxiliary Consumption for the plant.

The Net Minimum Guaranteed Generation shall be reduced @ 1% per year.

In case we fail to produce the Net Minimum Guaranteed Generation as stated above, the provisions of penalty according to Clause No. 4.3.5 of the Special Conditions of Contract of this tender shall be applicable.

I hereby certify that I am duly authorized representative of the Bidder whose name appears above my signature.

Bidder's Name:

Authorised Representative's Signature.....

SECTION – VII

ANNEXURES

Sl No	Annexure Name	Annexure No
01.	Proforma Of Contract Agreement	Annexure-1
02.	Proforma Of Bank Guarantee For Contract Performance	Annexure-2
03.	Proforma Of Bank Guarantee For Mobilisation Advance	Annexure-3
04.	Proforma For Extension Of Bank Guarantee	Annexure-4
05.	Proforma Of Indemnity Bond	Annexure -5
06	Completion Certificate	Annexure-6
07	Application for Payments	Annexure-7
08	Taking-Over Certificate	Annexure-8
09	No-Claim Certificate	Annexure-9
10	Indemnity bond to be executed by the contractor for the equipment handed over by the Purchaser for performance of its contract (Entire Equipment Consignment in one lot)	Annexure-10A
11	Application for Material Gate Pass	Annexure-10B
12	Authorization letter	Annexure-11
13	Material Receipt Certificate	Annexure-12

ANNEXURE-1: CONTRACT AGREEMENT

PROFORMA OF CONTRACT AGREEMENT

(To be executed on Non-Judicial Stamp Paper of Rs. 100/-)

THIS AGREEMENT made at this _____ day of _____, _____, between **The West Bengal Power Development Corporation Limited of Plot No. 3/C LA-Block, Sector-III, Bidhannagar, Kolkata-700 106** (hereinafter called “the Procuring Entity”), of the one part, and _____ of _____ (hereinafter “the Contractor”), of the other part:

WHEREAS the Procuring Entity invited bids “<Tender Description> in WBPDC” and has accepted the Bid offered by the Bidder/Contractor for the same in the sum of _____ (hereinafter “the Contract Price”). After due consideration, the procuring entity has decided to entrust to the contractor with the job/ work/ supply of “**Design & Engineering, Manufacture / Procurement, Supply, Erection, Testing and Commissioning of 10MW Phase-II Grid Connected Floating Solar Photovoltaic Power Plant on Raw Water Pond No.1, 2 & 4 in Sagardighi Thermal Power Project(SgTPP), Murshidabad, West Bengal including warrantee obligation with 05 (Five) years comprehensive Operation and Maintenance**”

FOR THE CONSIDERATION payable under this agreement, the contractor hereby agrees to complete the execution of job/ work/ supply in a satisfactory manner following scope of Work within the specified period.

NOW THIS AGREEMENT WITNESSETH AS FOLLOWS:

1. In this Agreement words and expressions shall have the same meanings as are respectively assigned to them in the Contract referred to.
2. The following documents shall be deemed to form and be read and construed as part of this Agreement, viz.:
 - a) the Procuring Entity’s Notification (LoA) to the Contractor of Award of Contract;
 - b) the Bid Forms(including Price Bid) submitted by the Contractor;
 - c) the Special Conditions of Contract;
 - d) the General Conditions of Contract;
 - e) _____
 - f) _____

This Contract shall prevail over all other Contract documents which are not covered under Clause 2 above. In the event of any discrepancy or inconsistency within the

Contract documents referred under Clause 2, then the contract shall be governed by the documents in the order listed above.

3. In consideration of the payments to be made by the Procuring Entity to the Contractor as indicated in this Agreement, the Contractor hereby covenants with the Procuring Entity to provide the goods and services / to execute works and to remedy defects therein in conformity with the provisions of the Contract in all respects.
4. The Procuring Entity hereby covenants to pay the Contractor in consideration of the provision of the goods and services / execution of works and the remedying of defects therein, the Contract Price or such other sum as may become payable under the provisions of the Contract at the times and in the manner prescribed by the Contract.

IN WITNESS WHEREOF, the parties through their duly authorized representatives have executed these presents (execution whereof has been approved by the competent authorities of both the parties) on the day, month and year first above mentioned at Kolkata.

Signed by for and on behalf of the Procuring Entity
.....
[Signature]

.....
[Title]

In the presence of
..... (Signature, Name and Title)

Signed by for and on behalf of the Contractor/ Lead Member
.....
[Signature]

.....
[Title]

In the presence of
..... (Signature, Name and Title)

ANNEXURE-2: BG (CONTRACT PERFORMANCE)

PROFORMA OF BANK GUARANTEE FOR CONTRACT PERFORMANCE

(To be executed in non-judicial stamp paper of Rs. 100/-)

(To be stamped in accordance with Stamp Act, if any, of the Country of the issuing Bank)

Bank Guarantee No.: _____

Date: _____

To,

**The West Bengal Power Development Corporation Limited
Plot No. 3/C LA-Block, Sector-III, Bidhannagar, Kolkata-700 106**

Dear Sir,

In consideration of the West Bengal Power Development Corporation Limited (Hereinafter referred to as the 'Procuring Entity' which expression shall unless repugnant to the context or meaning thereof, include its successors, administrators and assigns) having awarded to M/s..... [*Contractor's Name*]..... With its Registered/Head Office at..... (Hereinafter referred to as the 'Contractor', which expression shall unless repugnant to the context or meaning thereof, include its successors administrators, executors and assigns), a Contract by issue of *Procuring Entity's* Letter of Acceptance No. dated and the same having been acknowledged by the Contractor, for [Contract sum in figures and words] for [*Name of the work*] and the Contractor having agreed to provide a Contract Performance Guarantee for the faithful performance of the entire Contract equivalent to (*)..... of the said value of the aforesaid work under the Contract to the Procuring Entity.

We..... [*Name & Address of the Bank*]..... having its Head Office at..... (hereinafter referred to as the 'Bank', which expression shall, unless repugnant to the context of meaning thereof, include its successors, administrators, executors and assigns) do hereby guarantee and undertake to pay the *Procuring Entity* on demand any and all monies payable by the Contractor to the extent of (*) as aforesaid at any time upto..... (@) [*days/month/year*] without any demur, reservation, contest, recourse or protest and/or without any reference to the Contractor. Any such demand made by the *Procuring Entity* on the Bank shall be conclusive and binding notwithstanding any difference between the *Procuring Entity* and the Contractor or any dispute pending before any Court, Tribunal, Arbitrator or any other authority. The Bank undertakes

not to revoke this guarantee during its currency without previous consent of the *Procuring Entity* and further agrees that the guarantees herein contained shall continue to be enforceable till the *Procuring Entity* discharges this guarantee or till[days/month/year] whichever is earlier.

The *Procuring Entity* shall have the fullest liberty, without affecting in any way the liability of the Bank under this guarantee, from time to time to extend the time for performance of the Contract by the Contractor. The *Procuring Entity* shall have the fullest liberty, without affecting this guarantee, to postpone from time to time the exercise of any powers vested in them or of any right which they might have against the Contractor, and to exercise the same at any time in any manner, and either to enforce or to forbear to enforce any covenants, contained or implied, in the Contract between the Procuring Entity and the Contractor or any other course or remedy or security available to the Procuring Entity. The Bank shall not be released of its obligations under these presents by any exercise by the Procuring Entity of its liberty with reference to the matters aforesaid or any of them or by reason of any other act or forbearance or other acts of omission or commission on the part of the *Procuring Entity* or any other indulgence shown by the *Procuring Entity* or by any other matter or thing whatsoever which under law would, but for this provision have the effect of relieving the Bank.

The Bank also agrees that the Procuring Entity at its option shall be entitled to enforce this Guarantee against the Bank as a principal debtor, in the first instance without proceeding against the Contractor and notwithstanding any security or other guarantee the Procuring Entity may have in relation to the Contractor's liabilities.

Our liability under this Bank Guarantee shall not exceed

This Bank Guarantee shall be valid up to and including

We are liable to pay the guaranteed amount or any part thereof under this Bank Guarantee only and only if Procuring Entity serve upon Bank a written claim or demand on or before@..... Dated this..... Day of(Month)..... (Year)..... at.....

WITNESS

.....

(Signature)

.....

(Name)

.....

(Signature)

.....

(Name)

.....
(Engineer / Officer Address) (Designation with Bank Stamp)
.....
Attorney as per Power of Attorney No.....

Dated.....

Notes:

1. (*) This sum shall be 10% (ten percent) of the Contract Price.
2. (@) This date will be Ninety (90) calendar days beyond the defects liability period as specified in the Contract.
3. The stamp papers of appropriate value shall be purchased in the name of guarantee issuing Bank.

ANNEXURE-3: BG (MOBILISATION ADVANCE)

PROFORMA OF BANK GUARANTEE FOR MOBILISATION ADVANCE

(To be executed in non-judicial stamp paper of Rs. 100/-)

(To be stamped in accordance with Stamp Act, if any, of the Country of the issuing Bank)

Bank Guarantee No.: _____

Date: _____

To,

The West Bengal Power Development Corporation Limited
Plot No. 3/C LA-Block, Sector-III, Bidhannagar, Kolkata-700 106

We have been informed that _____ (hereinafter called “the Contractor”) has entered into Contract No.: _____ dated _____ with you, for the execution of _____ (hereinafter called “the Contract”).

Furthermore, we understand that, according to the conditions of the Contract, an advance payment in the sum of Rs. _____/- (_____) is to be made against an advance payment guarantee.

At the request of the Contractor, we _____ hereby irrevocably undertake to pay you any sum or sums not exceeding in total an amount of Rs. _____/- (_____) upon receipt by us of your first demand in writing accompanied by a written statement stating that the Contractor is in breach of its obligation under the Contract because the Contractor used the advance payment for purposes other than toward the execution of the Works.

It is a condition for any claim and payment under this guarantee to be made that the advance payment preferred to above must have been received by the Contractor on his account number _____ at _____.

The maximum amount of this guarantee is valid shall be progressively reduced in proportion to the value of each part-shipment or part-delivery of plant and equipment to the site, as indicated in copies of the relevant shipping and delivery documents that shall be presented to us. This guarantee shall expire, at the latest, upon our receipt of documentation indicating full repayment by the Contractor of the amount of the advance payment, or on the ____ day of _____, 2____, whichever is earlier. Consequently, any demand for payment under this guarantee must be received by us at this office on or before that date.

This guarantee is subject to the Uniform Rules for Demand Guarantees, ICC Publication No.: 458.

[Signature(s) name of bank or financial institution]

ANNEXURE-4: FOR EXTENSION BG

PROFORMA FOR EXTENSION OF BANK GUARANTEE

Ref......

Date.....

To

.....
.....

..... West Bengal

Sub: Extension of Bank Guarantee No.....for
Rs..... favoring yourselves, expiring
on.....on account of
M/s.....in respect of
Contract No.....dated..... (hereinafter called
original Bank Guarantee).

Dear
Sirs,

At the request of M/s.....,We.....Bank, branch
office at.....and having its Head Office
at.....do hereby extend our liability under the above
mentioned Bank Guarantee No..... dated..... for a further
period of.....(Years/Months) from.....to expire
on.....Expect as provided above, all other terms and conditions of the
original bank guarantee No.....dated.....shall remain unaltered
and binding.

Please treat this as an integral part of the original bank guarantee to which it would be attached. Yours Faithfully,

For

Manager/Agent/Accountant..... Power of Attorney

No..... Dated.....

SEAL OF BANK

NOTE: The non-judicial stamp paper of appropriate value shall be purchased in the name of the bank who has issued the Bank Guarantee.

ANNEXURE-5: INDEMNITY BOND

PROFORMA OF INDEMNITY BOND

(To be executed on Non-Judicial Stamp Paper of Rs. 100/-)

BY THE PRESENT INDEMNITY BOARD EXECUTED by me/us on this.....Day of.....20.....,I/We having Registered Office / residing at.....(herein after called "OBLIGOR/OBLIGORS" which expression shall mean and includes my/our successors legal representatives, assigns) do hereby binds myself/ourselves and also our company/firm..... after having the power to bind so with the promise and undertaking in favour of 'The West Bengal Power development Corporation Limited' Bidyut Unnauan Bhaban, Plot No. 3/C LA-Block, Sector-III, Bidhannagar, Kolkata-700 106 (hereinafter called as OBLIGEE, which expression shall mean and include it's legal representative, administrators assigns.

Whereas OBLIGOR/OBLIGORS has/have been awarded to execute the job/works under letter no.....dated.....issued by the OBLIGEE after having observing necessary formalities, the details of which is described in the schedule given here under as per letter mentioned herein-above and whereas the said job/works will be/likely to be done in places covered under Employees' State Insurance Act (ESI) and/or the Employee Compensation Act, 1923 (W.C. Act) and/or other laws relating to the Labour Management and Welfare.

And whereas according to the condition of the contract the OBLIGOR/OBLIGORS is/are under obligation to execute this Indemnity Bond before the commencement of actual execution and OBLIGOR/OBLIGORS is/are aware that unless this Indemnity Bond is executed in accordance with the condition of contract before the actual execution in accordance with law the OBLIGEE shall have the power to deem that actual work has been stated within the meaning of the contract before the execution

of this Indemnity Bond.

Now this indenture witnesses that I/we the OBLIGOR/OBLIGORS do hereby undertake:

1. THAT the OBLIGEE shall not be held responsible for any type of accident which may take place during the course of work undertaken by the OBLIGOR/OBLIGORS.
2. THAT the OBLIGOR/OBLIGORS will take/adopt all safety norms in respect of each and every workmen labour personnel according to the rules or to the satisfaction of the OBLIGEE IN ALL CASES.
3. That the OBLIGOR/OBLIGORS undertakes/undertake to engage only those labour worker or any other personnel whether skilled or unskilled or any other person whether in technical management or non-managerial or any other capacity in the area covered under Employee' State Insurance Act, 1948 who has/have insurance coverage within the meaning of Employees' State Insurance Act and further undertakes NOT to engage any person in the area covered under Employees State Insurance Act., who does/do not has/have insurance coverage within the meaning of Employees' State Insurance Act,1948.
4. That the OBLIGOR/OBLIGORS further undertakes/undertake to engage only those labour, worker, or any other personnel, whether skilled or unskilled, whether in technical, managerial or non-managerial or any other capacity in the area NOT covered under Employees' State Insurance Act 1948, who has life insurance for the sum assured equivalent to the amount of Compensation under the Employees Compensation Act in case of accidental death or inquiry and such insurance has been effected by the OBLIGOR/OBLIGORS.
5. THAT the OBLIGOR/OBLIGORS undertakes/undertake to indemnify and keep harmless the OBLIGEE from all claims, action, proceedings and of risk, damage, danger to any person whether belonging to/or not belonging to OBLIGOR/OBLIGORS.
6. THAT the OBLIGOR/OBLIGORS shall keep harmless the OBLIGEE from all claims, compensation, damages, any proceedings in respect of any of its employee/workmen under the Employee Compensation Act or any other laws for the time being in force.
7. THAT, if during the course of execution of work as stated in the letter mentioned hereinabove issued by the OBLIGEE, it is found that the OBLIGOR/OBLIGORS has/have not complied with guidelines/formalities within the meaning of Employees' State Insurance Act or Employee Compensation Act or any other laws relating to the Labour Welfare for the time being in force, and also has not observed the safety norms in accordance with the law to the satisfaction of the OBLIGEE, the OBLIGEE shall have the right to stop the execution of work/job and the period of

such stoppage shall continue till adequate safety and other compliance mentioned hereinabove under the labour welfare legislation have been observed and such period of stoppage shall not be taken into account for the calculation of the total period of completion of work for which the OBLIGOR/OBLIGORS is responsible to complete the work/job and it will be deemed that discontinuance was due to default of OBLIGOR / OBLIGORS.

8. THAT, if at any time, due to exigency, the OBLIGEE i.e. the West Bengal Power Development Corporation Limited(WBPDCCL) as the Principal Employer, becomes liable to pay any such compensation mentioned hereinabove, whether on failure of the OBLIGOR/OBLIGORS or for any other reason, the OBLIGEE shall have the right to recover the said amount from any amount receivable by OBLIGOR/OBLIGORS or any bank guarantee deposited or anything payable whether in connection with this contract or other contract by the OBLIGEE to the OBLIGOR/OBLIGORS.
9. THAT the OBLIGOR/OBLIGATOR is/are aware and accept that for the persistent or repeated violation of any condition mentioned in this Indemnity Bond, the OBLIGEE shall have right to terminate the contract of work issued by the OBLIGEE to OBLIGOR/OBLIGATOR.

SIGNED AND DELIVERED

BY THE OBLIGOR/OBLIGORS

Signature

WITNESS:

1) Name & Designation

Signature

1) Name & Designation

Signature

ANNEXURE-6: COMPLETION CERTIFICATE

Completion Certificate

(On the letter head of the Purchaser as per provisions of GCC 3.32)

Date:

Contract No.:

[Name of Contract]

To: [Name and address of Contractor]

Dear Sirs,

Pursuant to Clause GCC 3.32 of the General Conditions of the Contract entered into between yourselves and the WBPDC dated [date], relating to the [brief description of the Works], we hereby notify you that the following part(s) of the Works was (were) complete on the date specified below, and that, in accordance with the terms of the Contract, the Purchaser hereby takes over the said part(s) of the Works, together with the responsibility for care and custody and the risk of loss thereof on the date mentioned below.

1. Description of the Works or part thereof: [description]

Billing Schedule Sl. No.	Description of item	Total	Quantity/Percentage (%)		
			Cumulative achieved up to last bill	Claimed in this bill	Cumulative achieved up to date

2. Date of Completion: [date]

3. Defects to be rectified, if any:

However, you are required to complete the outstanding items listed in the enclosure hereto as soon as practicable.

This letter does not relieve you of your obligation to complete the execution of the Works including Guarantee Test(s) in accordance with the Contract nor of your obligations during the Defects Liability Period.

Very truly yours,

.....

Title
(Project Manager)

Encl: List of outstanding items to be completed

ANNEXURE-7: APPLICATION FOR PAYMENT

Application for Payments

Site	:		Lot No	:	
Name of the Package	:		Date	:	
Name of Contractor	:		Contract No.	:	
Contract Value	:		Application Serial Number	:	

To

..... *

Dear Sir,

1. Pursuant to the above referred contract dated the undersigned hereby submit claim for payment of the sum of (Specify amount for which claim is made)

2. The above amount is on account of : (Check whichever is applicable)

- Advance payment (Schedule**)
- Interim payment as advance (Schedule**)
- Progressive payment against receipt of equipment at site (Schedule**)
- Progressive payment against erection (Schedule**)
- Transportation
- Insurance
- Price adjustment
- Extra work not specified in contract
(Ref. Contract change order No.....)
- Others (specify)
- Final payment (Schedule**)

as detailed in the attached Schedule(s) which form an integral part of this application

- 3. The payment claimed is as per item(s) No(s) of payment schedule annexed to the above mentioned Contract.
- 4. This application consist of this page, a summary of claim statement (**) and the following signed schedules:
 - 1)
 - 2)
 - 3)
 The following documents are also enclosed:
 - 1)
 - 2)
 - 3)

Signature and Seal of Contractor / Authorised Signatory

- * Application for payment will be made to "Project Manager" designated for this purpose at the time of Award of Contract.
- ** Proforma for the summary of claim will be finalized during the finalization of the Contract Agreement.

ANNEXURE-8: TAKING OVER CERTIFICATE

Taking-Over Certificate

(On the letter head of the Purchaser as per provisions of GCC 3.33)

Date:

Loan/Credit No:

Tender Notice No:

[Name of Contract]

To: [Name and address of Contractor]

Dear Sirs,

Pursuant to clause GCC 3.33 of the General Conditions of the Contract entered into between yourselves and the Purchaser dated [date], relating to the [brief description of the Works], we hereby notify you that the Functional Guarantees of the following part(s) of the Works were satisfactorily attained on the date specified below.

1. Description of the Works: [description]

2. Date of Take-Over: [date]

This letter does not relieve you of your obligation to complete the execution of the Works in accordance with the Contract nor of your obligations during the Defects Liability Period.

Very truly yours,

.....

Title

(Project Manager)

ANNEXURE-9: NO-CLAIM CERTIFICATE

No-Claim Certificate
(To be issued by the Contractor)

Name of the Package:

LoA No. /Contract No.....

Name of the Contract:

Date.....

This is to certify that we have received all payments due to us in respect of the above referred LoA/Contract and we have no claims whatsoever pending with WBDCL for this Contract.

We further confirm that we shall have no claim against this Contract in future also.

Date : (Signature).....

Place : (Name).....

(Designation).....

ANNEXURE-10A: INDEMNITY FOR EQUIPMENT

Indemnity bond to be executed by the contractor for the equipment handed over by the Purchaser for performance of its contract (Entire Equipment Consignment in one lot)

(To be executed on non-judicial stamp paper of appropriate value as per provisions of clause GCC 33.5)

INDEMNITY BOND

THIS INDEMNITY BOND is made thisday of 20 by(Contractor's Name) a Company registered under the Companies Act, 1956/Partnership firm/Proprietary concern having its registered office at (hereinafter called as '**Contractor**' or "Obligor" which expression shall include its successors and permitted assigns) in favour of **The West Bengal Power Development Corporation Limited** having its registered office at **Bidyut Unnayan Bhaban, Plot No.3C, LA-Block, Sector-III, Bidhannagar, Kolkata-700106** and its project at (hereinafter called "**WBPDCCL**" which expression shall include its successors and assigns) :

WHEREAS WBPDCCL has awarded to the Contractor a Contract forvide its Letter of Award/Contract No.....dated and its Amendment No. and Amendment No....., (applicable when amendments have been issued) (hereinafter called the "Contract") in terms of which WBPDCCL is required to hand over various Equipments to the Contractor for execution of the Contract.

And WHEREAS by virtue of Clause No..... of the said Contract, the Contractor is required to execute an Indemnity Bond in favour of WBPDCCL for the Equipments handed over to it by WBPDCCL for the purpose of performance of the Contract/Erection portion of the contract (hereinafter called the "Equipments")

AND THEREFORE, This Indemnity Bond witnesseth as follows:

1. That in consideration of various Equipments as mentioned in the Contract, valued at (Currency and amount in Figures)..... (Currency and amount in words) handed over to the Contractor for the purpose of performance of the Contract, the Contractor hereby undertakes to indemnify and shall keep WBPDCCL indemnified, for the full value of the Equipments. The Contractor hereby acknowledges actual receipt of the Equipment etc. as per dispatch title documents handed over to

the Contractor as detailed in the Schedule appended hereto. The Contractor shall hold such Equipment etc. in trust as a "Trustee" for and on behalf of WBPDCCL.

2. That the Contractor is obliged and shall remain absolutely responsible for the safe transit/protection and custody of the Equipment at WBPDCCL project site against all risks whatsoever till the Equipments are duly used/erected in accordance with the terms of the Contract and the Works duly erected and commissioned in accordance with the terms of the Contract is taken over by WBPDCCL. The Contractor undertakes to keep WBPDCCL harmless against any loss or damage that may be caused to the Equipments.
3. The Contractor undertakes that the Equipments shall be used exclusively for the performance/execution of the Contract strictly in accordance with its terms and conditions and no part of the equipment shall be utilised for any other work of purpose whatsoever. It is clearly understood by the Contractor that non-observance of the obligations under this Indemnity Bond by the Contractor shall inter-alia constitute a criminal breach of trust on the part of the Contractor for all intents and purpose including legal/penal consequences.
4. That WBPDCCL is and shall remain the exclusive Purchaser of the Equipments free from all encumbrances, charges or liens of any kind, whatsoever. The Equipments shall at all times be open to inspection and checking by the Project Manager or other employees/agents authorised by him in this regard. Further, WBPDCCL shall always be free at all times to take possession of the Equipments in whatever form the Equipments may be, if in its opinion, the equipments are likely to be endangered, misutilised or converted to uses other than those specified in the Contract, by any acts of omission or commission on the part of the Contractor or any other person or on account of any reason whatsoever and the Contractor binds himself and undertakes to comply with the directions of demand of WBPDCCL to return the Equipments without any demur or reservation.
5. That this Indemnity Bond is irrevocable. If at any time any loss or damage occurs to the Equipments or the same or any part thereof is misutilised in any manner whatsoever, then the Contractor hereby agrees that the decision of the Project Manager of WBPDCCL as to assessment of loss or damage to the Equipment shall be final and binding on the Contractor. The Contractor binds itself and undertakes to replace the lost and/or damaged Equipments at its own cost and/or shall pay the amount of loss to WBPDCCL without any demur,

reservation or protest. This is without prejudice to any other right or remedy that may be available to WBPDCCL against the Contractor under the Contract and under this Indemnity Bond.

6. NOW THE CONDITION of this Bond is that if the Contractor shall duly and punctually comply with the terms and conditions of this Bond to the satisfaction of WBPDCCL, THEN, the above Bond shall be void, but otherwise, it shall remain in full force and virtue.

IN WITNESS WHEREOF, the Contractor has hereunto set its hand through its authorised representative under the common seal of the Company, the day, month and year first above mentioned.

Schedule					
Particulars of Equipments handed over	Quantity	Particulars of Dispatch title Documents		Value of the Equipments	Signature of the Attorney in token of receipt
		RR/GR/ Bill of lading No & Date	Carrier		

For and on behalf of
.....
(Contractor's Name)

- | | | |
|---|--|---|
| 1 | 1. Signature.....
2. Name.....
3. Address..... | Signature.....
Name.....
Designation of
Authorized representative* |
| 2 | 1. Signature.....
2. Name.....
3. Address..... | (Common Seal)
(In case of company) |

*Indemnity Bond are to be executed by the authorised person and (i) in case of contracting Company under common seal of the Company or (ii) having the Power of Attorney issued under common seal of the company with authority to execute Indemnity Bond, (iii) In case of (ii), the original Power of Attorney if it is specifically for this Contract or a photostat copy of the Power of Attorney if it is General Power of Attorney and such documents should be attached to Indemnity Bond.

ANNEXURE-10B: APPLICATION FOR MATERIAL GATE PASS

(On Company letter head of Contractor)

Application for Material Gate Pass

To,

(Project In-Charge)
WBPDCCL, SgTPP Site

Ref. No.

i. LOA no. _____ Dated: _____

ii. MDCC No. _____ Dated: _____

iii. Invoice Details

No. _____ Dated: _____

Quantity _____ Cost: _____
Dated: _____

Subject: *Name of the work*

Dear Sir,

1. Pursuant to the above referred LOA/contract, the undersigned hereby submit request for gate pass for the above referred invoice materials.
2. As per the clause no. 3.39 of the GCC of the contract document, name of the contractor is fully responsible for care of the materials after the entry of the materials in side WBPDCCL premises until handover of the plant.
3. Name of the contractor is fully responsible for storage and safety security of the materials.
4. If at any time any loss or damage occurs to the Equipments or the same or any part thereof is misutilised in any manner whatsoever, then name of the contractor hereby agrees that WBPDCCL will not be responsible in any way

Very truly yours,

(Project Manager)

ANNEXURE-11: AUTHORISATION LETTER

Authorization letter
(On the letter head of Purchaser)

Ref No:
Date:

To,

M/s (Contractor's Name).....

Ref: Contract NoDated
for awarded by WBPDC

Dear Sirs,

Kindly refer to Contract No..... Dated for..... (Contract Name).You are hereby authorised on behalf of WBPDC having its registered office at to take physical delivery of materials/equipments covered under dispatch Document/ Consignment Note no.....[mention LR/RR No].....dated and as detailed in the enclosed Schedule for the sole purpose of successful performance of the aforesaid contract and for no other purposes, whatsoever.

(Signature of Project Manager)

Designation:

Date:

ENCL: As above

ANNEXURE-12: MATERIAL RECEIPT CERTIFICATE

Material Receipt Certificate

Name of the Work:
LoA No. /Contract No.....
Name of the Contractor:

Material Receipt Certificate No. _____ Date: _____

BS Sl. No.	MD CC Ref. No.	LR No. & Dt	Gate Entry No. & Receipt dt	U O M	Qty as per Invoice	Material Description	Quantity				Remarks			
							U O M	As per BS	Claim up to previous MRC			Claim in this MRC	Cuml. Received	Balance
									M RC No	Qty				

Note: Above Materials received and verified and handed over the above to name of the contractor for their safe custody, erection and commissioning.

Contractor _____

WBPDC

BOQ for Price Schedule

Tender Inviting Authority: GM(M&C)

Name of Work: Design & Engineering, Manufacture / Procurement, Supply, Installation, Testing and Commissioning of 10 MW Phase-II Grid connected Floating Solar Photovoltaic Power Plants on Raw Water Pond No.1, 2, & 4 in Sagardighi Thermal Power Project (SgTPP), Murshidabad, West Bengal, India in turnkey basis including warrantee obligation with 05 (Five) years comprehensive Operation and Maintenance.

Contract No: WBPDC/CORP/NIT/E1317/19-20 Dtd:-12/03/2020

Name of the Bidder/ Bidding Firm / Company :										
PRICE SCHEDULE										
(This BOQ template must not be modified/replaced by the bidder and the same should be uploaded after filling the relevant columns, else the bidder is liable to be rejected for this tender. Bidders are allowed to enter the Bidder Name and Values only) (RATES ARE TO GIVEN IN RUPEES (INR) ONLY)										
NUMBER #	TEXT #	NUMBER #	TEXT #	NUMBER #	NUMBER	NUMBER	NUMBER	NUMBER #	NUMBER #	TEXT #
Sl. No.	Item Description	Quantity	Units	Amount to be entered by the bidder in INR without TAX	Goods & Service Taxes in INR	Total Custom Duty(Sl. No.1)/BOCW(Sl. No.2) in INR	Total Tax & Duty in INR	TOTAL AMOUNT Without Taxes	TOTAL AMOUNT With Taxes	TOTAL AMOUNT In Words
1	2	4	5	13	14	15	16	53	54	55
1	Supply Schedule									
1.01	Cost in Rs. for 10 MW Floating Solar PV plant for Supply of Materilas as per Clause No: 1.29 of the NIT.	1.000	Nos				0.0000	0.000	0.000	INR Zero Only
1.02	Total Transport, Loading, Unloading, Insurance charge.	1.000	Nos				0.0000	0.000	0.000	INR Zero Only
2	Erection & Commissioning Schedule									
2.01	Cost in Rs. for 10 MW Floating Solar PV plant for Installation Service as per Clause No: 1.29 of the NIT	1.000	Nos				0.0000	0.000	0.000	INR Zero Only
2.02	Cost in Rs. for 10 MW Floating Solar PV plant for Testing and Commissioning as per Clause No: 1.29 of the NIT	1.000	Nos				0.0000	0.000	0.000	INR Zero Only
2.03	Cost in Rs. of Material used for Erection & Commissioning for 10 MW Floating Solar PV plant as per Clause No: 1.29 of NIT	1.000	Nos				0.0000	0.000	0.000	INR Zero Only
Total in Figures								0.000	0.000	INR Zero Only
Quoted Rate in Words		INR Zero Only								

TENDER LAYOUT DRAWING

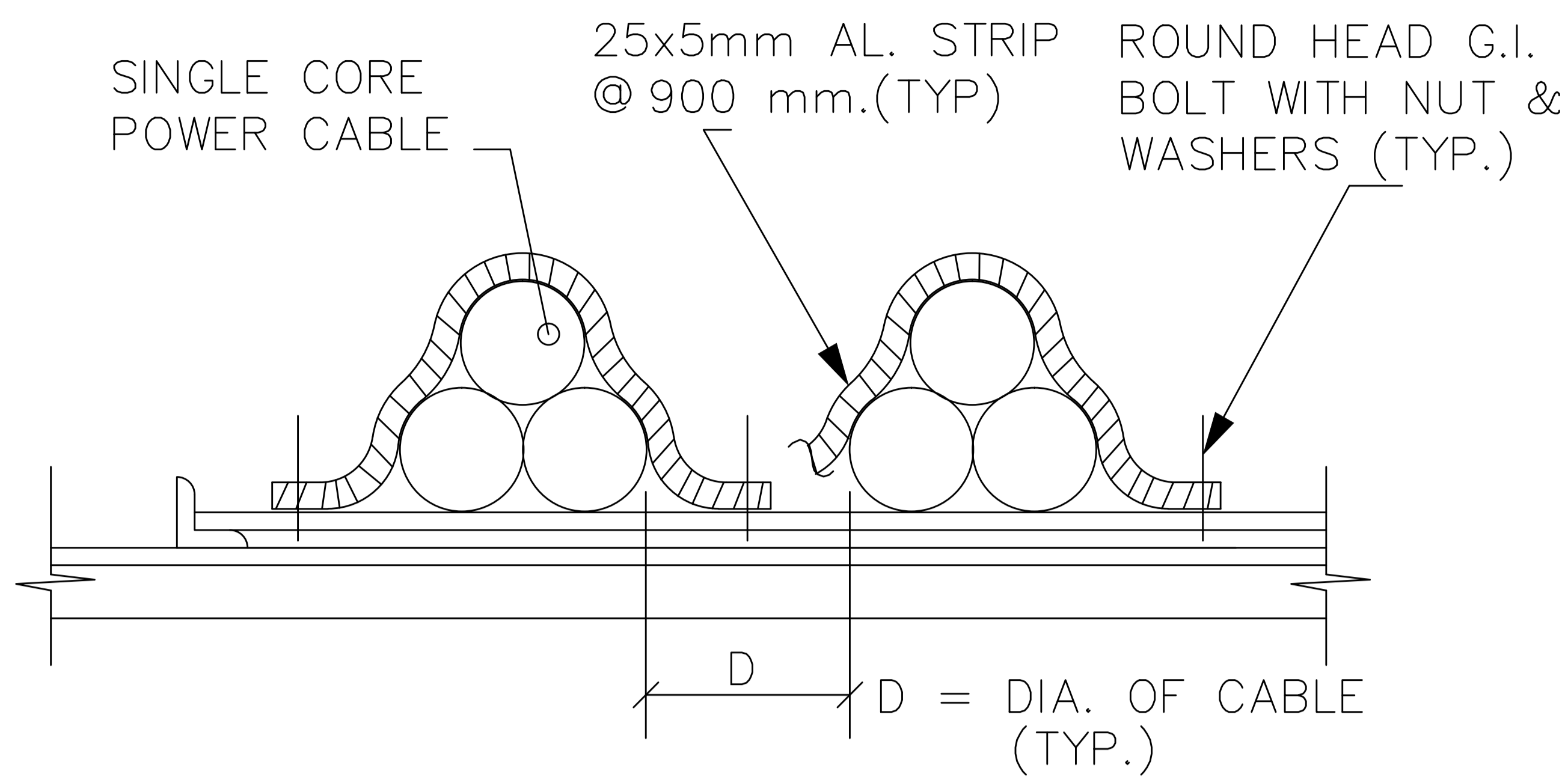

CABLE CLAMPS IN TREFOIL FORMATION FOR SINGLE CORE POWER CABLES

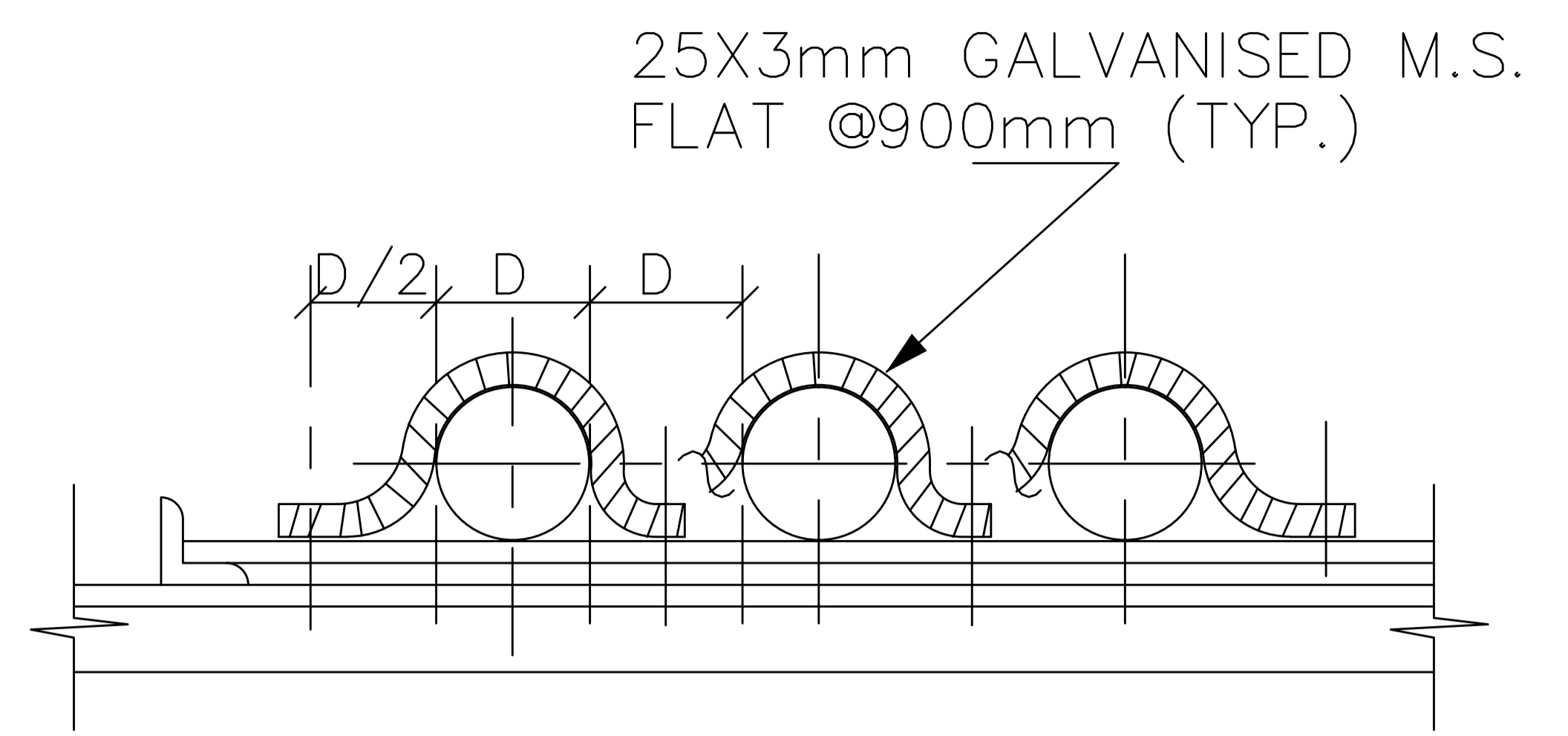

CABLE CLAMPS FOR MULTICORE POWER CABLES (NOT TOUCHING EACHOTHER)

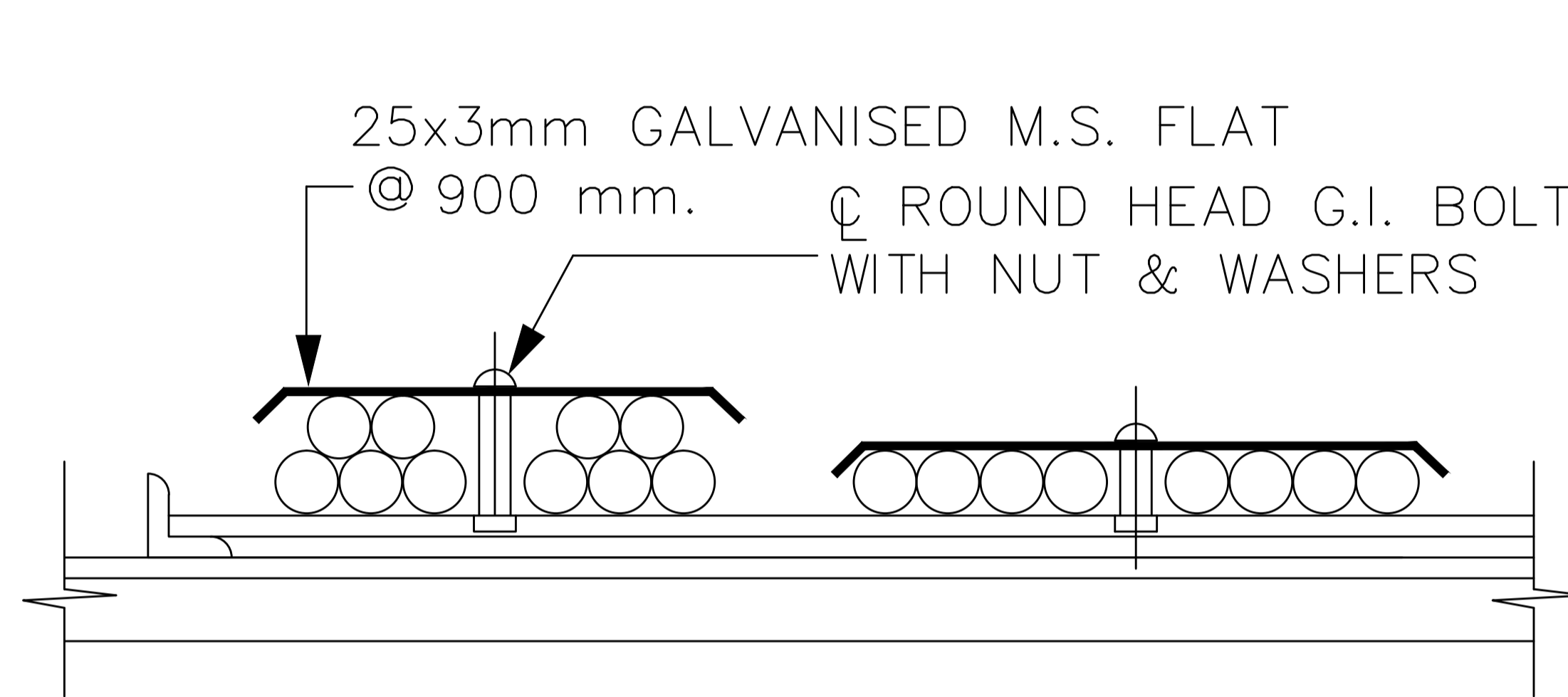

CLAMPING ARRANGEMENT OF CONTROL CABLES

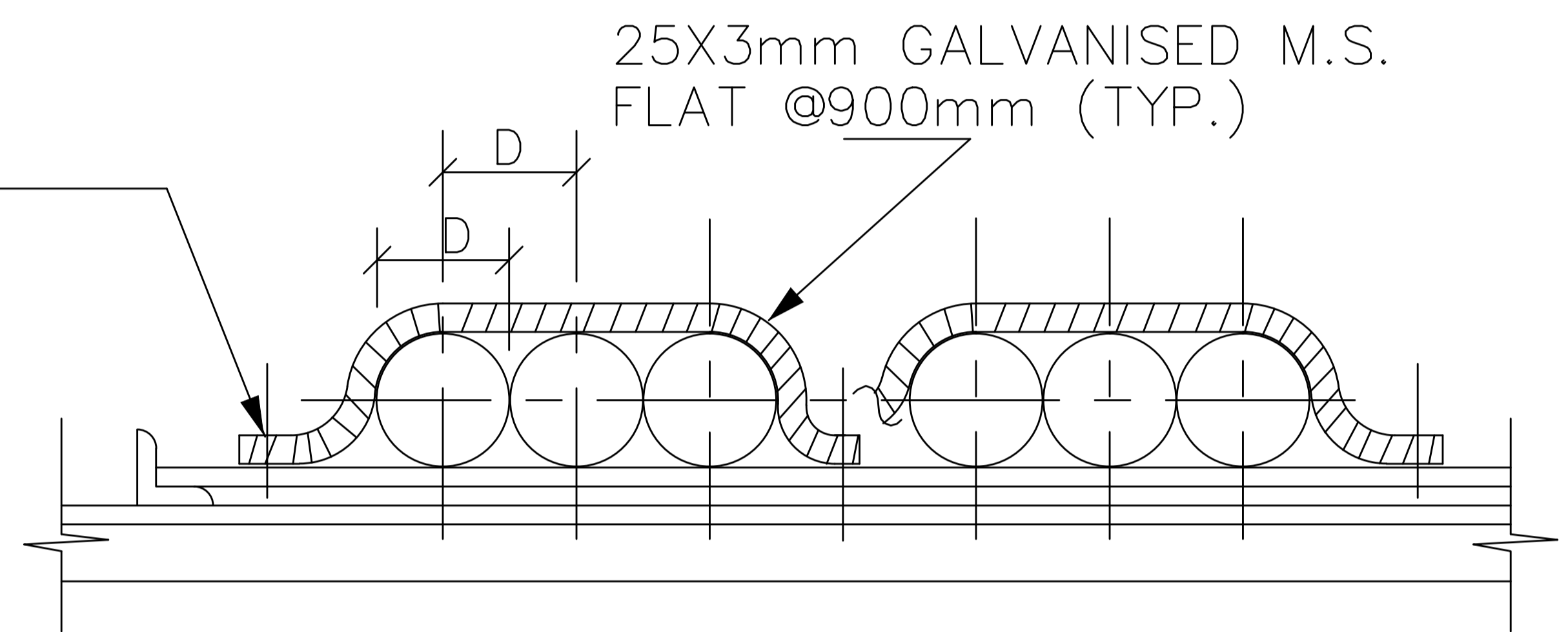

CABLE CLAMPS FOR MULTICORE POWER CABLES (TOUCHING EACHOTHER)

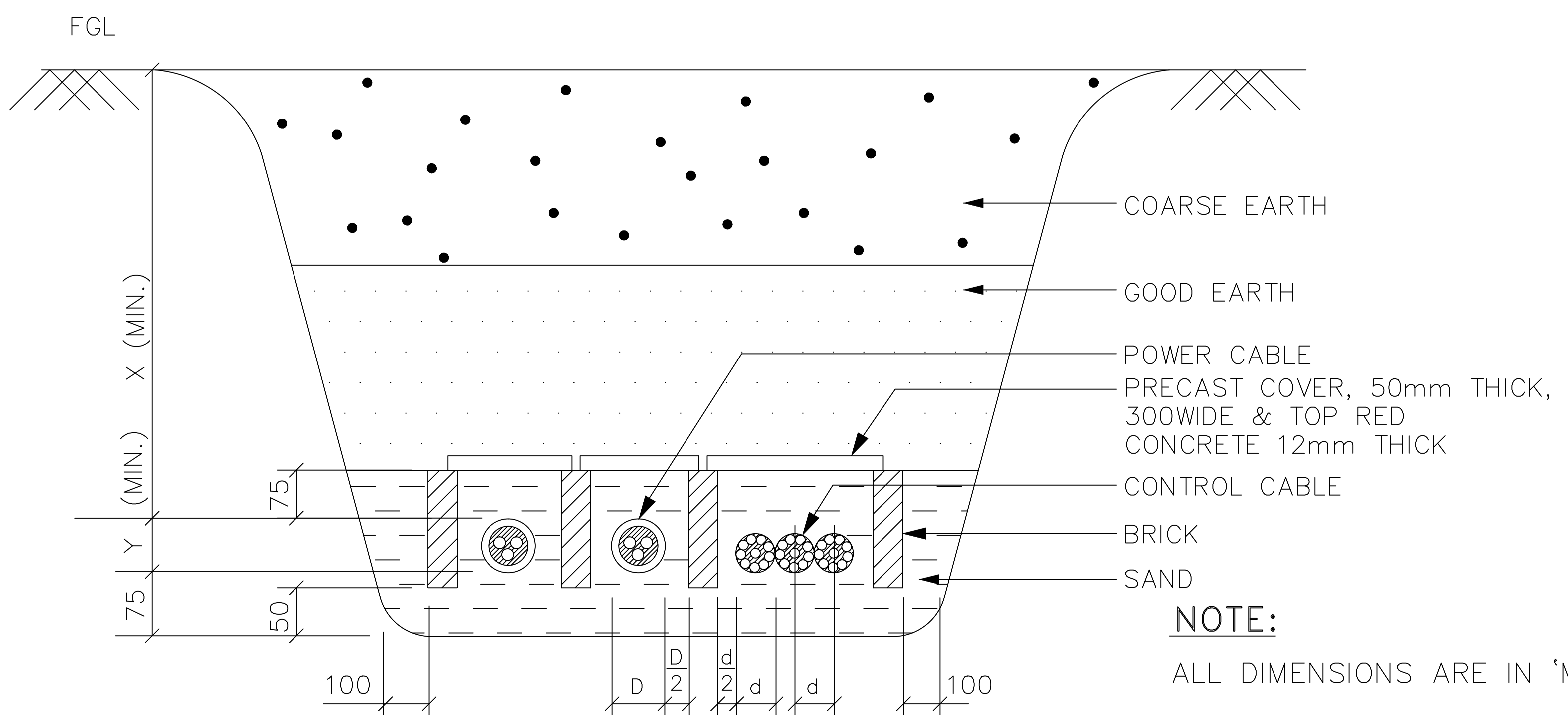

BURIED CABLE LAYING DETAILS

NOTE:

ALL DIMENSIONS ARE IN 'MM'.
X DEPTH FROM FGL AS PER IS
Y DIAMETER OF CABLE

FOR TENDER PURPOSE ONLY

					CABLING NOTES & DETAILS		THE WEST BENGAL POWER DEVELOPMENT CORPORATION LTD.	
					WEST BENGAL POWER DEVELOPMENT CORP. LTD.		SCALE : NONE	
CKP	CKP	SC	0	27.12.19	SAGARDIGHI THERMAL POWER PROJECT		DWG. NO. SG-FSLP-DWG-E-002	
APPVD.	REVWD.	CHKD.	REV.	DATE	Floating Solar Plant on Raw Water Pond # 1, 2 & 4.		REV. 0	

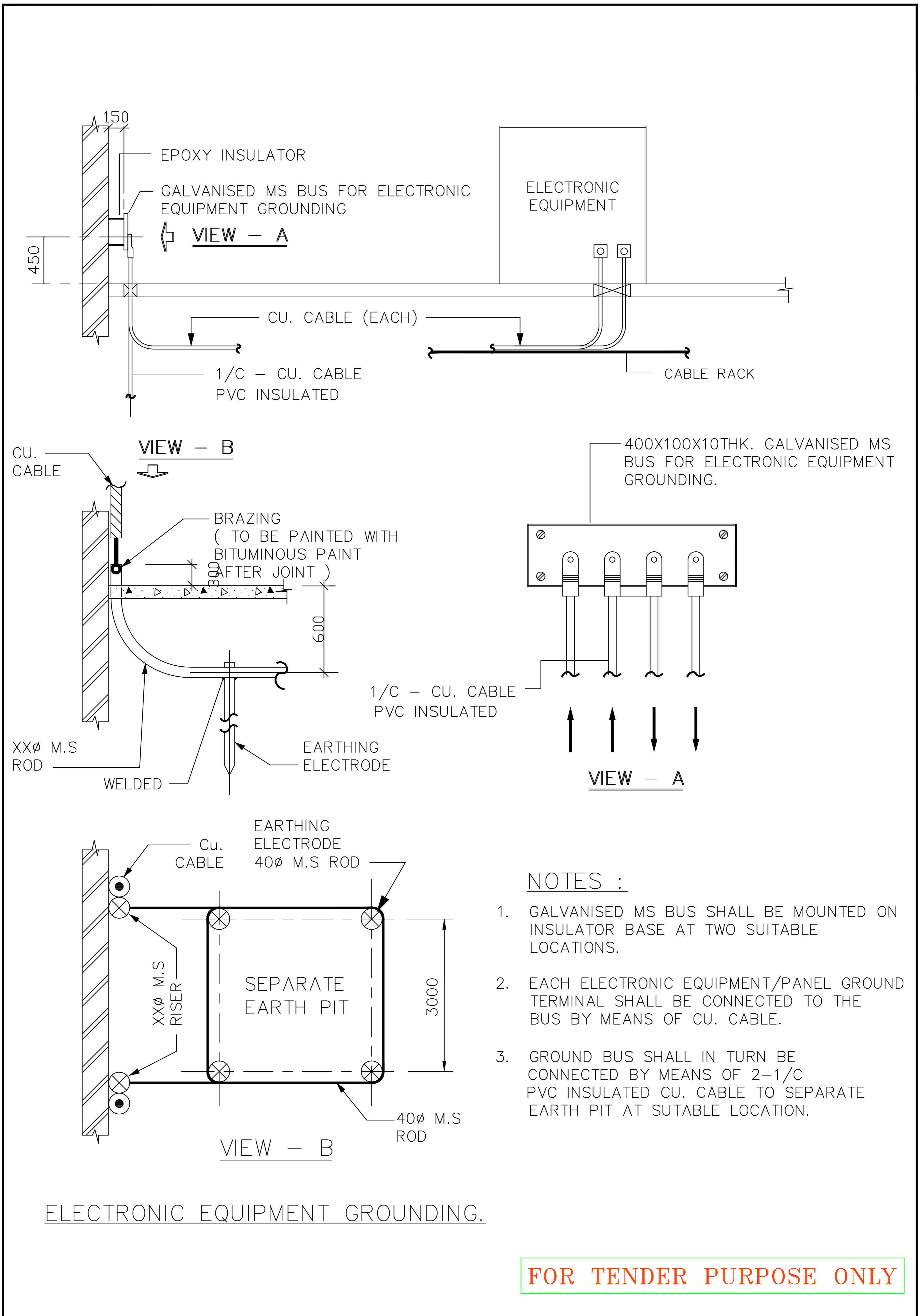

					GROUNDING NOTES & DETAILS		THE WEST BENGAL POWER DEVELOPMENT CORPORATION LTD.	
					WEST BENGAL POWER DEVELOPMENT CORP. LTD.		JOB NO. SGFLSP-01	SCALE : NONE
CKP	SC	SC	0	19.02.20	SAGARDIGHI THERMAL POWER PROJECT		DWG. NO. SG-FLSP-DWG-E-003	REV.
APPVD.	REVWD.	CHKD.	REV.	DATE	Floating Solar Plant on Raw Water Pond # 1, 2 & 4.		SHT. 1 OF 1	0